

STYLE:

smart



fontanot®  
scale di ogni tempo





PH 2



16 mm (5/8")

450 ÷ 500 mm  
(17 - 19 1/16") ÷ (19 - 21 1/16")  
60 ÷ 200 Nm



10 mm (25/64")  
13 mm (33/64")  
17 mm (43/64")



2 mm (5/64")  
2,5 mm (3/32")  
3 mm (1/8")  
5 mm (13/64")  
6 mm (15/64")



13 mm (33/64")  
16 mm (5/8")  
17 mm (43/64")  
19 mm (3/4")  
22 mm (55/64")



Ø 8 x 300 mm  
(D 5/16" x 11 - 13/16")  
Ø 12 x 120 mm  
(D 15/32" x 4 - 23/32")  
Ø 14 x 170 mm  
(D 35/64" x 6 - 11/16")  
Ø 18 x 120 mm  
(D 45/64" x 4 - 23/32")



Ø 2,5 mm (3/32")  
Ø 3 mm (1/8")



contanot

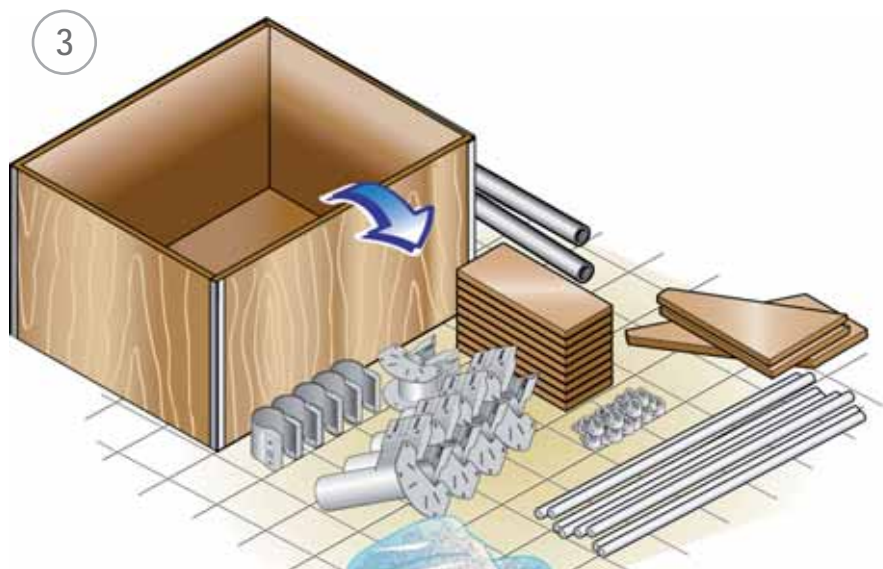
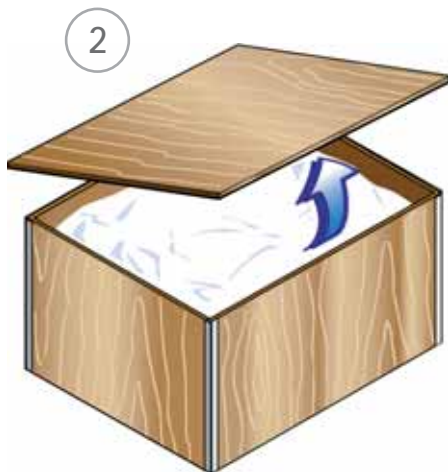
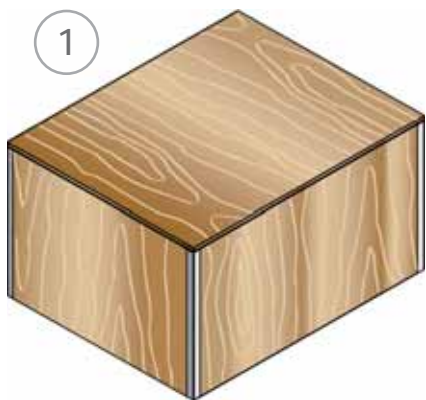

	11	12	13	14	15	16
"I"	2	2	2	2	2	2
"L"	2	2	4	4	4	4
"U"	2	2	4	4	4	4

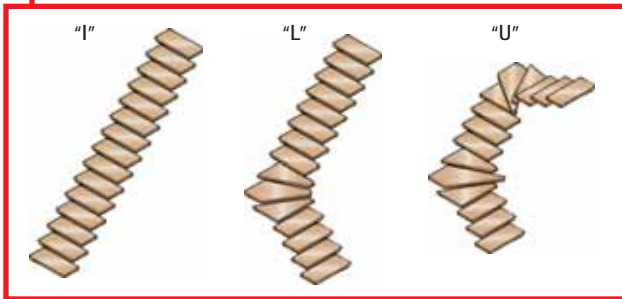
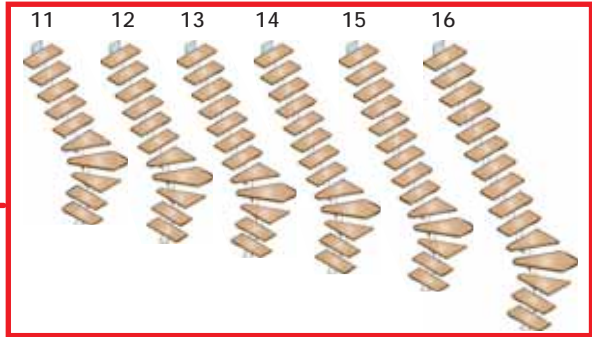

A23



	11	12	13	14	15	16
"I"	4	4	5	5	5	5
"L"	3	3	4	4	4	4
"U"	3	3	4	4	4	4

A37



	11	12	13	14	15	16
"I"	2	2	2	2	2	2
"L"	4	4	4	4	4	4
"U"	6	6	6	6	6	6

B02



	11	12	13	14	15	16
"I"	35	38	41	44	47	50
"L"	28	31	34	37	40	43
"U"	22	25	28	31	34	37

**B12**

∅ 8 mm  
(D<sup>5/16"</sup>)

	11	12	13	14	15	16
"I"	10	10	10	10	10	10
"L"	10	10	10	10	10	10
"U"	10	10	10	10	10	10

**B13**

M8 mm  
(M<sup>5/16"</sup>)

	11	12	13	14	15	16
"I"	2	2	2	2	2	2
"L"	2	2	2	2	2	2
"U"	2	2	2	2	2	2

**B20**

	11	12	13	14	15	16
"I"	3	3	3	3	3	3
"L"	3	3	3	3	3	3
"U"	3	3	3	3	3	3

**B33**

M14 x 43 mm  
(M<sup>35/64"</sup> x 1-<sup>11/16"</sup>)

	11	12	13	14	15	16
"I"	4	4	5	5	5	5
"L"	3	3	4	4	4	4
"U"	3	3	4	4	4	4

**B82**

	11	12	13	14	15	16
"I"	20	22	24	26	28	30
"L"	15	17	19	21	23	25
"U"	10	12	14	16	18	20

**B95**

	11	12	13	14	15	16
"I"	4	4	4	4	4	4
"L"	4	4	4	4	4	4
"U"	4	4	4	4	4	4

**BB5**

M4,5 x 40 mm  
(M<sup>11/64"</sup> x 1-<sup>37/64"</sup>)

	11	12	13	14	15	16
"I"	93	102	111	120	129	138
"L"	72	81	90	99	108	117
"U"	54	63	72	81	90	99

**BS2**

	11	12	13	14	15	16
"I"	18	20	22	24	26	28
"L"	18	20	22	24	26	28
"U"	18	20	22	24	26	28

**BS4**

	11	12	13	14	15	16
"I"	0	0	0	0	0	0
"L"	6	6	6	6	6	6
"U"	12	12	12	12	12	12

**BS6**

	11	12	13	14	15	16
"I"	36	40	44	48	52	56
"L"	36	40	44	48	52	56
"U"	36	40	44	48	52	56

**C03**

	11	12	13	14	15	16
"I"	20	22	24	26	28	30
"L"	15	17	19	21	23	25
"U"	10	12	14	16	18	20

**C13**

	11	12	13	14	15	16
"I"	31	34	37	41	44	47
"L"	24	27	30	33	36	39
"U"	18	21	24	27	30	33

**C35**

	11	12	13	14	15	16
"I"	1	1	1	1	1	1
"L"	1	1	1	1	1	1
"U"	1	1	1	1	1	1

**C47**

	11	12	13	14	15	16
"I"	3	3	3	3	3	3
"L"	3	3	3	3	3	3
"U"	3	3	3	3	3	3

**C48**

	11	12	13	14	15	16
"I"	2	2	2	2	2	2
"L"	2	2	2	2	2	2
"U"	2	2	2	2	2	2

C49



M6 mm  
(M<sup>15/64"</sup>)

	11	12	13	14	15	16
"I"	2	2	2	2	2	2
"L"	4	4	4	4	4	4
"U"	6	6	6	6	6	6

C50



M6 x 25 mm  
(M<sup>15/64"</sup> x 6<sup>3/64"</sup>)

	11	12	13	14	15	16
"I"	2	2	2	2	2	2
"L"	4	4	4	4	4	4
"U"	6	6	6	6	6	6

C53



	11	12	13	14	15	16
"I"	40	44	48	52	56	60
"L"	40	44	48	52	56	60
"U"	40	44	48	52	56	60

C54



	11	12	13	14	15	16
"I"	2	2	2	2	2	2
"L"	2	2	2	2	2	2
"U"	2	2	2	2	2	2

C57



	11	12	13	14	15	16
"I"	4	4	4	4	4	4
"L"	4	4	4	4	4	4
"U"	4	4	4	4	4	4

C58



Ø 6,4 x 40 mm  
(Ø 1/4" x 1-<sup>37/64"</sup>)

	11	12	13	14	15	16
"I"	8	8	8	8	8	8
"L"	8	8	8	8	8	8
"U"	8	8	8	8	8	8

C62



	11	12	13	14	15	16
"I"	2	2	2	2	2	2
"L"	2	2	2	2	2	2
"U"	2	2	2	2	2	2

C63



	11	12	13	14	15	16
"I"	20	22	24	26	28	30
"L"	15	17	19	21	23	25
"U"	10	12	14	16	18	20

C64



Ø 3,5 x 38 mm  
(Ø 9/64" x 1-<sup>1/2"</sup>)

	11	12	13	14	15	16
"I"	40	46	50	54	58	62
"L"	34	38	42	46	50	54
"U"	26	30	34	38	40	42

C65



M4 mm  
(M<sup>5/32"</sup>)

	11	12	13	14	15	16
"I"	20	22	24	26	28	30
"L"	15	17	19	21	23	25
"U"	10	12	14	16	18	20

C66



M4 x 14 mm  
(M<sup>5/32"</sup> x 3<sup>5/64"</sup>)

	11	12	13	14	15	16
"I"	20	22	24	26	28	30
"L"	15	17	19	21	23	25
"U"	10	12	14	16	18	20

C81



	11	12	13	14	15	16
"I"	2	2	2	2	2	2
"L"	2	2	2	2	2	2
"U"	2	2	2	2	2	2

C83



	11	12	13	14	15	16
"I"	2	2	2	2	2	2
"L"	2	2	2	2	2	2
"U"	2	2	2	2	2	2

D27



	11	12	13	14	15	16
"I"	9	10	11	12	13	14
"L"	9	10	11	12	13	14
"U"	9	10	11	12	13	14

D28



	11	12	13	14	15	16
"I"	9	10	11	12	13	14
"L"	9	10	11	12	13	14
"U"	9	10	11	12	13	14

D29



	11	12	13	14	15	16
"I"	9	10	11	12	13	14
"L"	9	10	11	12	13	14
"U"	9	10	11	12	13	14

D31



	11	12	13	14	15	16
"I"	1	1	1	1	1	1
"L"	1	1	1	1	1	1
"U"	1	1	1	1	1	1

D34



	11	12	13	14	15	16
"I"	1	1	1	1	1	1
"L"	1	1	1	1	1	1
"U"	1	1	1	1	1	1

D43



	11	12	13	14	15	16
"I"	2	2	2	2	2	2
"L"	2	2	2	2	2	2
"U"	2	2	2	2	2	2

D72



	11	12	13	14	15	16
"I"	4	4	5	5	5	5
"L"	3	3	4	4	4	4
"U"	3	3	4	4	4	4

D80



	11	12	13	14	15	16
"I"	18	20	22	24	26	28
"L"	18	20	22	24	26	28
"U"	18	20	22	24	26	28

F08



	11	12	13	14	15	16
"I"	4	4	4	4	4	4
"L"	8	8	8	8	8	8
"U"	12	12	12	12	12	12

F09



	11	12	13	14	15	16
"I"	2	2	2	2	2	2
"L"	2	2	2	2	2	2
"U"	2	2	2	2	2	2

F12



	11	12	13	14	15	16
"I"	2	2	2	2	2	2
"L"	2	2	2	2	2	2
"U"	2	2	2	2	2	2

F34



	11	12	13	14	15	16
"I"	2	2	2	2	2	2
"L"	2	2	2	2	2	2
"U"	2	2	2	2	2	2

F65



	11	12	13	14	15	16
"I"	29	32	35	38	41	44
"L"	22	25	28	31	35	38
"U"	16	22	25	28	31	19

F66



	11	12	13	14	15	16
"I"	2	2	2	2	2	2
"L"	2	2	2	2	2	2
"U"	2	2	2	2	2	2

G08



	11	12	13	14	15	16
"I"	1	1	1	1	1	1
"L"	1	1	1	1	1	1
"U"	1	1	1	1	1	1

L25

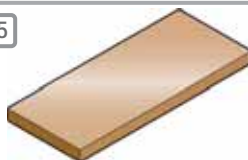

	11	12	13	14	15	16
"I"	10	11	12	13	14	15
"L"	7	8	9	10	11	12
"U"	4	5	6	7	8	9

L26



	11	12	13	14	15	16
"I"	0	0	0	0	0	0
"L"	1	1	1	1	1	1
"U"	2	2	2	2	2	2



L27



	11	12	13	14	15	16
"I"	0	0	0	0	0	0
"L"	1	1	1	1	1	1
"U"	2	2	2	2	2	2

L28



	11	12	13	14	15	16
"I"	0	0	0	0	0	0
"L"	1	1	1	1	1	1
"U"	2	2	2	2	2	2

N20



	11	12	13	14	15	16
"I"	1	1	1	1	1	1
"L"	1	1	1	1	1	1
"U"	1	1	1	1	1	1

N25



	11	12	13	14	15	16
"I"	1	1	1	1	1	1
"L"	1	1	1	1	1	1
"U"	1	1	1	1	1	1

N68



	11	12	13	14	15	16
"I"	1	1	1	1	1	1
"L"	1	1	1	1	1	1
"U"	1	1	1	1	1	1

N69



	11	12	13	14	15	16
"I"	1	1	1	1	1	1
"L"	1	1	1	1	1	1
"U"	1	1	1	1	1	1

N70



	11	12	13	14	15	16
"I"	7	8	9	10	11	12
"L"	7	8	9	10	11	12
"U"	7	8	9	10	11	12

N71



	11	12	13	14	15	16
"I"	9	10	11	12	13	14
"L"	9	10	11	12	13	14
"U"	9	10	11	12	13	14

X01



	11	12	13	14	15	16
"I"	1	1	1	1	1	1
"L"	1	1	1	1	1	1
"U"	1	1	1	1	1	1



**IT) ATTENZIONE!**

**Leggere e seguire scrupolosamente queste istruzioni e tenere per future consultazioni.**

Eseguire l'installazione "a regola d'arte", utilizzando attrezzi idonei; seguire scrupolosamente le istruzioni di montaggio. Informarsi prima dell'installazione, sui regolamenti locali e nazionali da rispettare, in funzione della destinazione d'uso (privato principale, secondario, uffici, negozi,...).

**FR) ATTENTION !**

**Lire et respecter scrupuleusement les présentes instructions ; les conserver pour toute autre consultation.**

Effectuer l'installation dans les règles de l'art en utilisant des outils appropriés ; suivre scrupuleusement les instructions de montage. Pour réaliser un montage conforme aux normes en vigueur, il faut s'informer avant l'installation quant aux réglementations locales et nationales à respecter, en fonction du domaine d'utilisation (résidence privée principale, secondaire, bureaux, magasins,...).

**EN) WARNING!**

**Carefully read and strictly follow these instruction and keep them for future consultation.**

Carry out the installation in a "workmanlike" manner, strictly following the installation instructions and using suitable tools. Always consult your local building department for code requirements that must be respected depending on its destination of use (private, secondary, public...).

**DE) ACHTUNG!**

**Lesen sie diese Anleitung sorgfältig durch und heben sie sie für spätere Zwecke auf.**

Die Montage muss fachgerecht, unter Zuhilfenahme geeigneter Hilfsmittel und unter strikter Einhaltung der Montageanleitung ausgeführt werden. Damit die Montage normgerecht erfolgen kann, muss man zuvor Informationen zur Aufstellung und zu den lokal und national geltenden Vorschriften je nach Bestimmungszweck (privat, Haupt- oder Nebeneinrichtung, Büros, Geschäfte, ...) einholen.

**ES) ¡ATENCIÓN!**

**Leer y seguir estrictamente estas instrucciones y conservarlas para consultas futuras.**

Realizar la instalación "según las reglas del arte", utilizando herramientas adecuadas; seguir estrictamente las instrucciones de montaje. Informarse antes de la instalación sobre los reglamentos locales y nacionales a respetar, en función del destino de uso (privado principal, secundario, oficinas, tiendas,...).



#### NL) OPGELET!

**Verricht de installatie volgens de technische normen met behulp van geschikte gereedschappen.**

Volg nauwgezet de montage handleiding. Ga voor de installatie na of er plaatselijk of nationaal regelgeving van toepassing is voor het bedoelde gebruik (privé, kantoor, winkels, enz).

#### SV) OBSERVERA!

**Läs och följ noggrant dessa anvisningar och spara dem för framtida konsultation.**

Utför installationen på ett yrkesmannamässigt sätt med lämpliga verktyg. Följ monteringsinstruktionerna i detalj. Informera dig före installationen om lokala och nationella bestämmelser som ska respekteras, beroende på avsett användningsområde (privat, offentlig, kontor, butiker o.s.v.).

#### DA) ADVARSEL!

**Læs og overhold nøje disse anvisninger og opbevar dem til efterfølgende henvisninger.**

Installationen skal udføres i overensstemmelse med bedste praksis, ved brug af egnede redskaber; følg omhyggeligt monteringsinstruktionerne. Hent oplysninger før installationen angående de lokale og nationale bestemmelser, der skal overholdes afhængigt af den påtænkte anvendelse (privat hovedbrug, privat sekundær brug, kontorer, butikker,...).

#### NO) ADVARSEL!

**Les og følg bruksanvisningen nøye og oppbevar den for senere bruk.**

Produktet må installeres "etter alle kunstens regler" og med passende verktøy. Følg monteringsbeskrivelsen nøye. Informer deg om eventuelle lokale og nasjonale forskrifter som gjelder for ditt spesielle bruksområde (primær eller sekundær privat bruk, kontorer, forretninger osv.) før du installerer produktet.

#### FI) VAROITUS!

**Lue ja noudata huolellisesti näitä ohjeita ja säilytä ne tulevaa tarvetta varten.**

Suorita asennus kunnolla käyttäen asianmukaisia välineitä; noudata huolellisesti asennusohjeita. Tutustu ennen asennusta voimassa oleviin paikallisiin ja kansallisiin määräyksiin, käyttökohteen mukaan (yksityinen pääasiallinen, toissijainen, toimisto, kaupat,...).

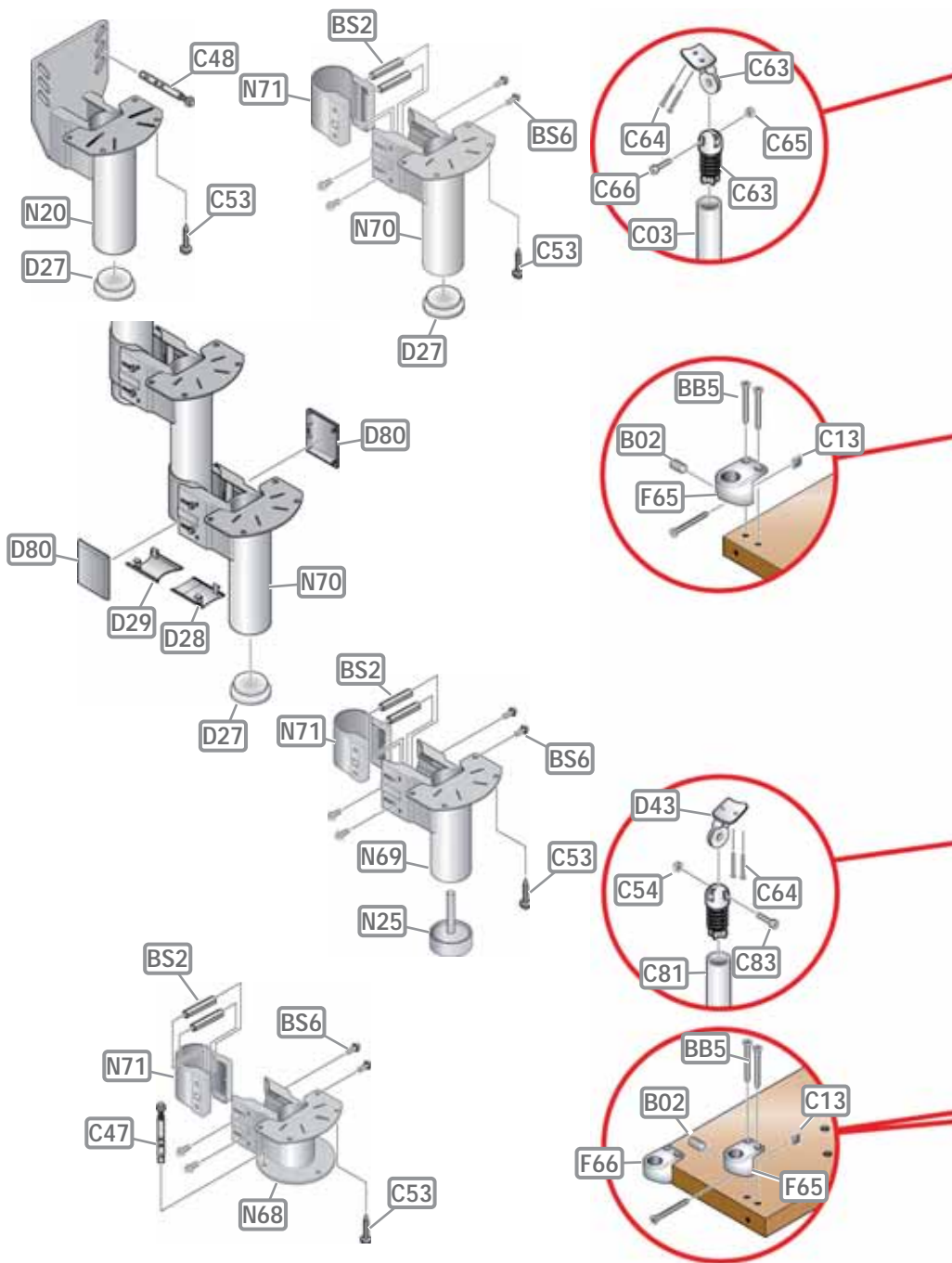

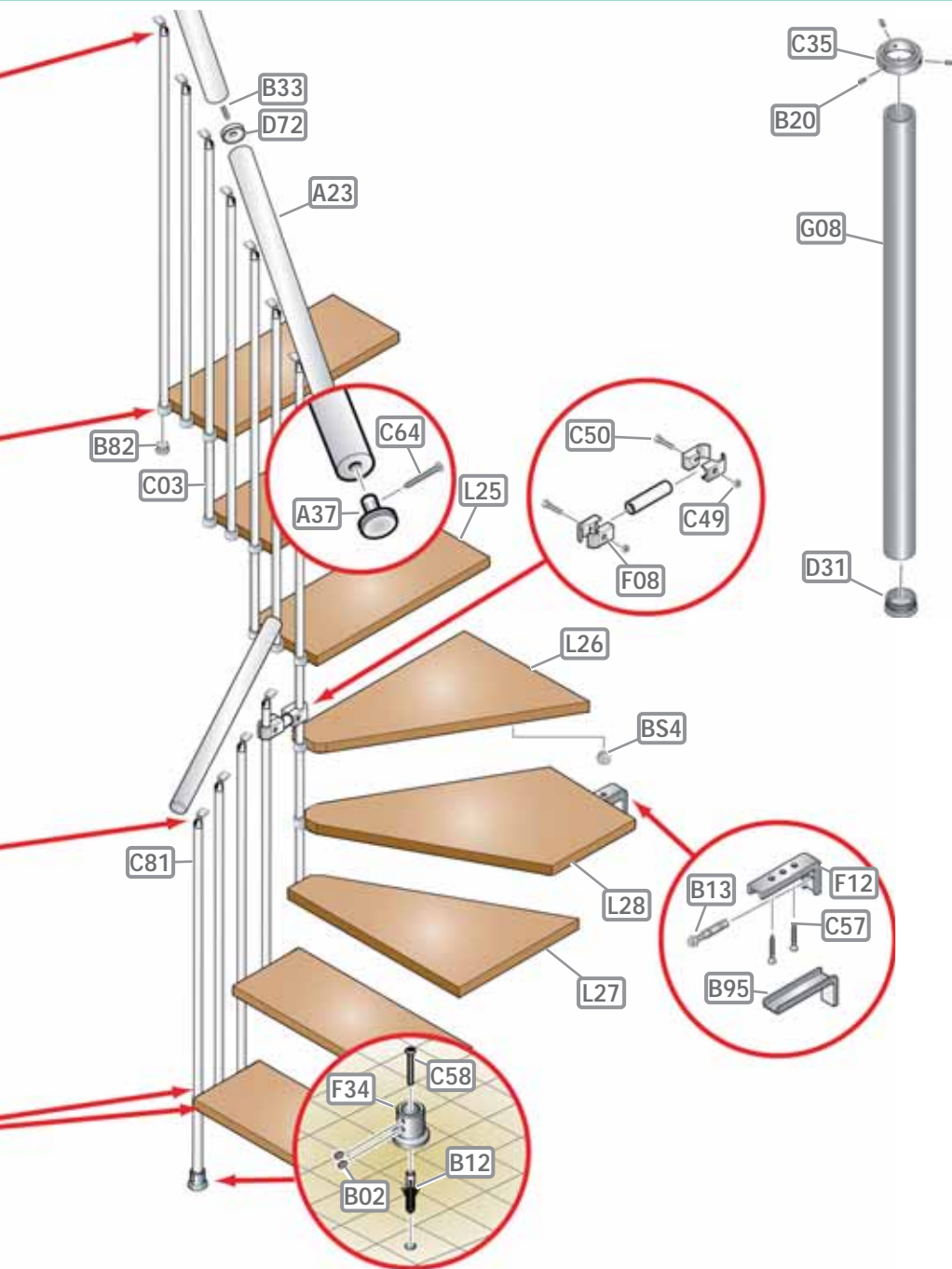

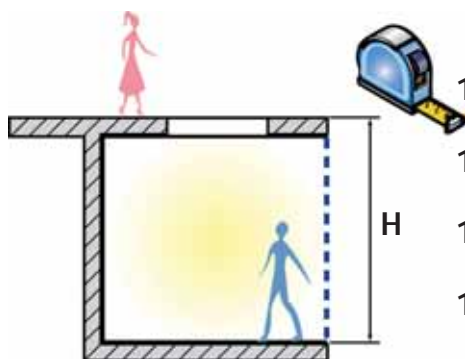
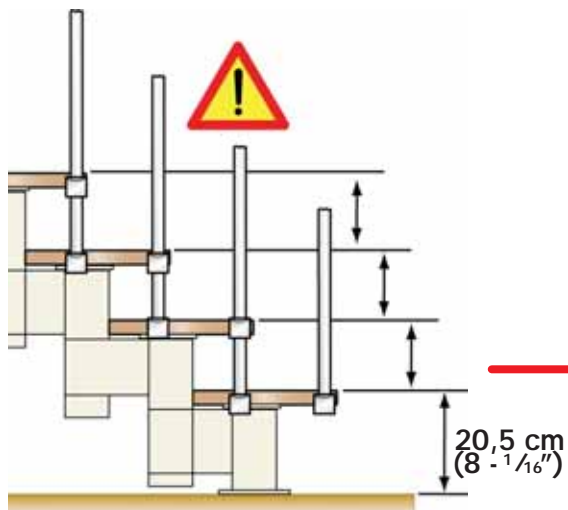

- 11 (N) →  $H = 191 \div 255 \text{ cm}$   
 $H = (75 - 3/16" \div 100 - 3/8")$
- 12 (N) →  $H = 208 \div 279 \text{ cm}$   
 $H = (81 - 7/8" \div 109 - 13/16")$
- 13 (N) →  $H = 225 \div 303 \text{ cm}$   
 $H = (88 - 9/16" \div 119 - 5/16")$
- 14 (N) →  $H = 242 \div 327 \text{ cm}$   
 $H = (95 - 1/4" \div 128 - 3/4")$
- 15 (N) →  $H = 258 \div 349 \text{ cm}$   
 $H = (101 - 9/16" \div 137 - 3/8")$
- 16 (N) →  $H = 275 \div 373 \text{ cm}$   
 $H = (108 - 1/4" \div 146 - 7/8")$

11 (N)

12 (N)

13 (N)

14 (N)

15 (N)

16 (N)

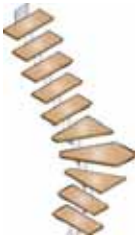

$$A = H \cdot 20,5 \text{ cm} / N - 1$$

$$A = H \cdot (8 \cdot \frac{1}{16}'' ) / N - 1$$

$$(A = 17 \div 20,5 \text{ cm})$$

$$(A = 6 \cdot \frac{11}{16}'' \div 8 \cdot \frac{1}{16}'' )$$

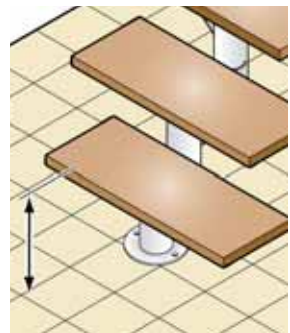
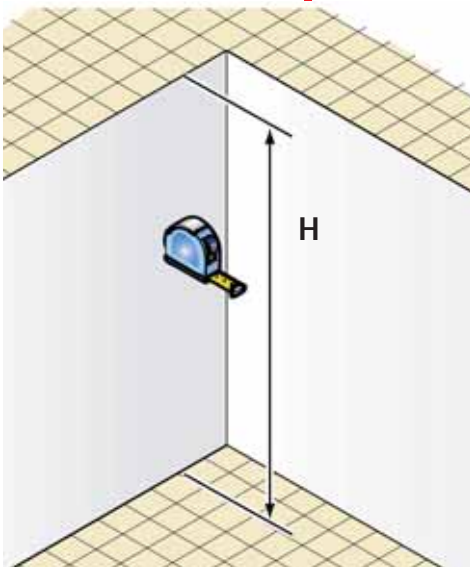

4

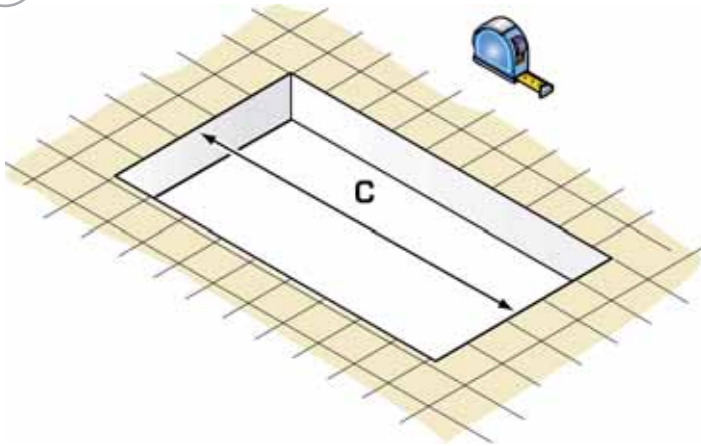



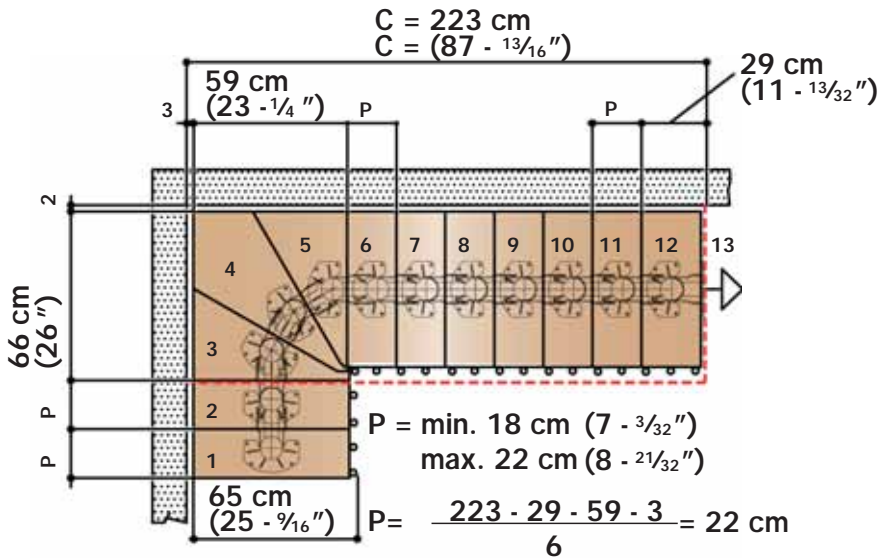

$$P = \frac{(87 - ^{13}/_{16}'' ) - (11 - ^{13}/_{32}'' ) - (23 - ^{1}/_{4}'' ) - (1 - ^{3}/_{16}'' )}{(2 - ^{3}/_{8}'' )} = (8 - ^{21}/_{32}'' )$$

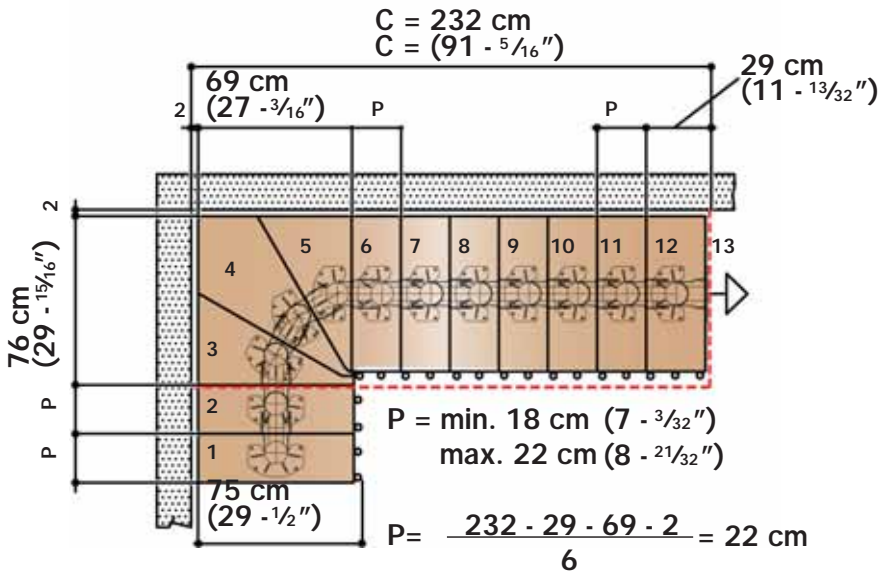

$$P = \frac{(91 - ^{5}/_{16}'' ) - (11 - ^{13}/_{32}'' ) - (27 - ^{3}/_{16}'' ) - (2 - ^{5}/_{32}'' )}{(2 - ^{3}/_{8}'' )} = (8 - ^{21}/_{32}'' )$$

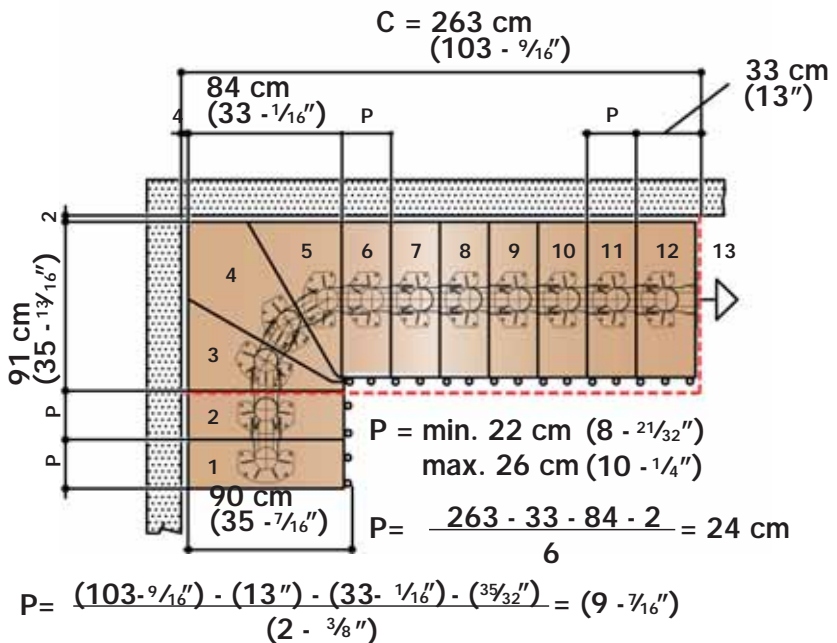
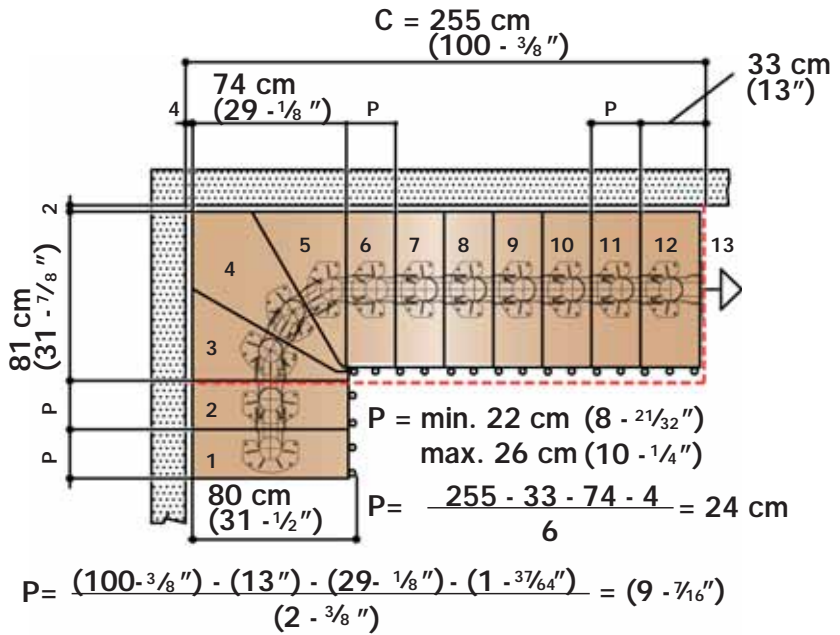

	cm	inch	cm	inch
L	65	(25 - 9/16)	75	(29 - 1/2)
G	60	(23 - 5/8)	70	(27 - 9/16)
P	18	(7 - 3/32)	18	(7 - 3/32)
	19	(7 - 15/32)	19	(7 - 15/32)
	20	(7 - 7/8)	20	(7 - 7/8)
	21	(7 - 9/32)	21	(7 - 9/32)
	22	(8 - 21/32)	22	(8 - 21/32)
P3	18	(7 - 3/32)	20	(7 - 7/8)
P2	18	(7 - 3/32)	22	(8 - 21/32)
P1	18	(7 - 3/32)	22	(8 - 21/32)

	cm	inch	cm	inch
L	80	(31 - 1/2)	90	(35 - 7/16)
G	75	(29 - 1/2)	85	(33 - 7/16)
P	22	(8 - 21/32)	22	(8 - 21/32)
	23	(9 - 1/16)	23	(9 - 1/16)
	24	(9 - 7/16)	24	(9 - 7/16)
	25	(9 - 27/32)	25	(9 - 27/32)
	26	(10 - 1/4)	26	(10 - 1/4)
P3	22	(7 - 3/32)	24	(9 - 7/16)
P2	24	(7 - 3/32)	26	(10 - 1/4)
P1	24	(7 - 3/32)	26	(10 - 1/4)

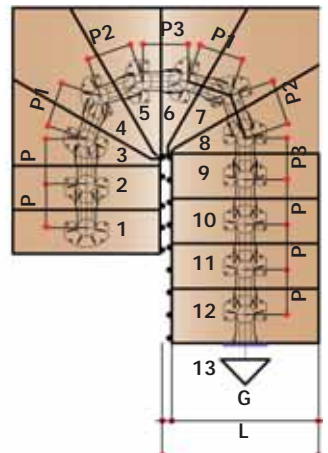
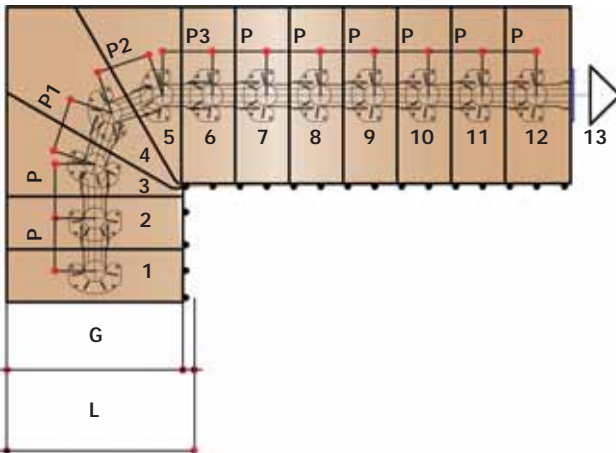
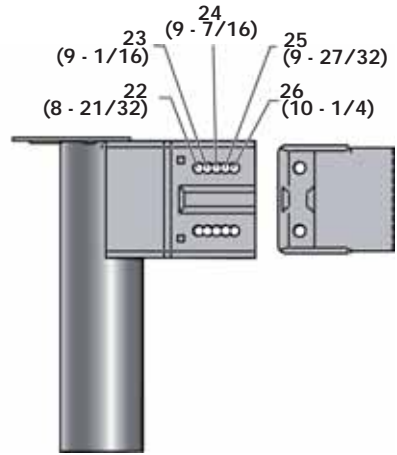
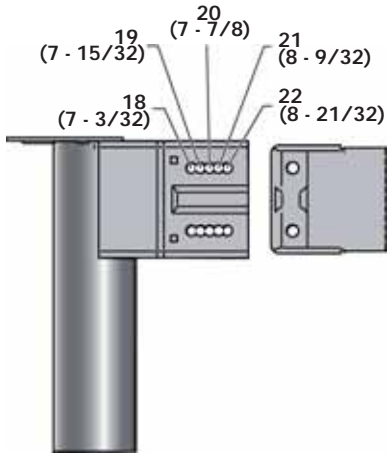

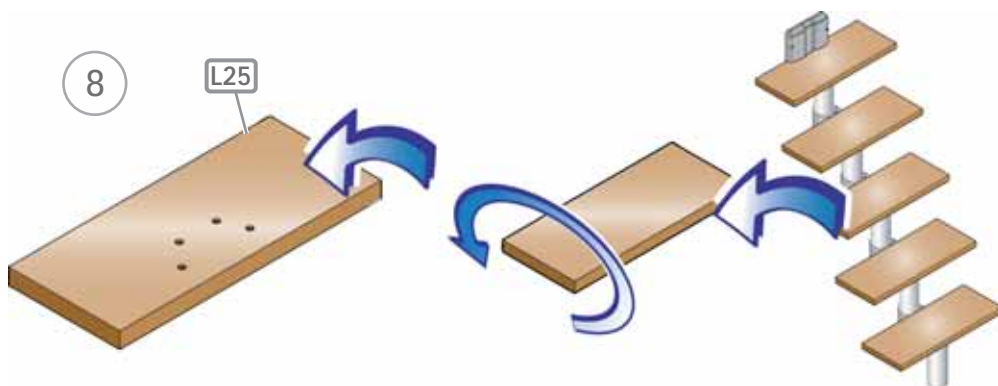
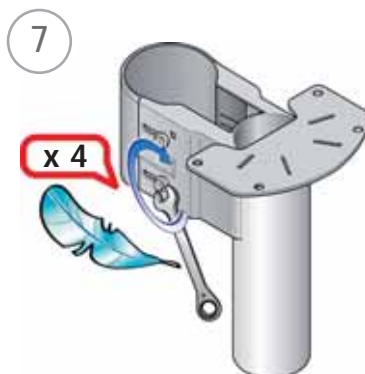
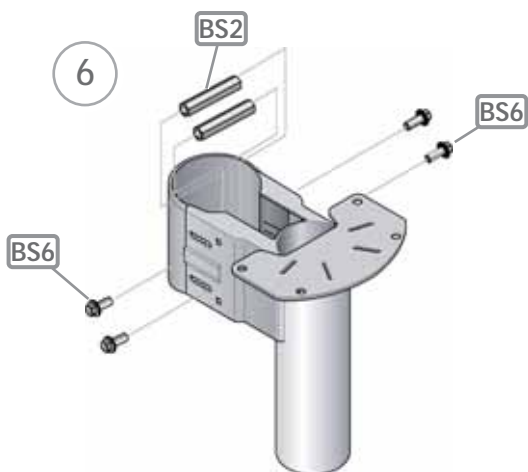
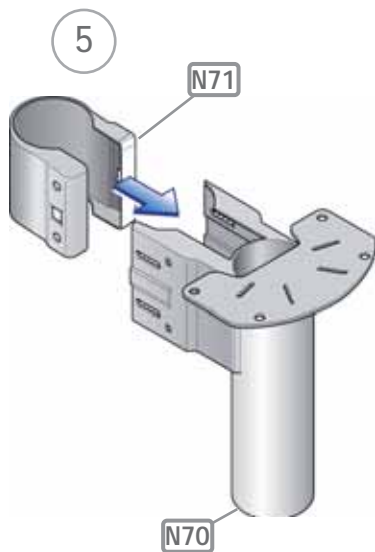

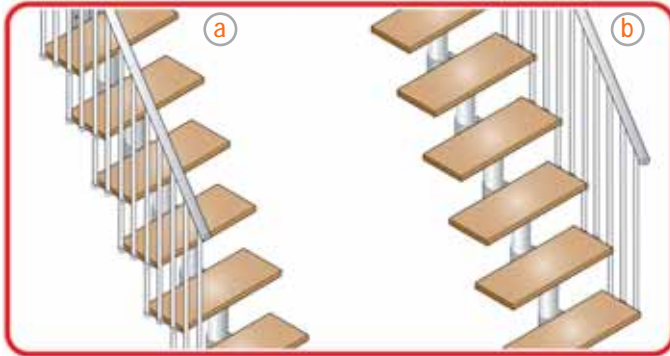

9 a

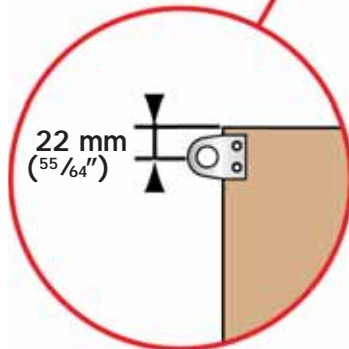
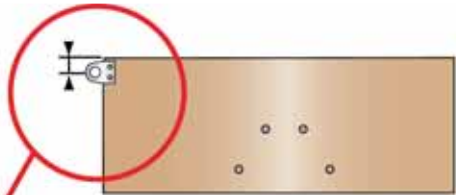
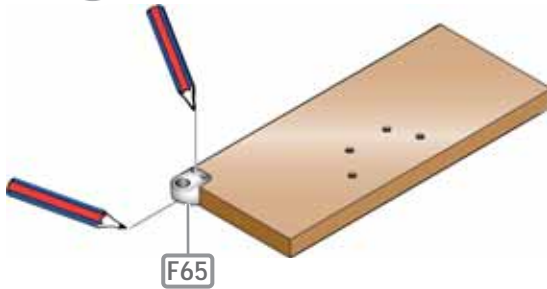

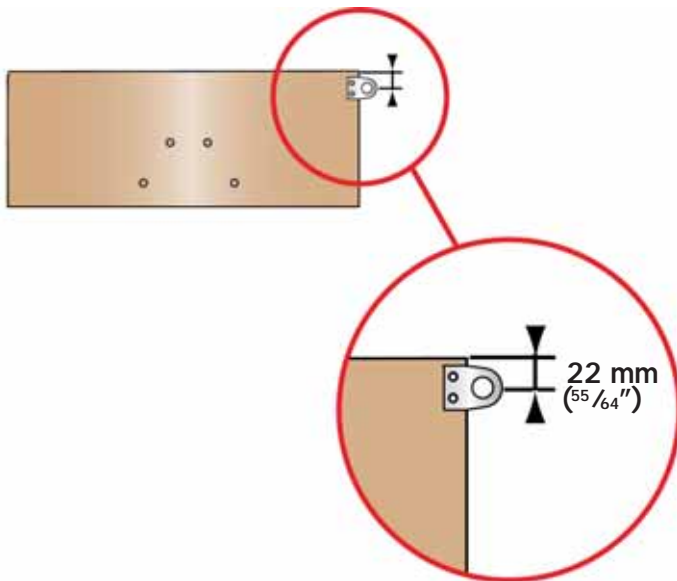
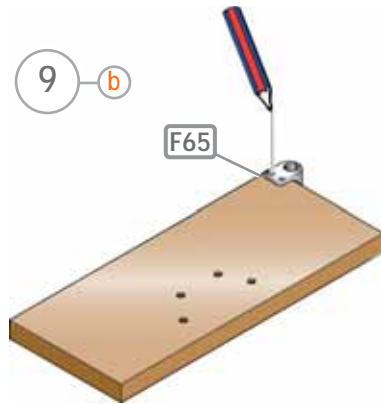

10

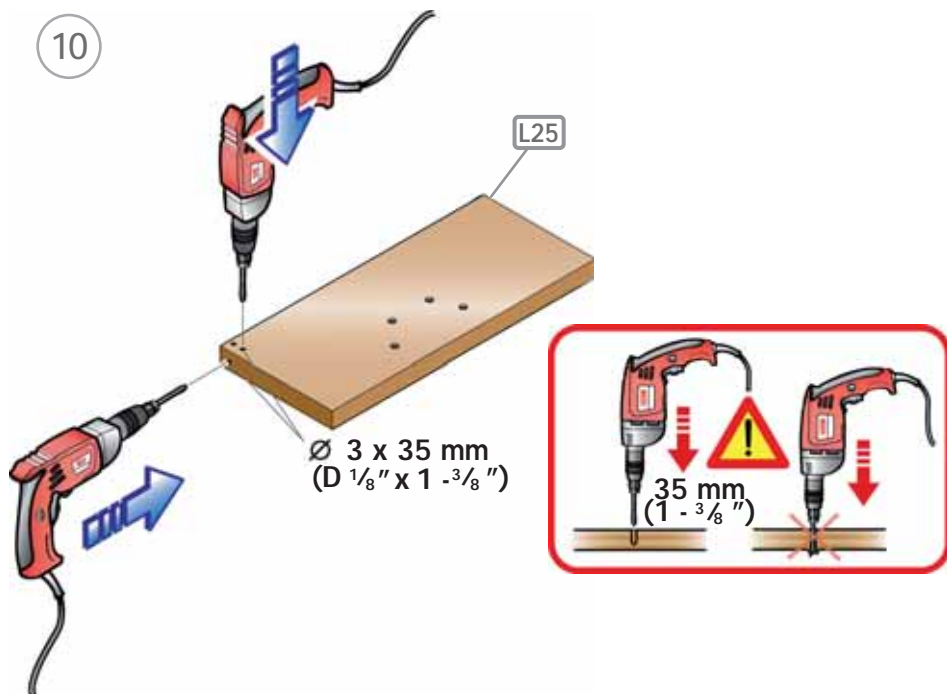

11



12

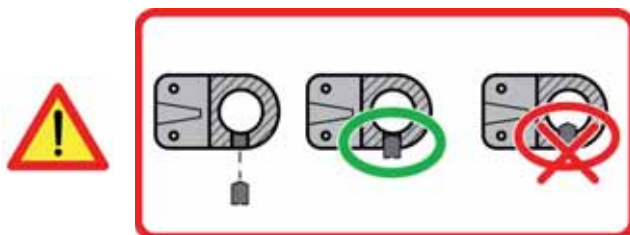

13

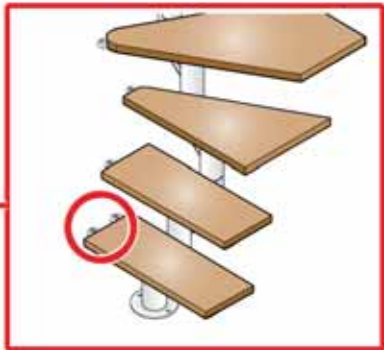
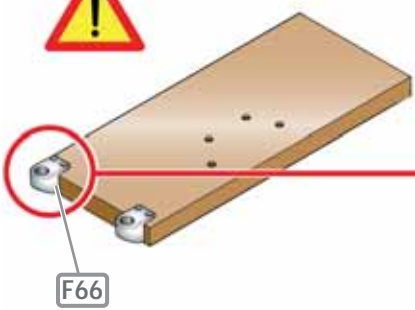
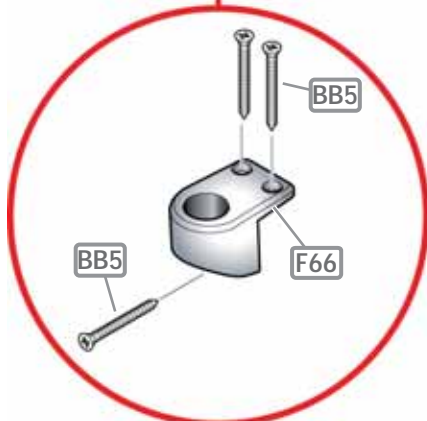
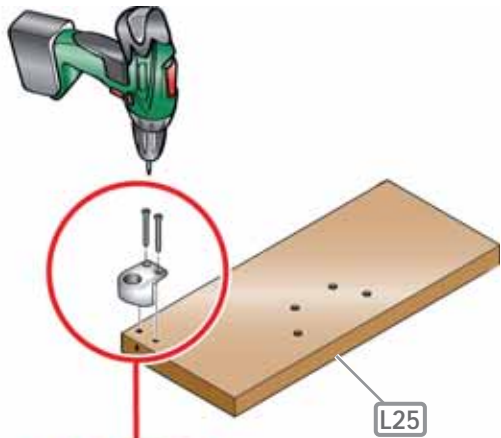



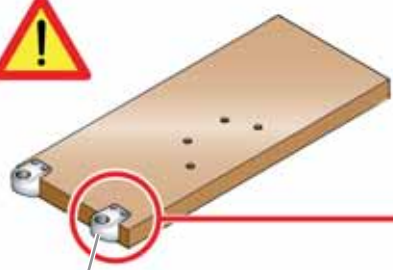

F65

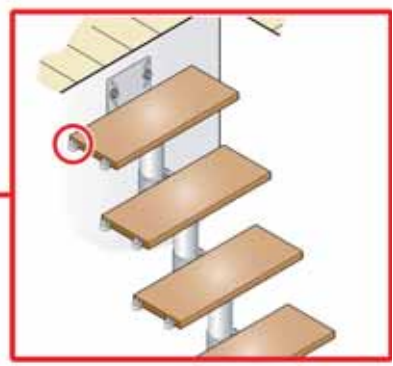

14

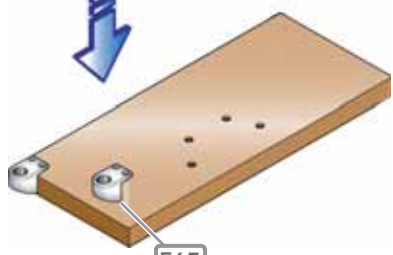

F65

15

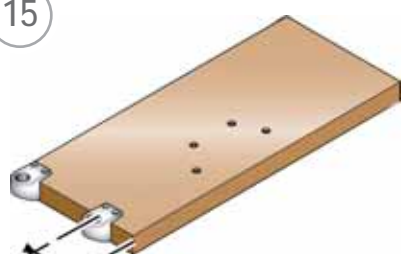

4 cm  
(1 - 37/64")

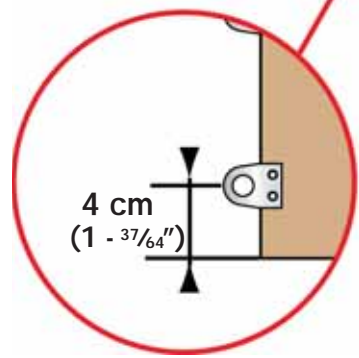
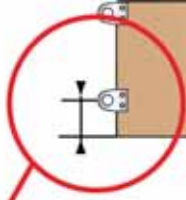

4 cm  
(1 - 37/64")

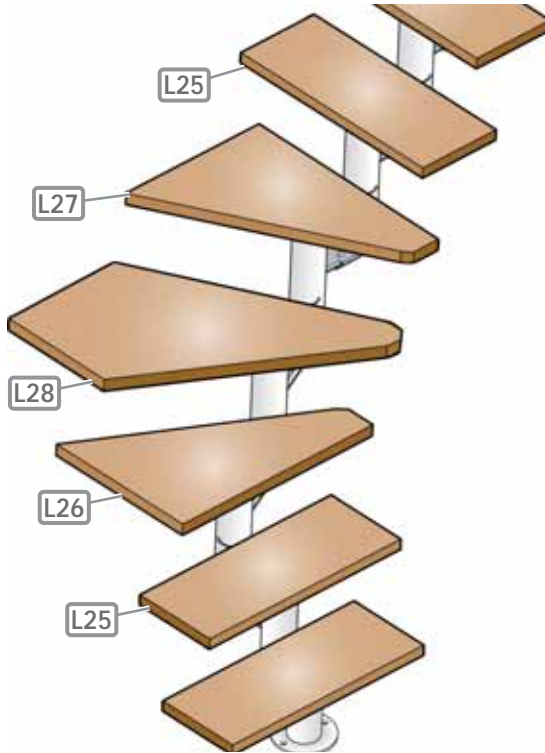

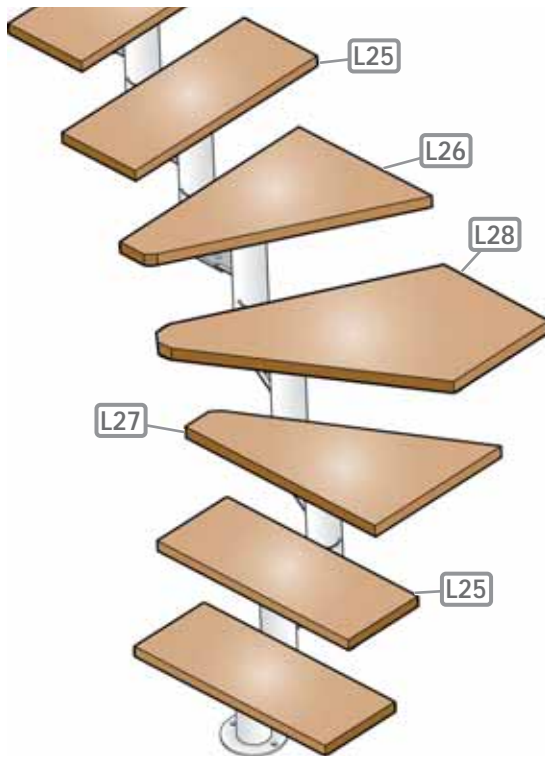

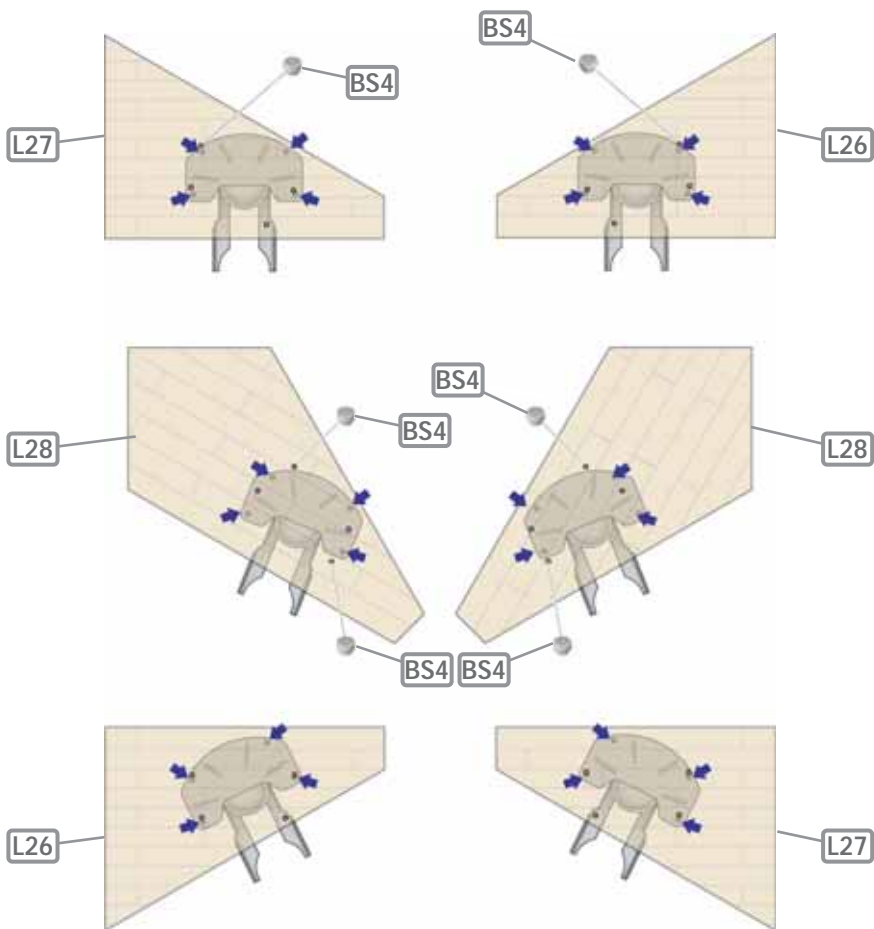
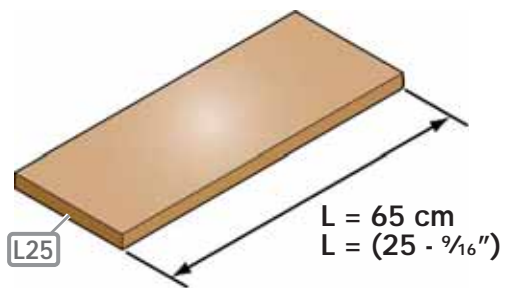

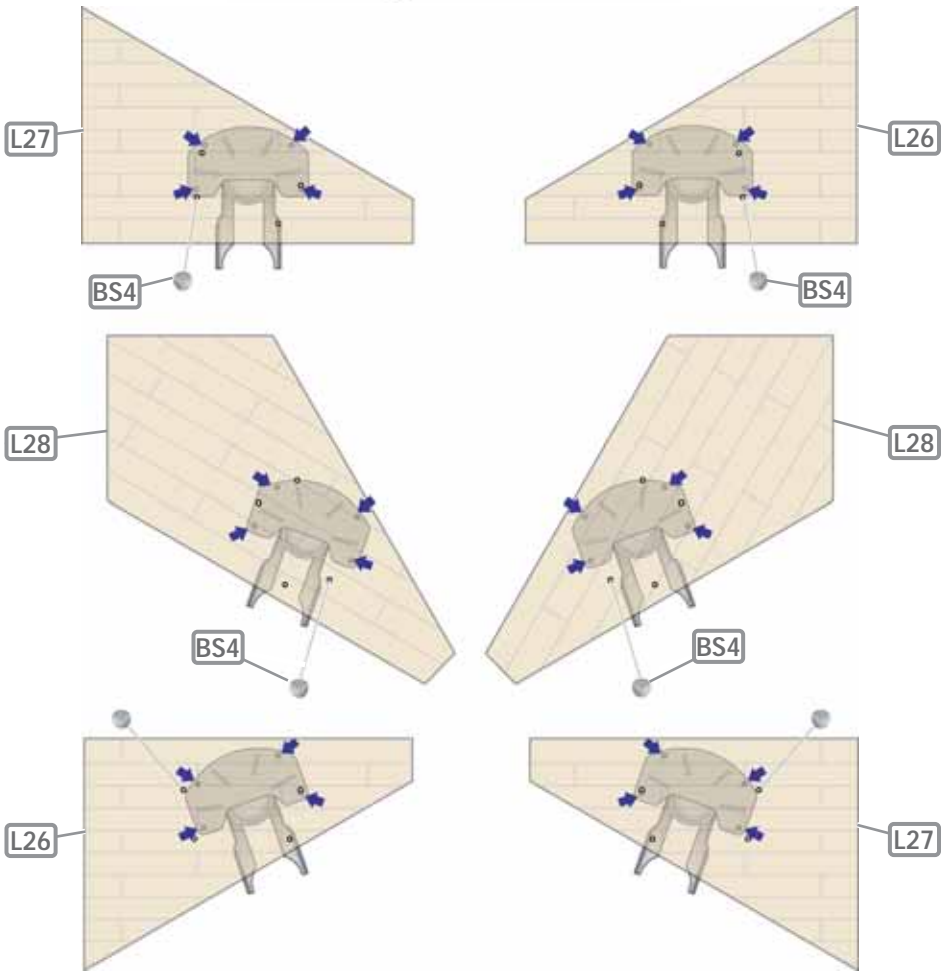
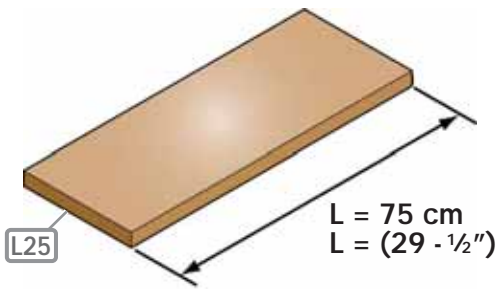

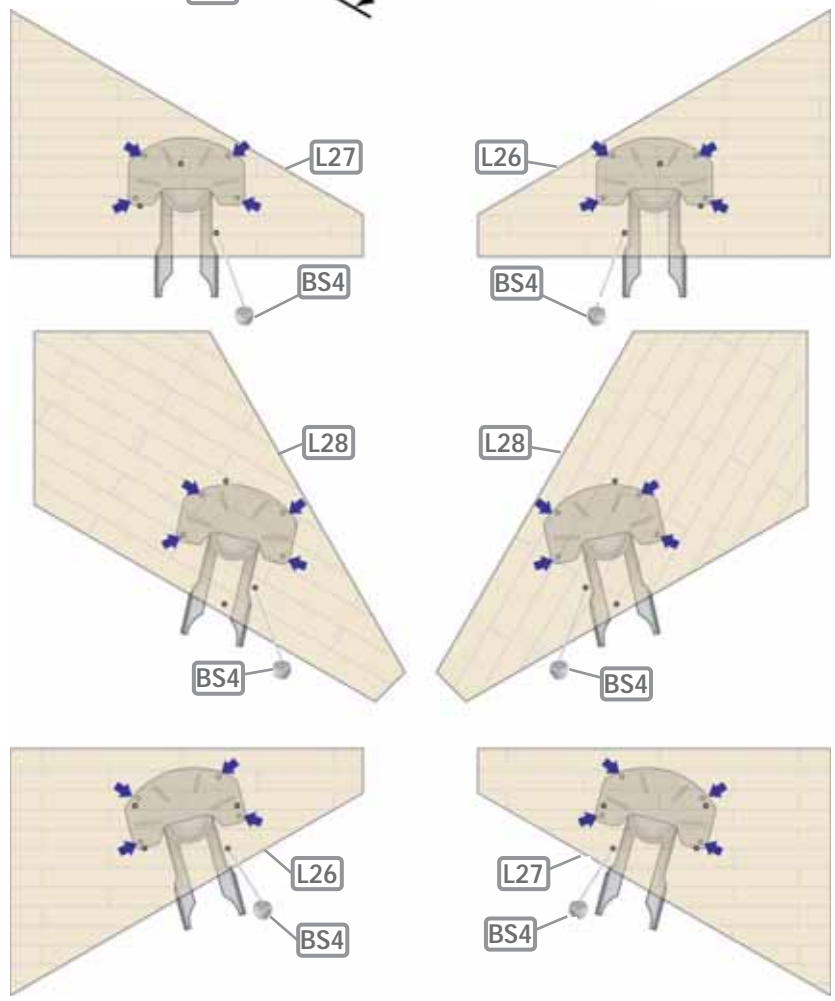
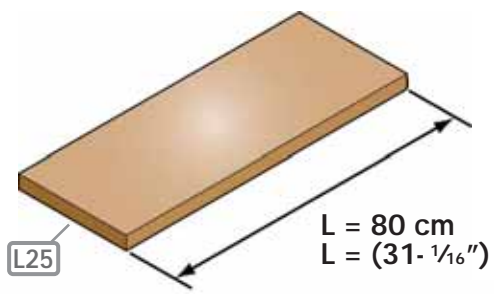

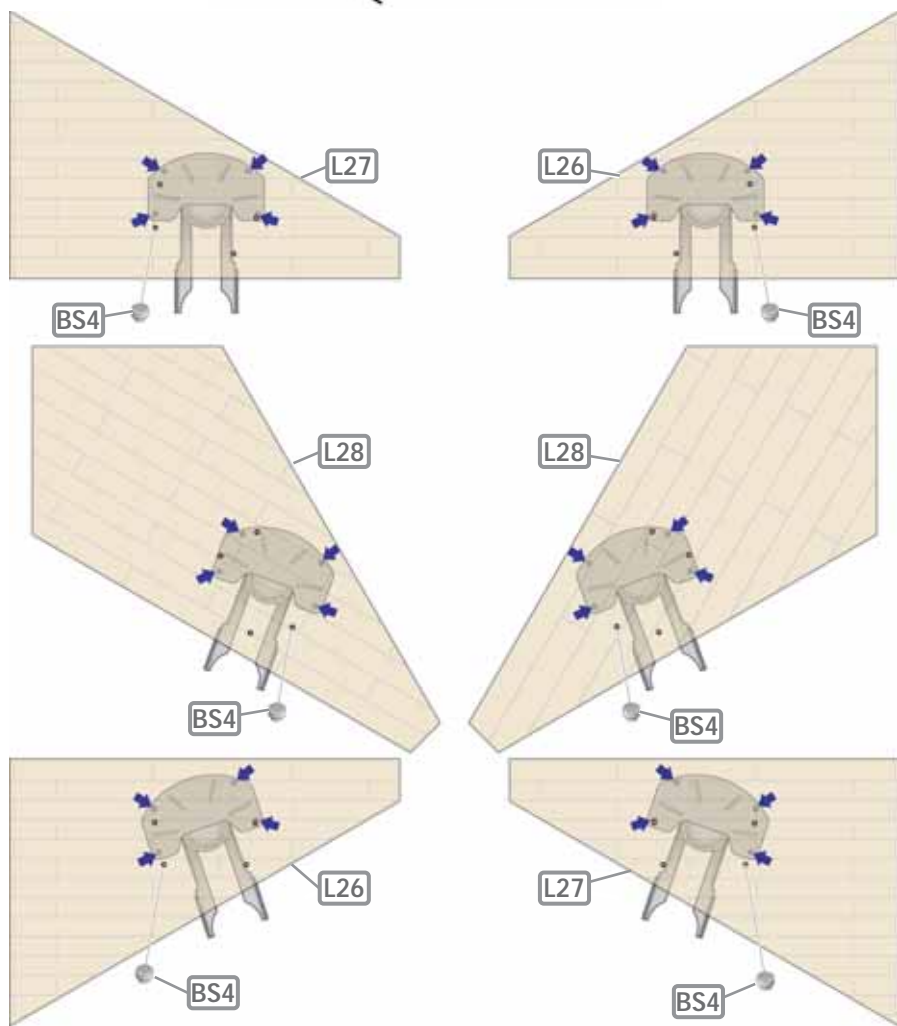
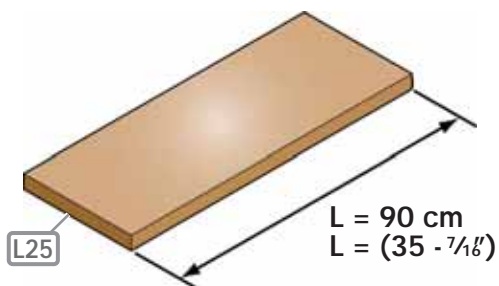

16



$$Q = A + 4 \text{ cm}$$

$$Q = A + (1 - 3/64)$$

17

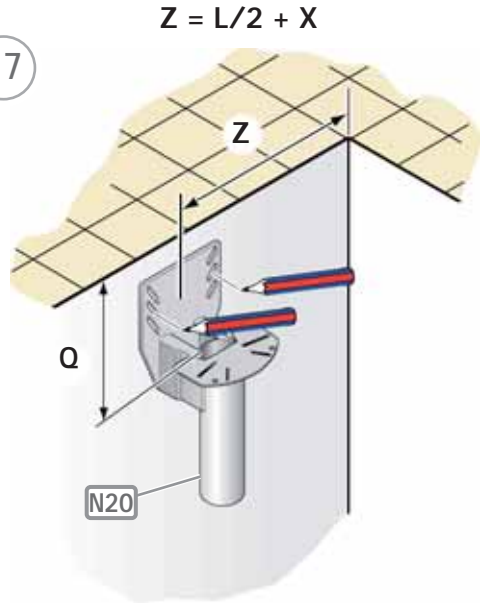

$$Z = L/2 + X$$

18

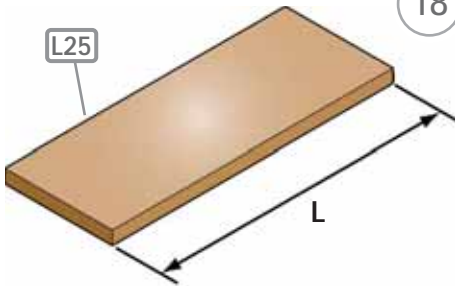

$$X = 2 \div 6 \text{ cm}$$

$$X = (25/32") \div (2 - 3/8")$$

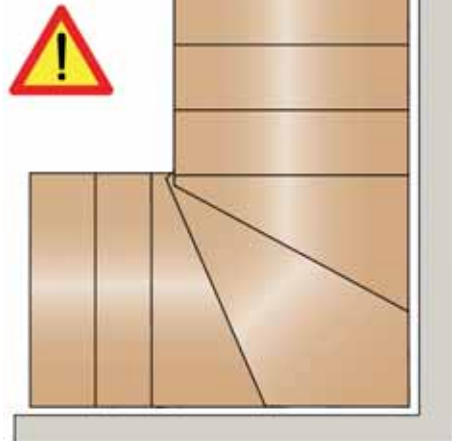
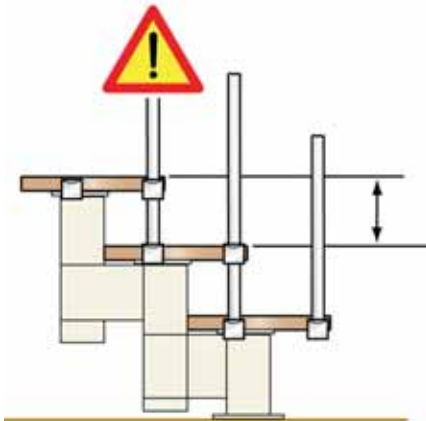



19

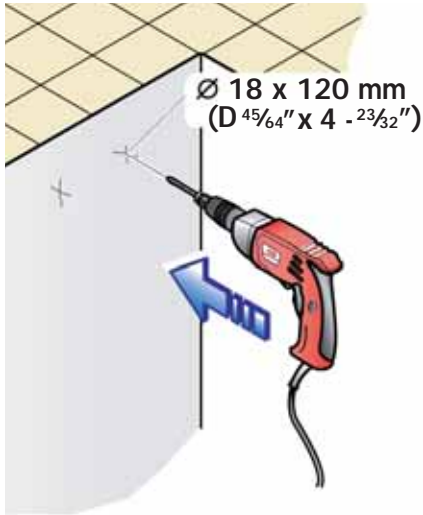

20

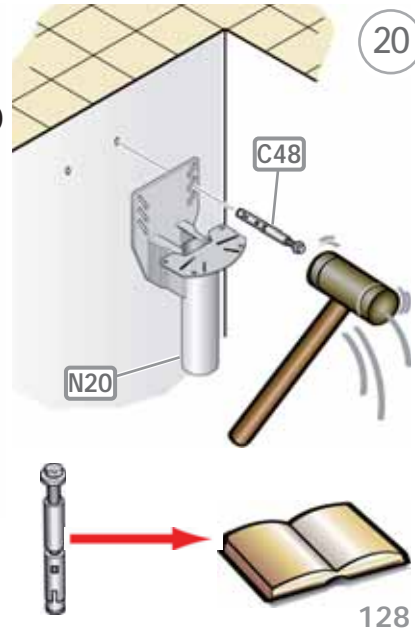

21

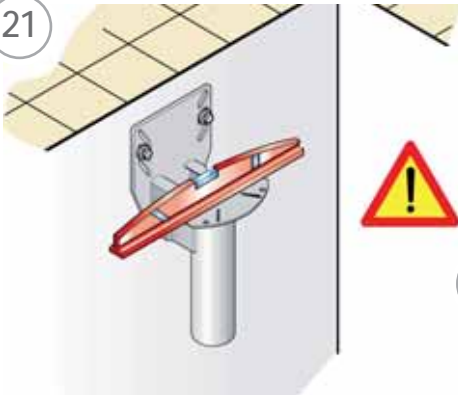

22

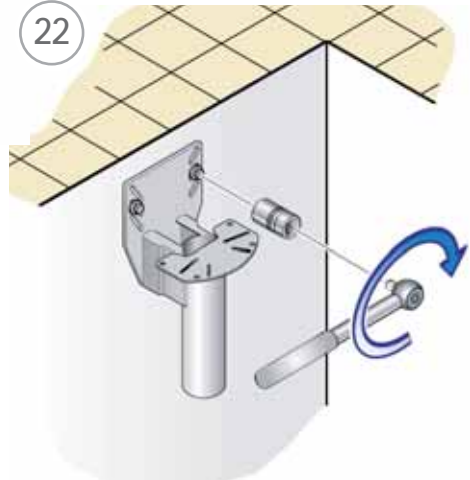

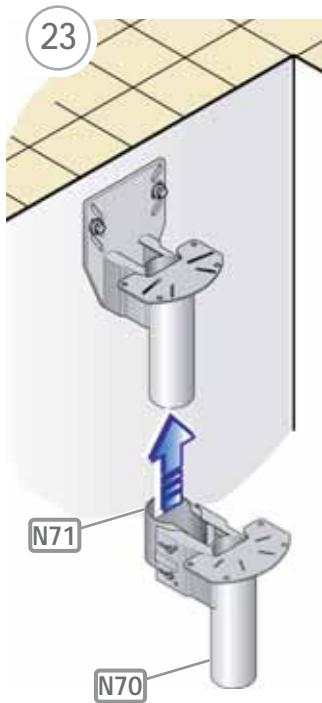

24

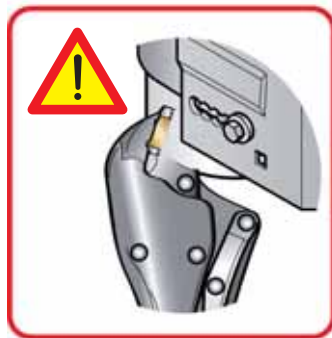
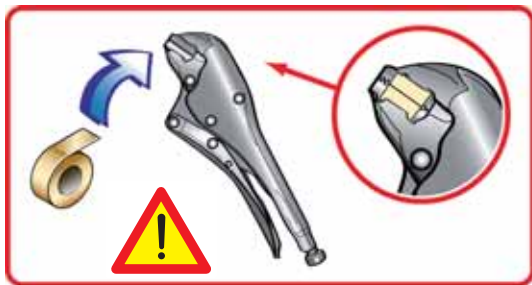
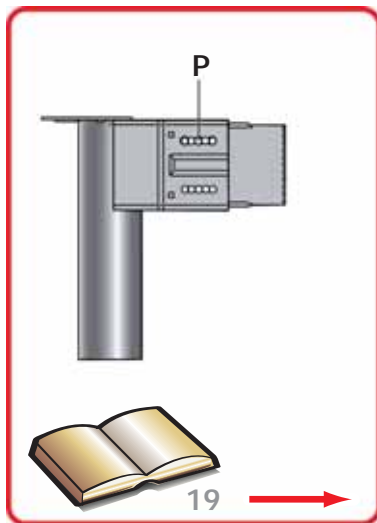
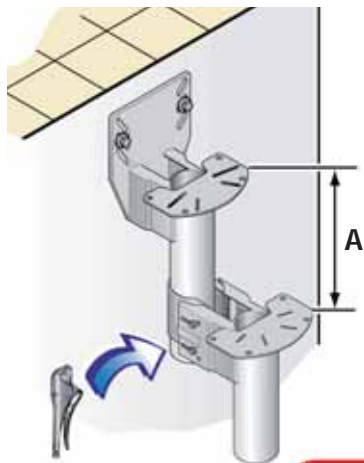

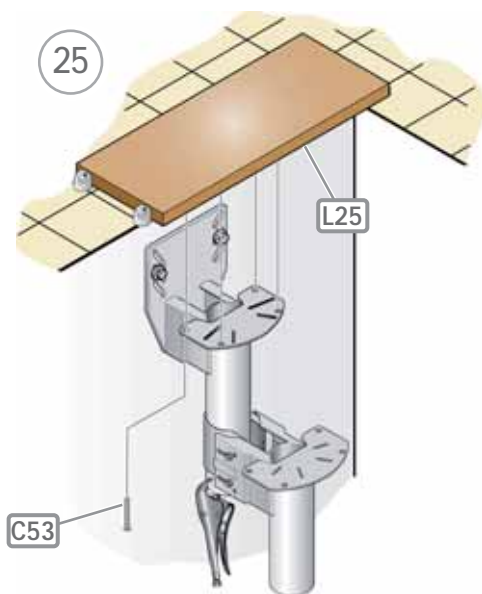

25

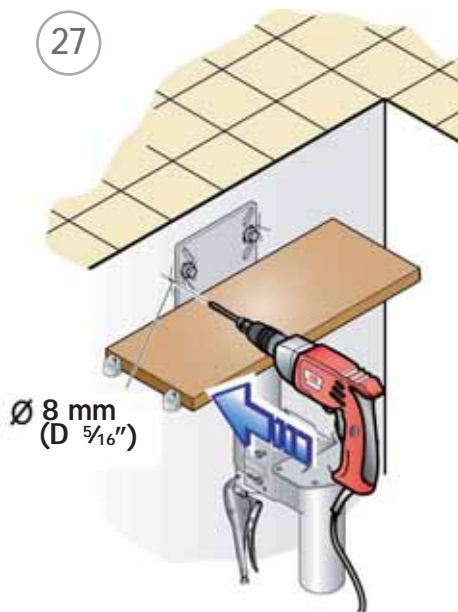
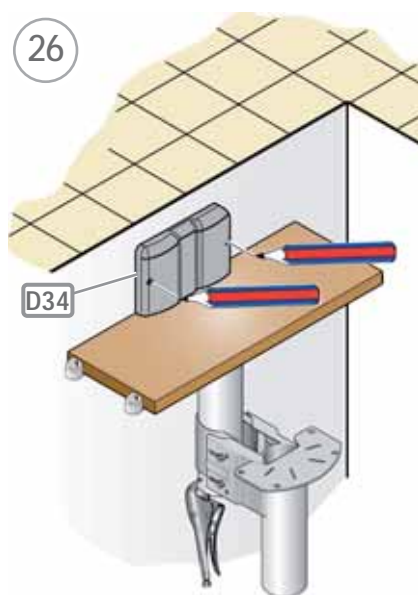

28

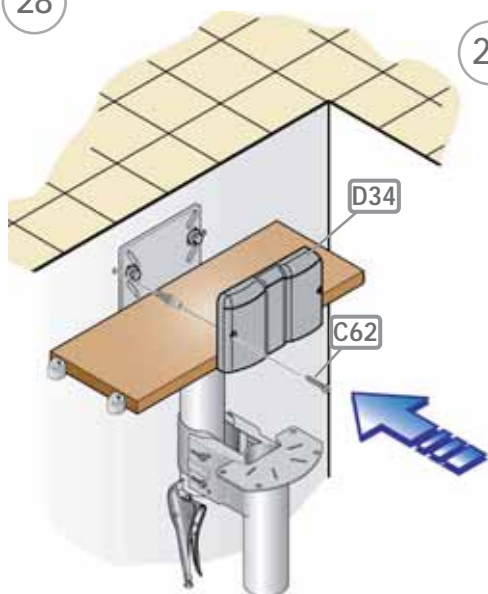

29

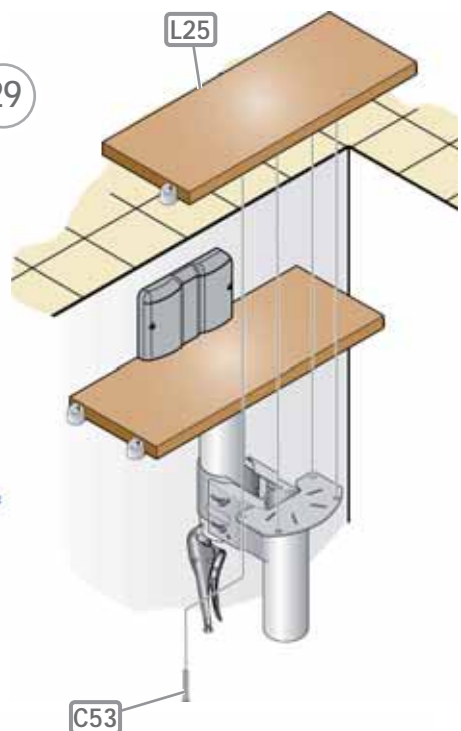

30

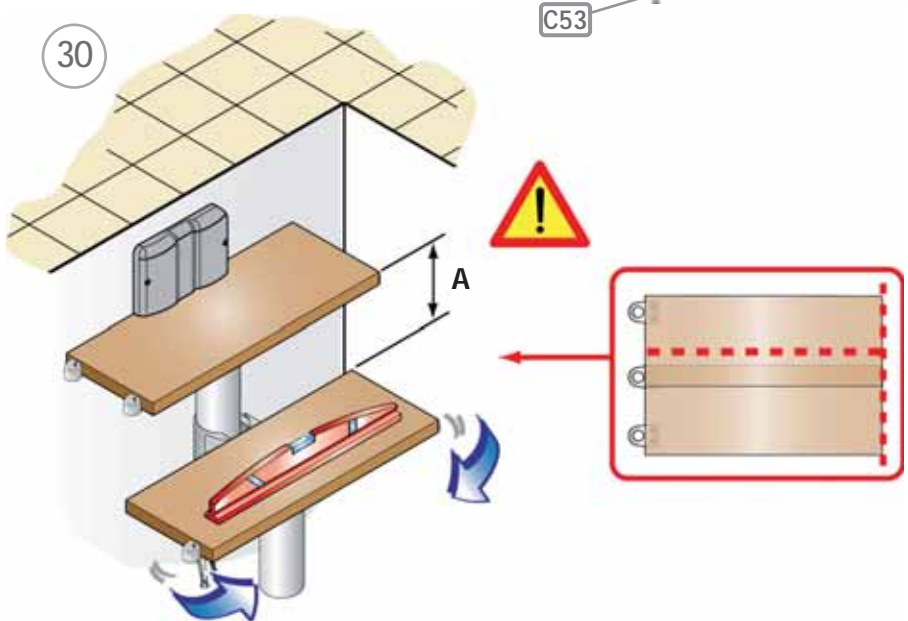

31

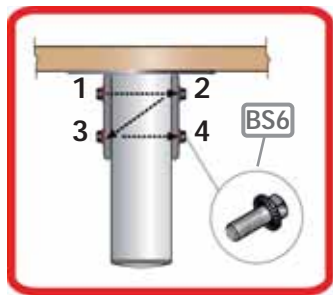
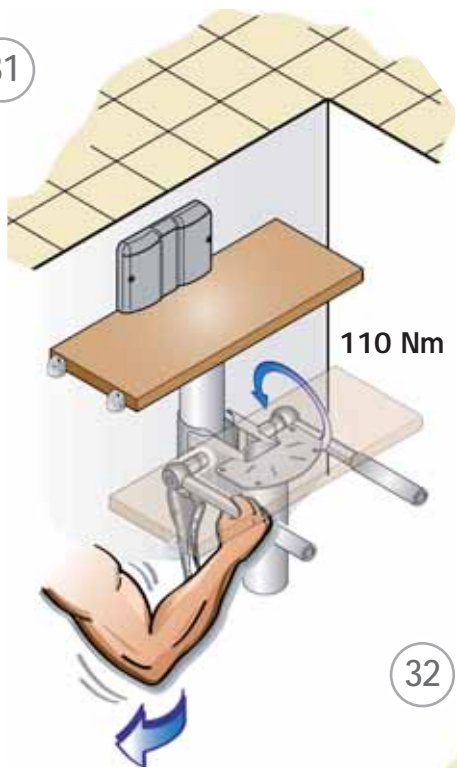

32

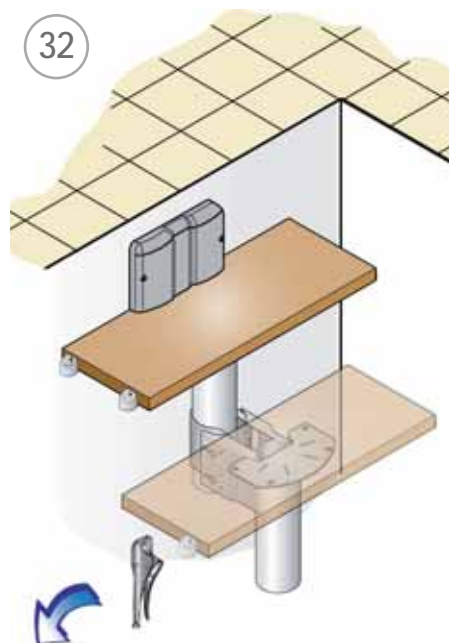

33

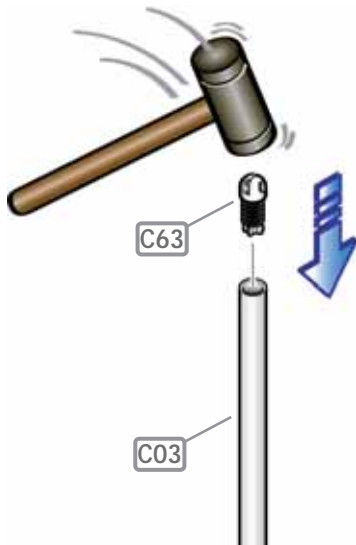

34

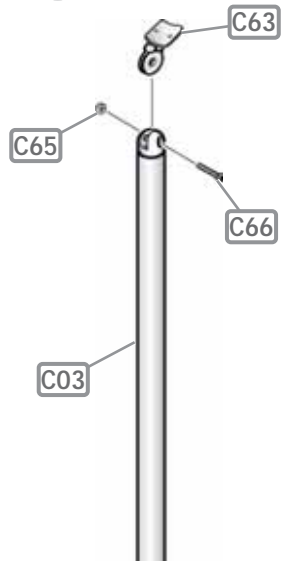

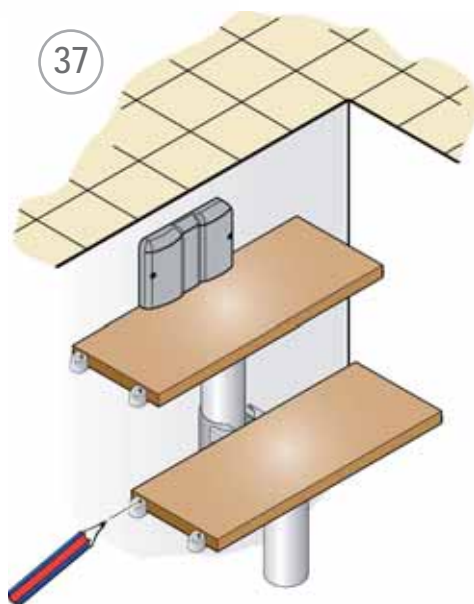
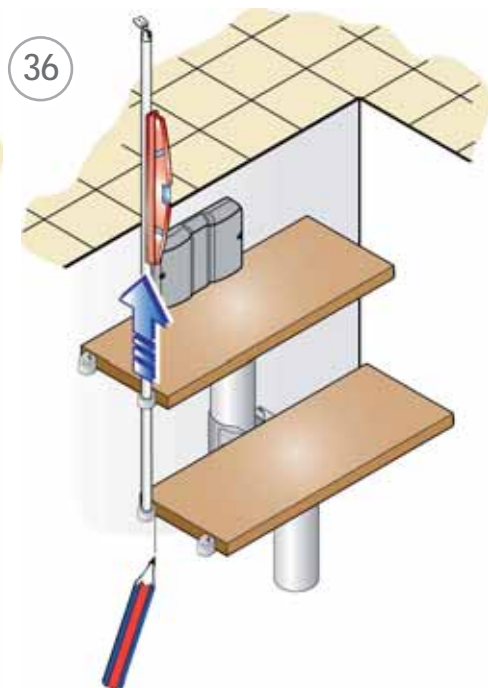
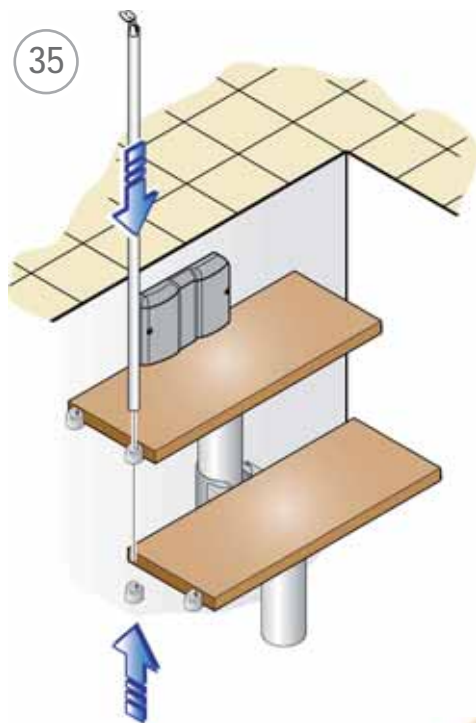



38

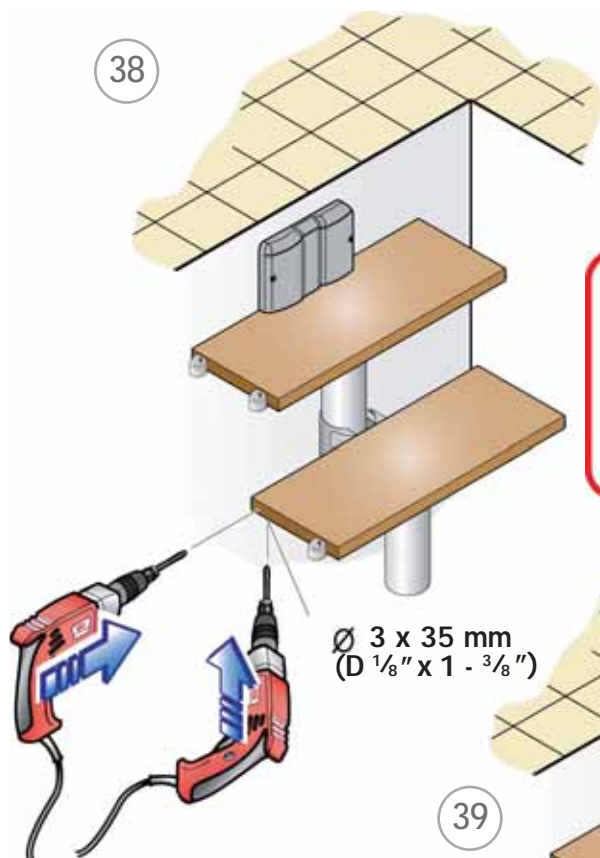

Ø 3 x 35 mm  
(D 1/8" x 1 - 3/8")

39

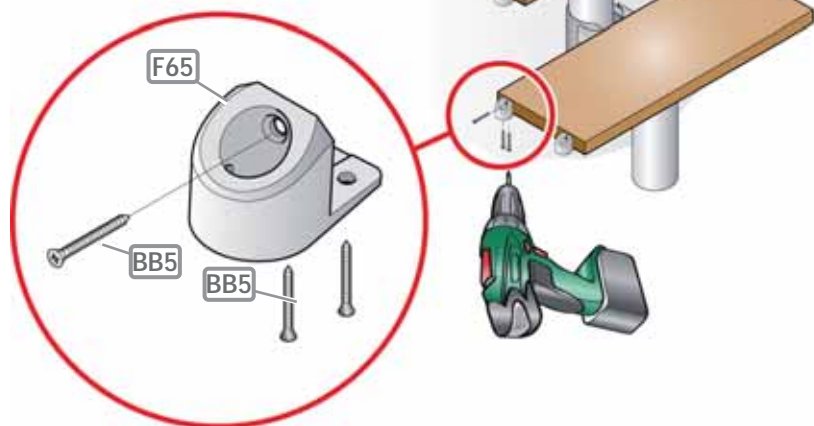



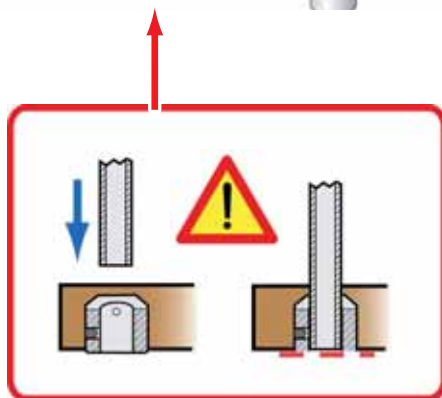
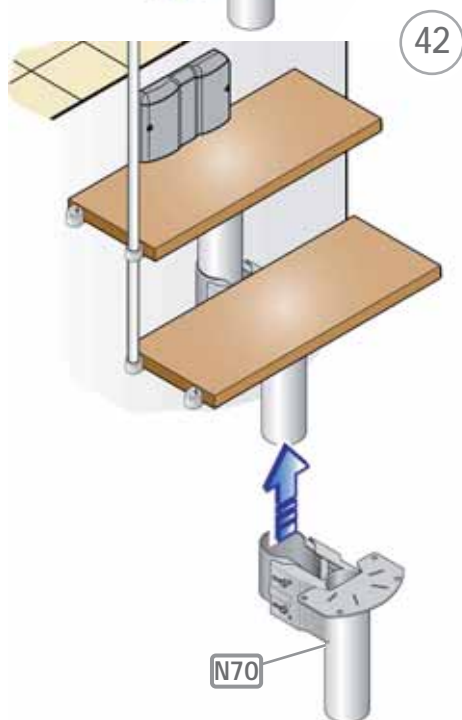
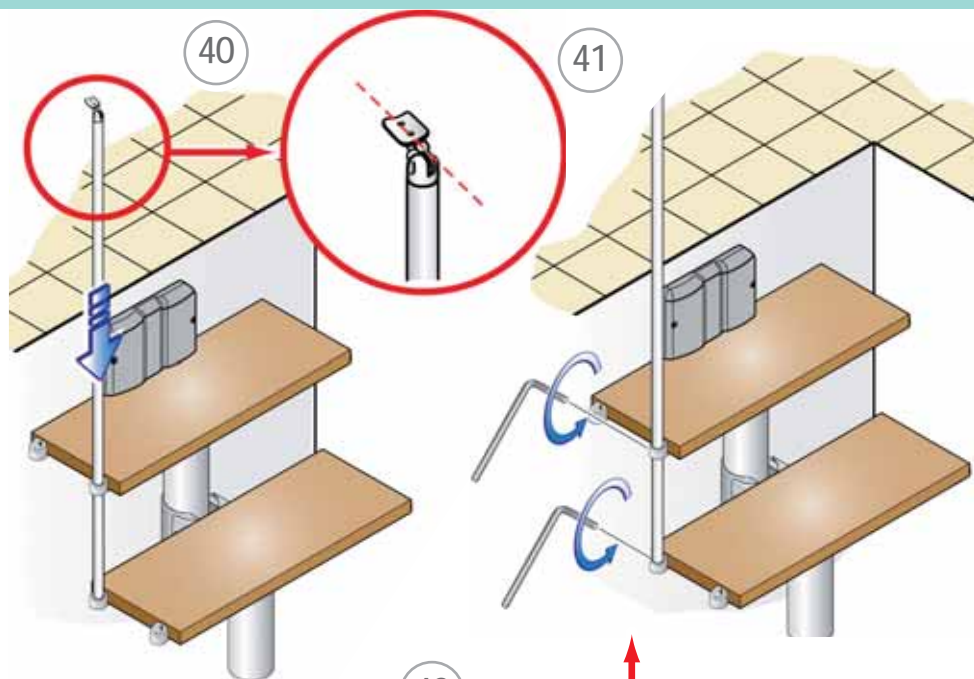

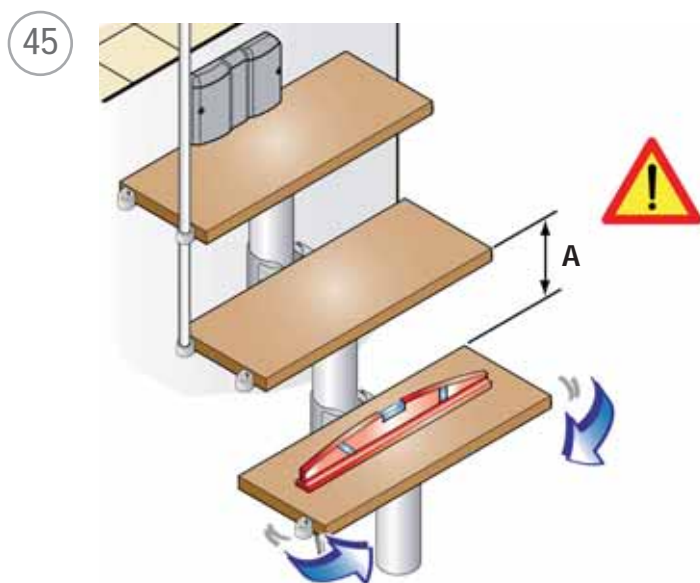
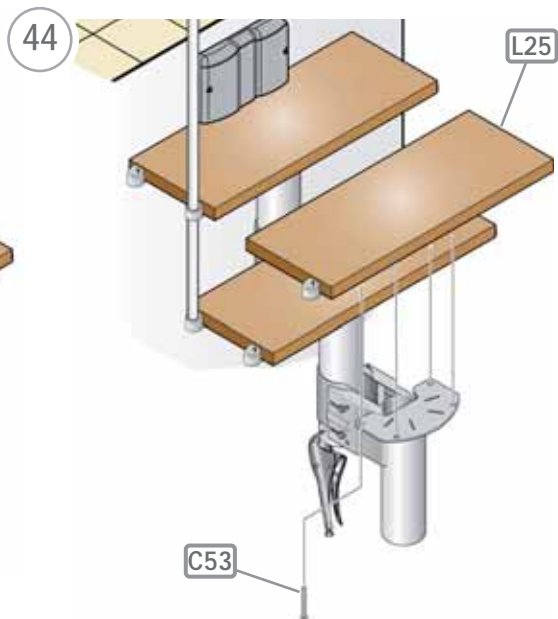
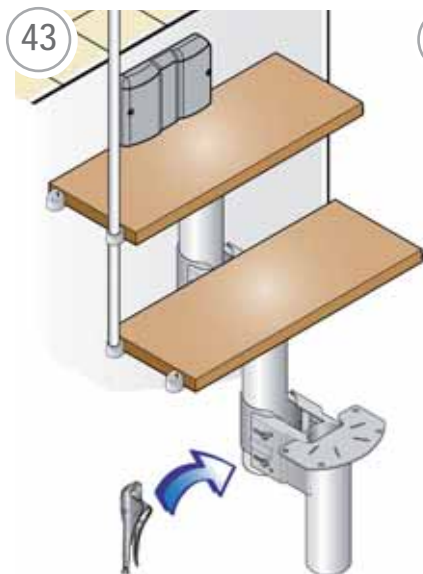

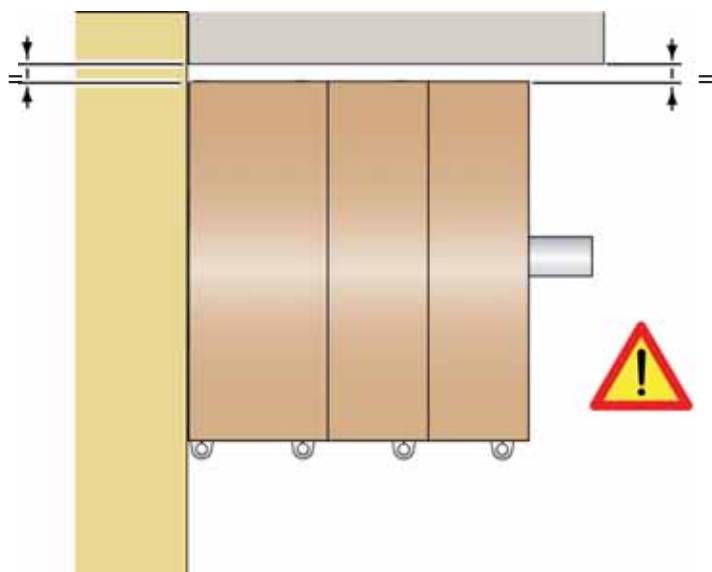

46

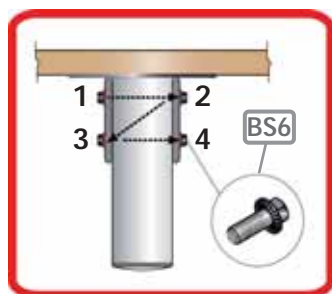
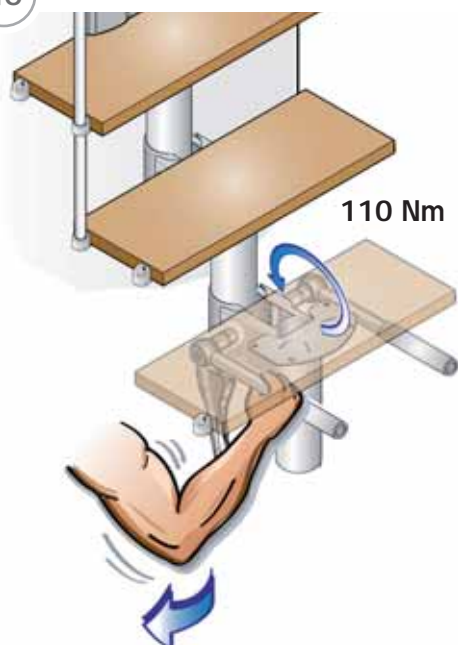

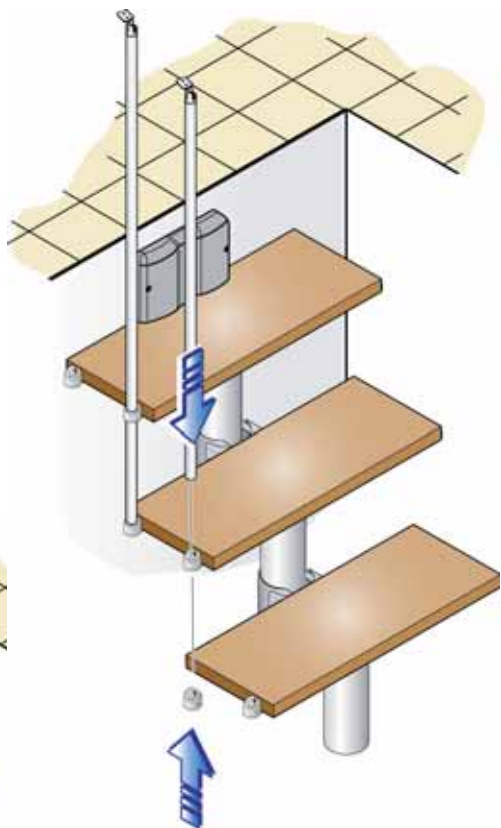
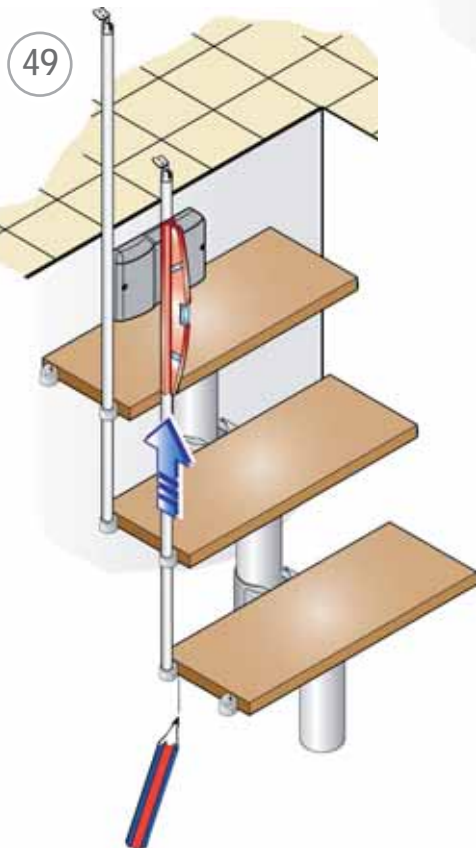
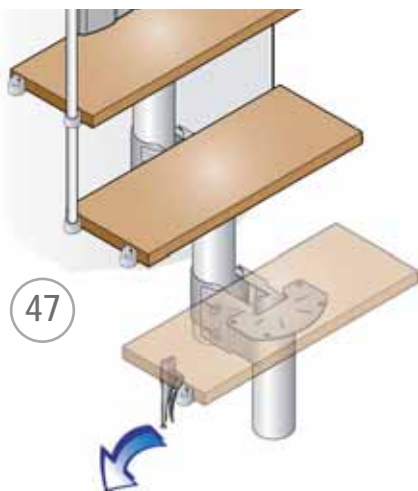

50

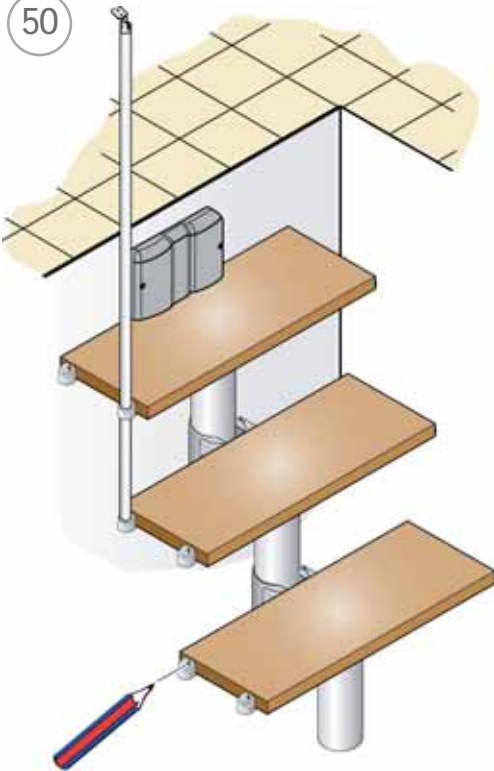

51

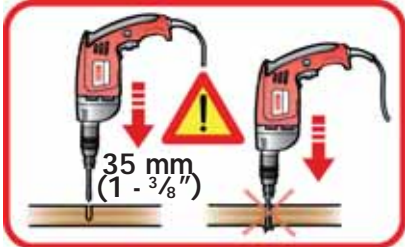
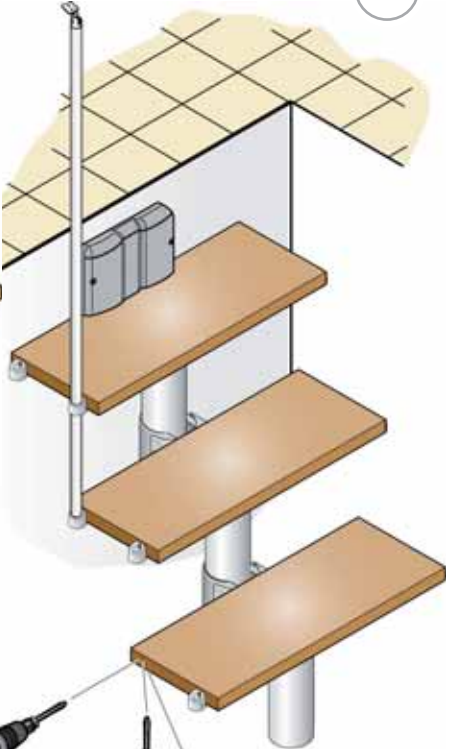

35 mm  
(1 - 3/8")

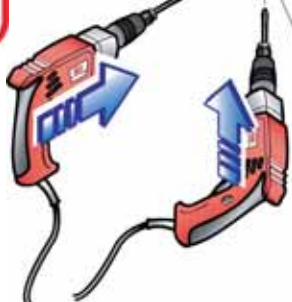

Ø 3 x 35 mm  
(D 1/8" x 1 - 3/8")

52

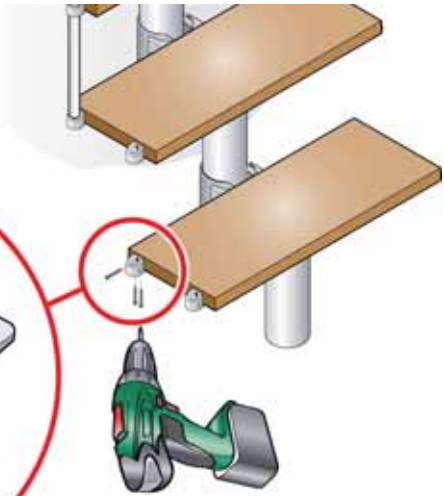
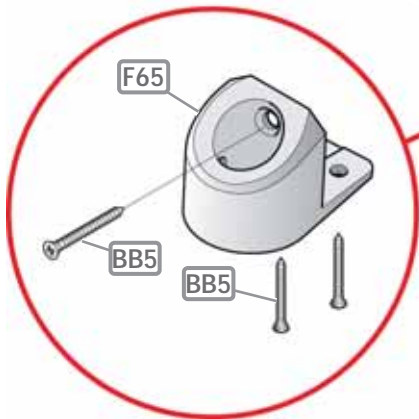

54

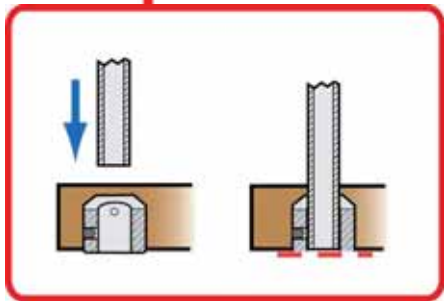
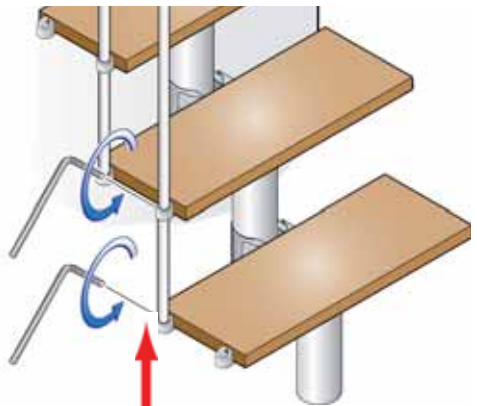

53

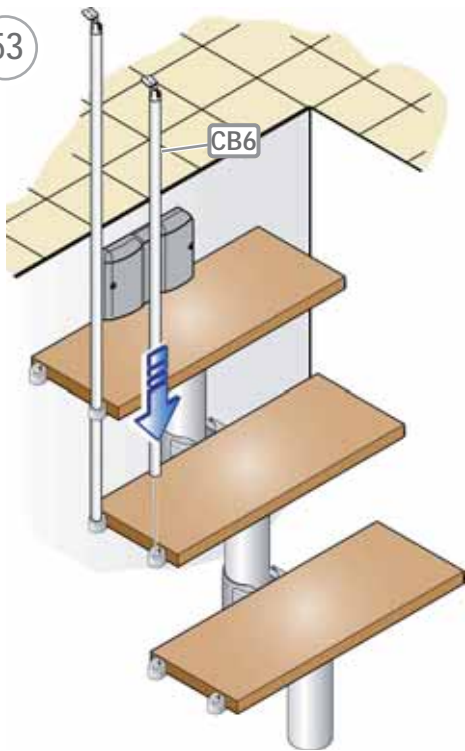



55

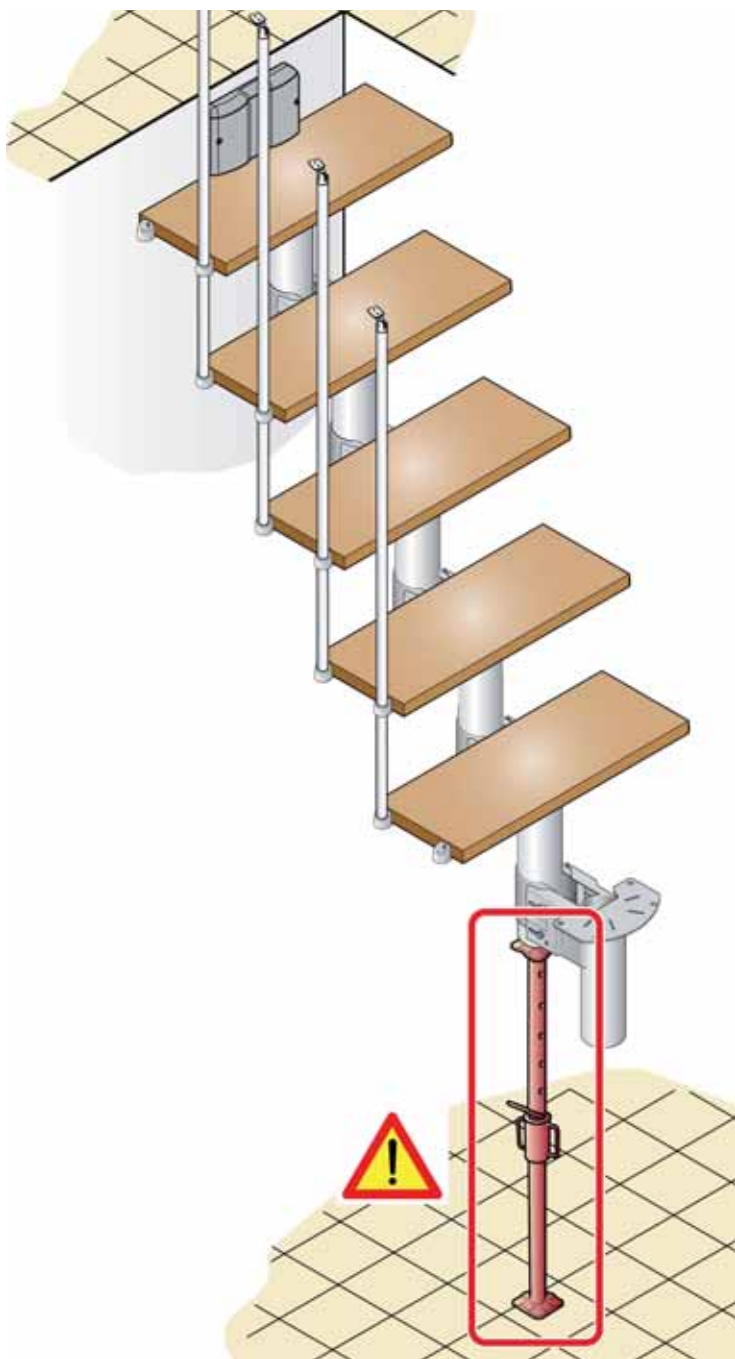

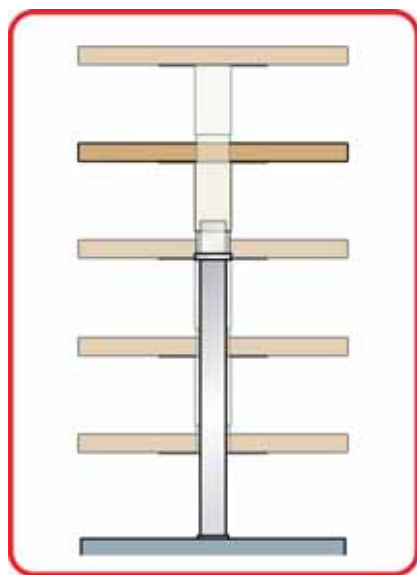



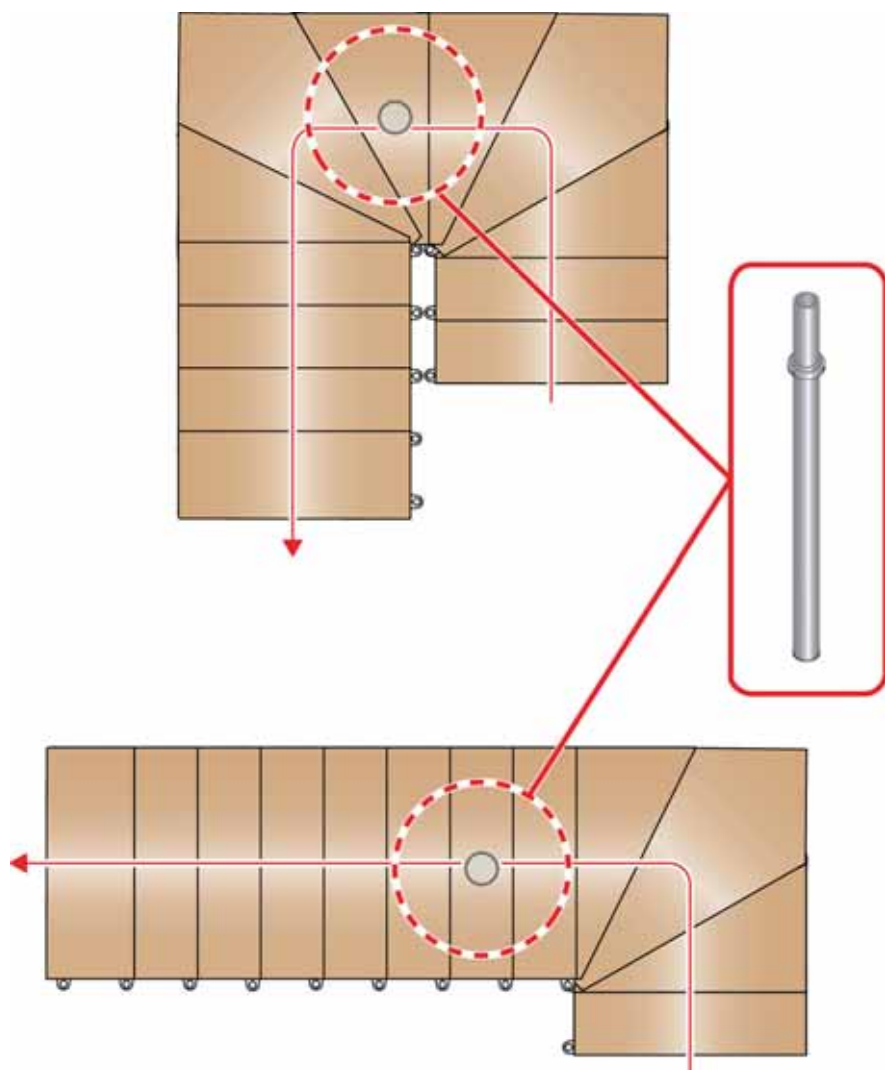

57



58

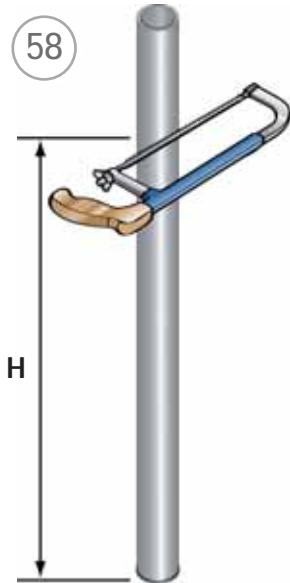

$$H = H1 + 8 \text{ cm}$$

$$(H = H1 + 3 \text{ - } \frac{5}{32} \text{''})$$

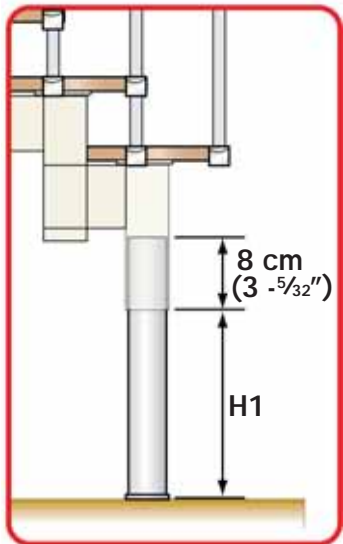

59

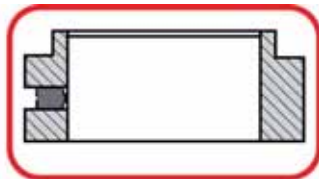

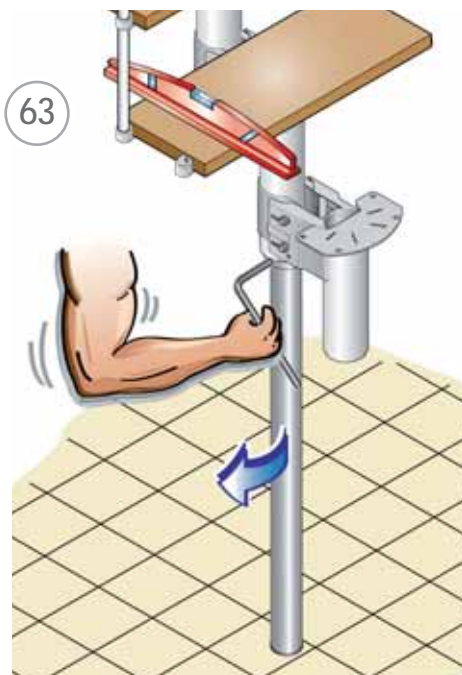
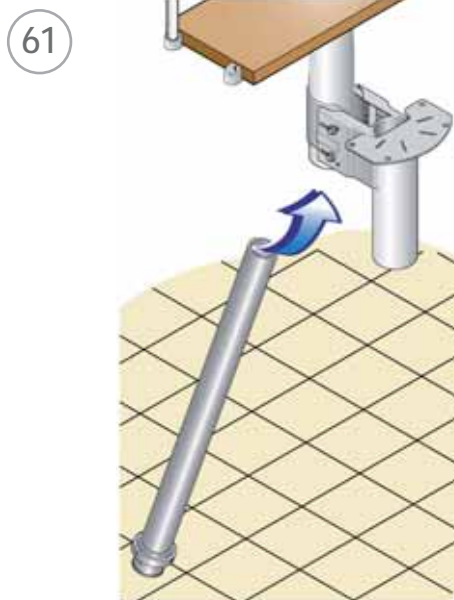
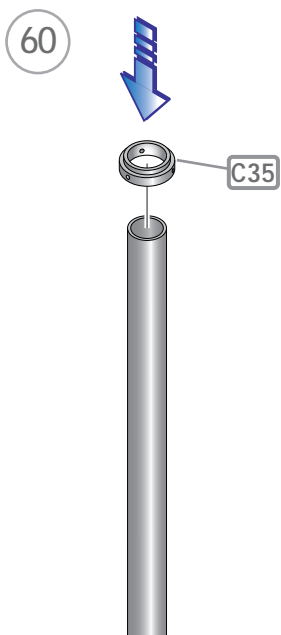

64

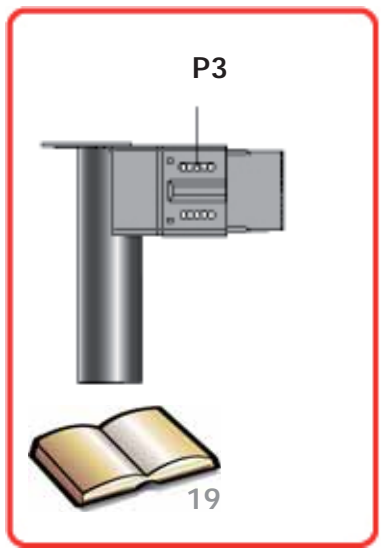
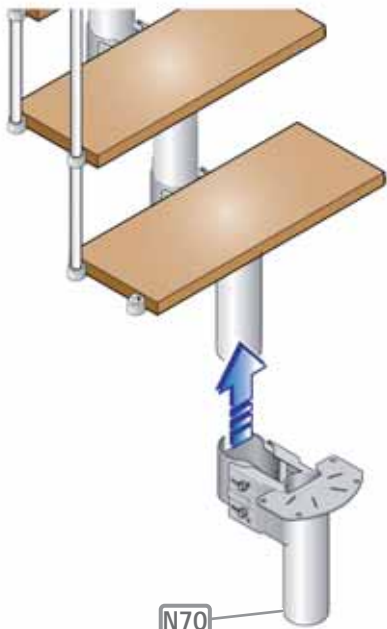

N70

65

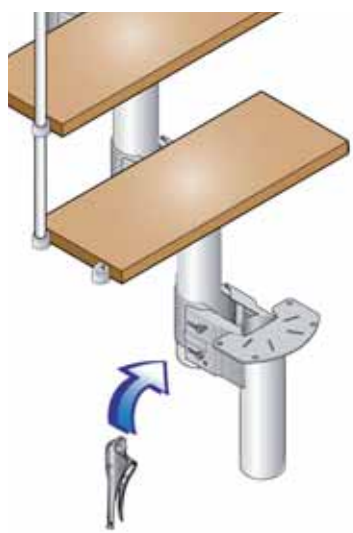

66

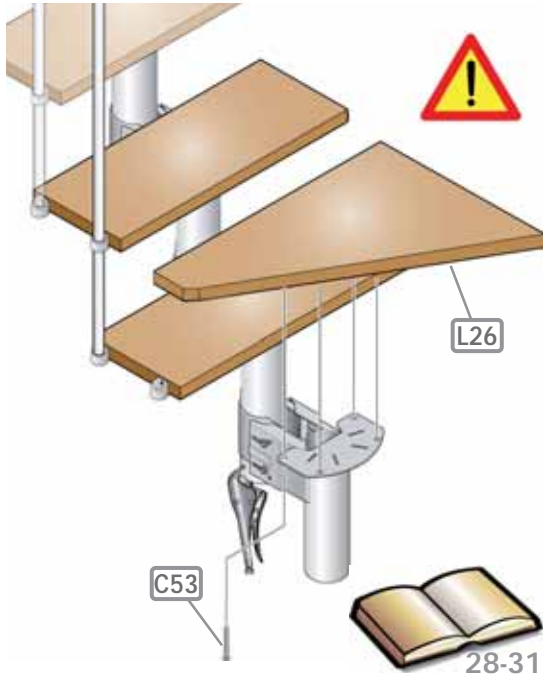

L26

C53

28-31

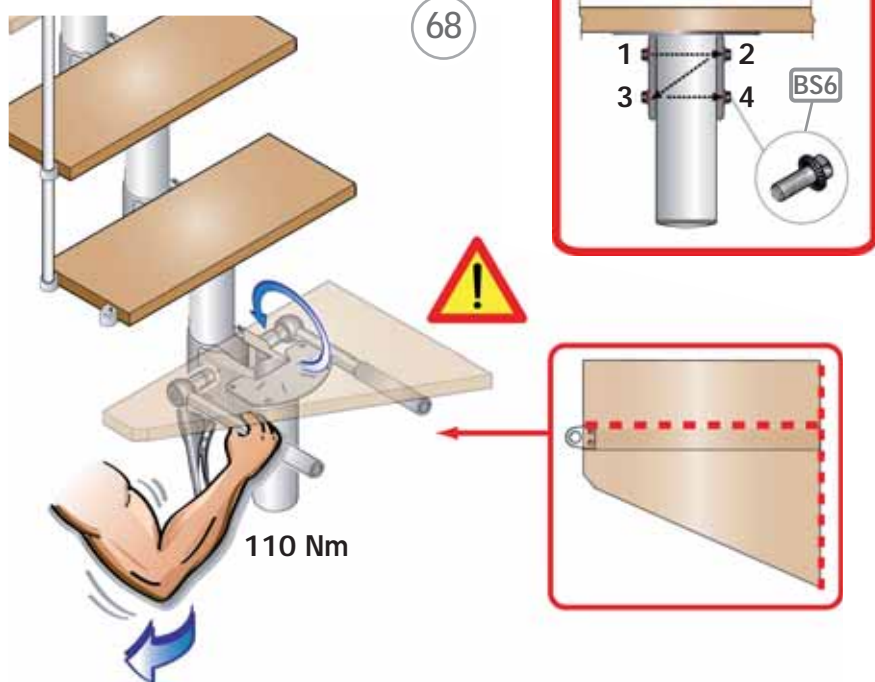
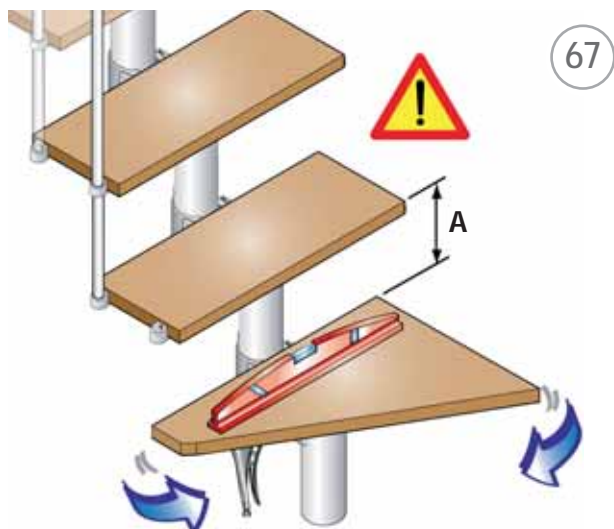

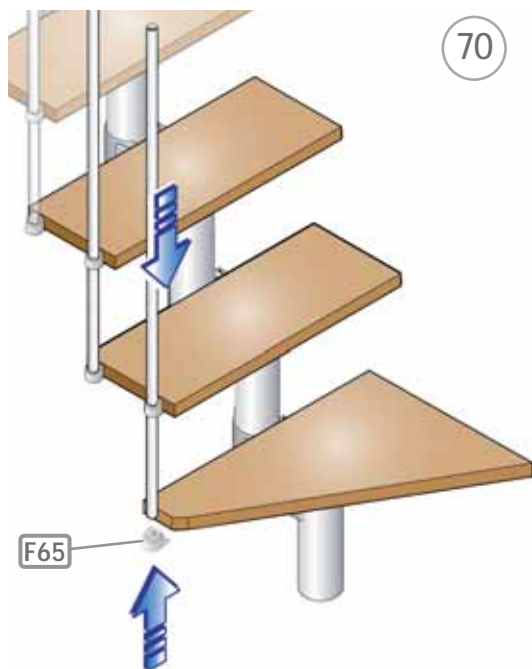
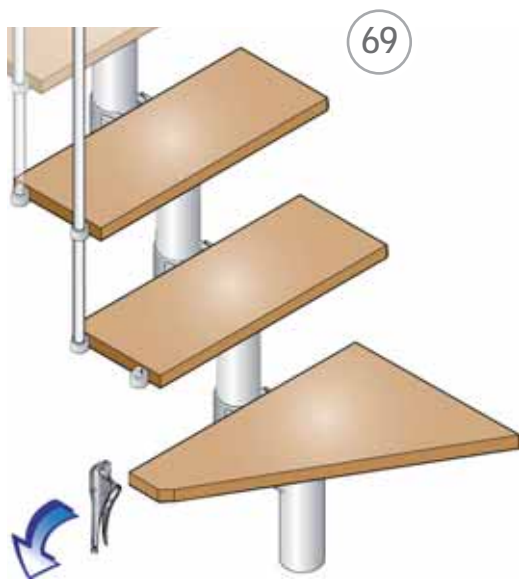

71

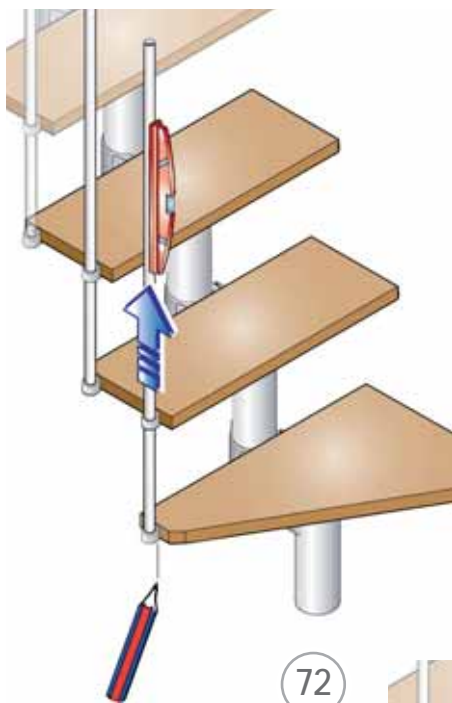

72

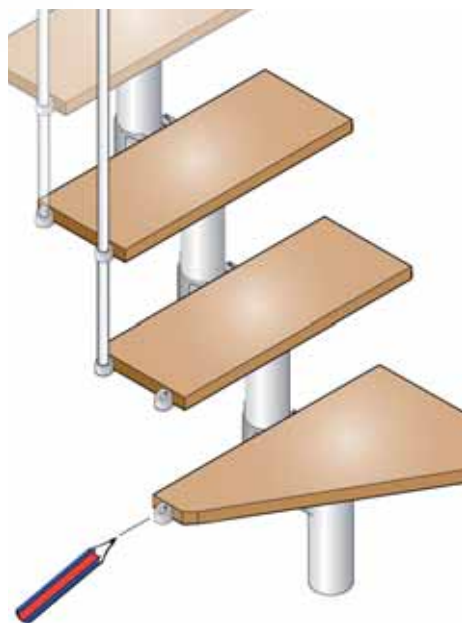

73

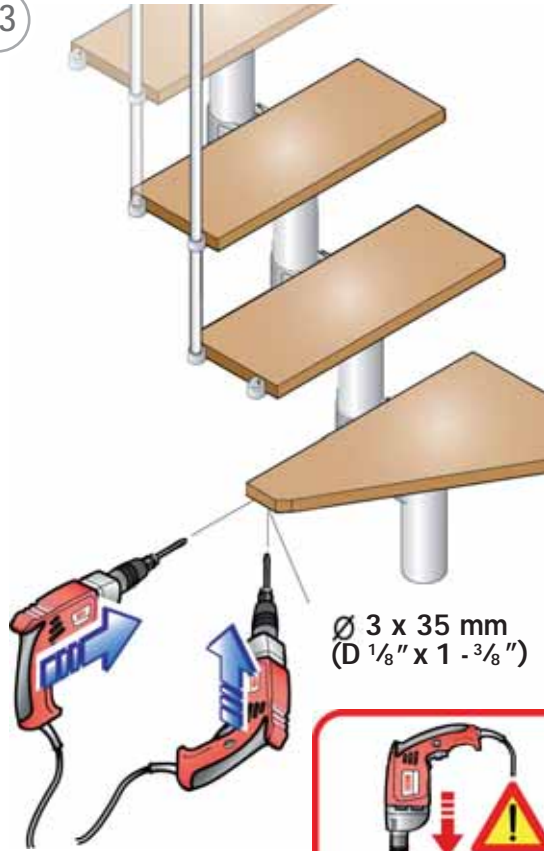

Ø 3 x 35 mm  
(D 1/8" x 1 - 3/8")

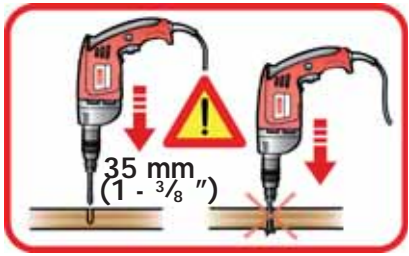

35 mm  
(1 - 3/8")

74

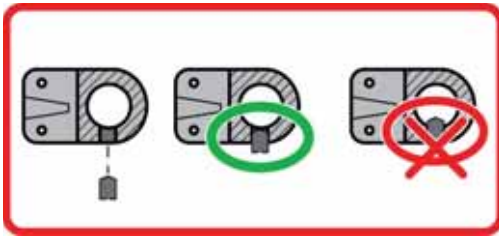



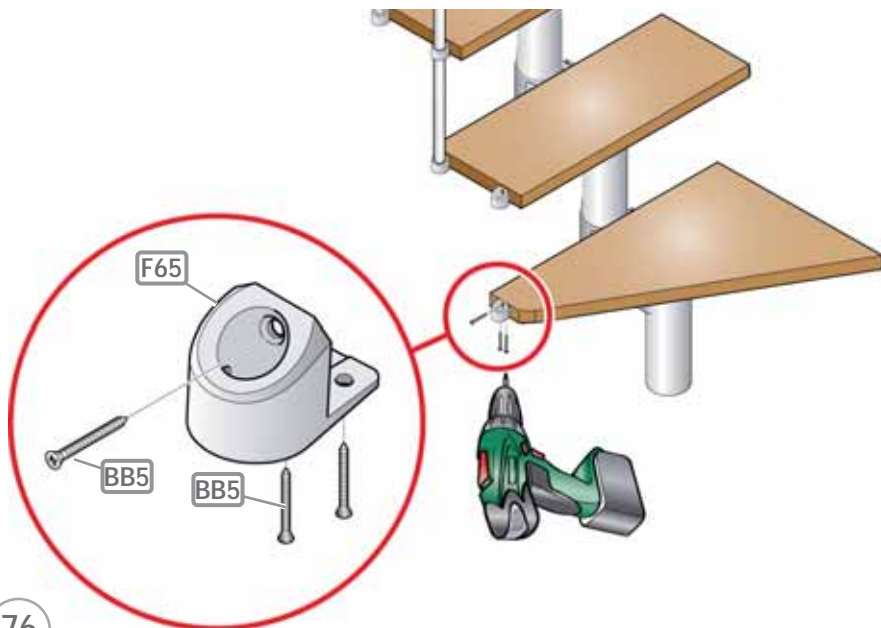

76

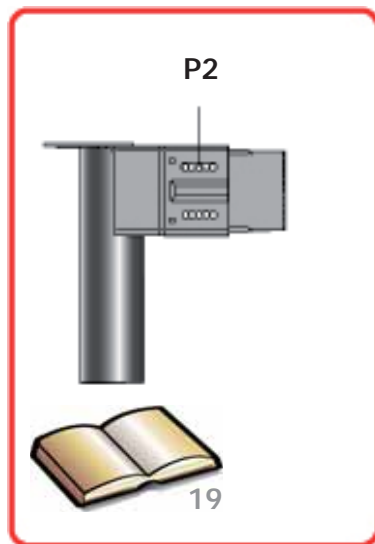
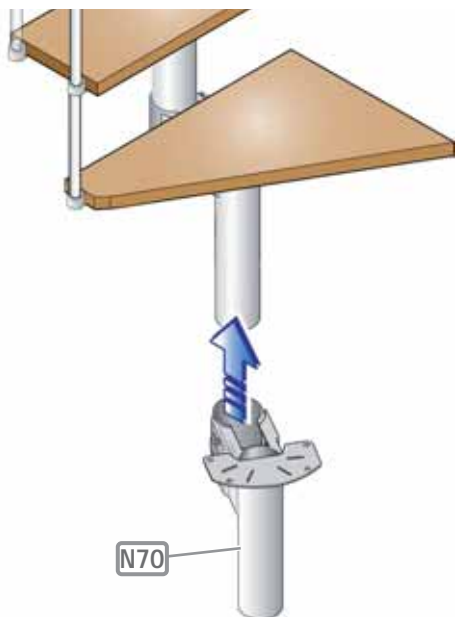

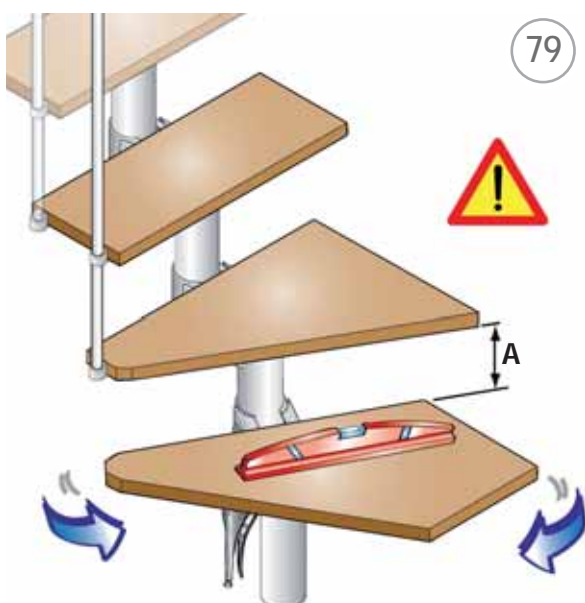
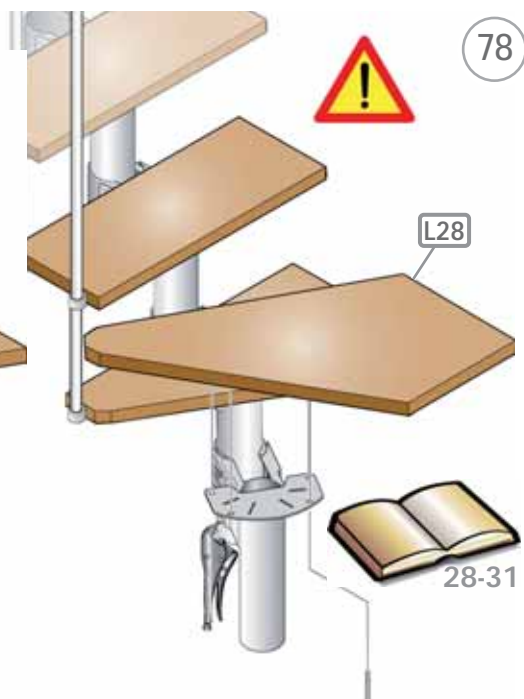
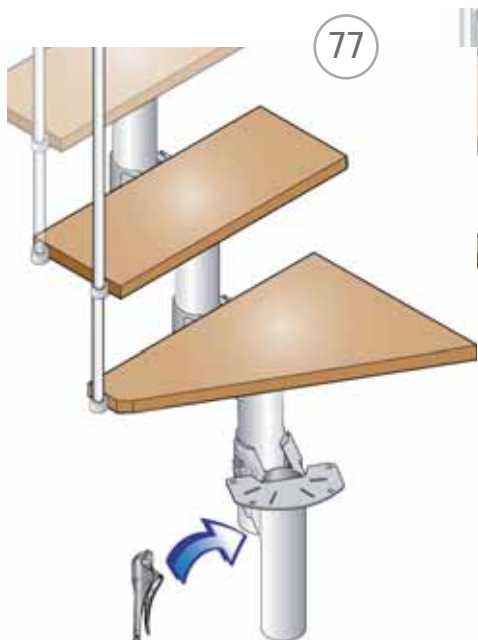

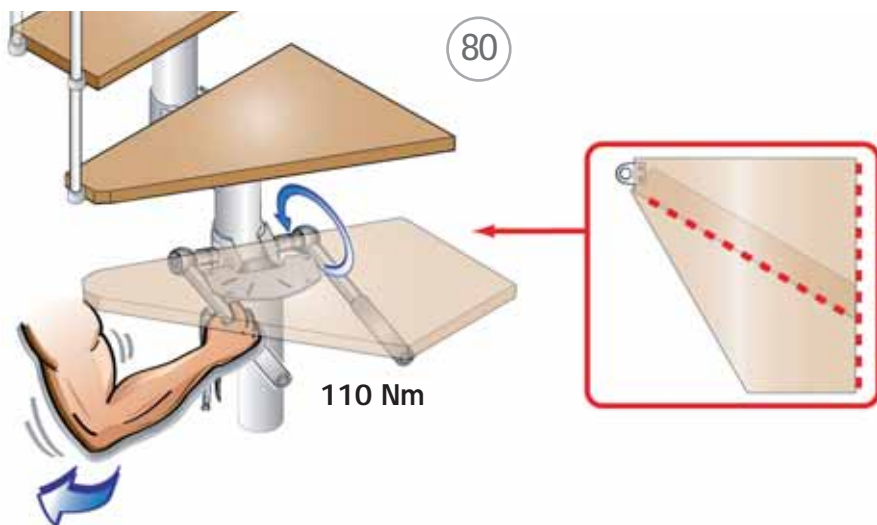

81

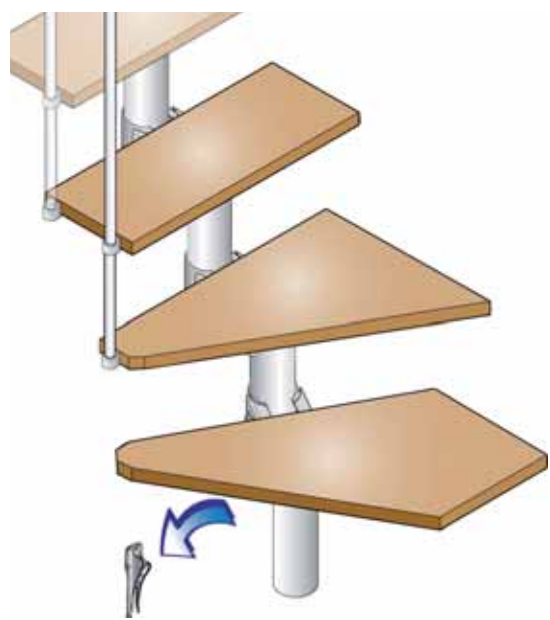
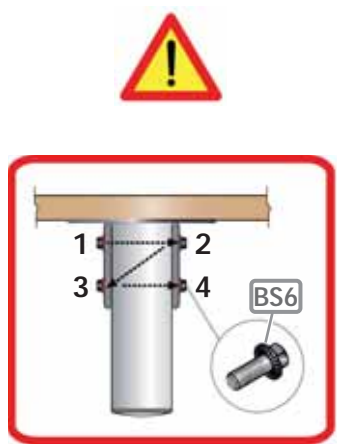

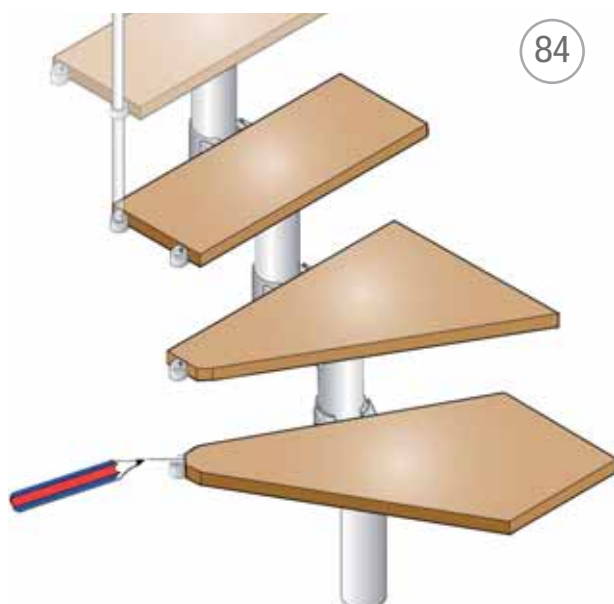
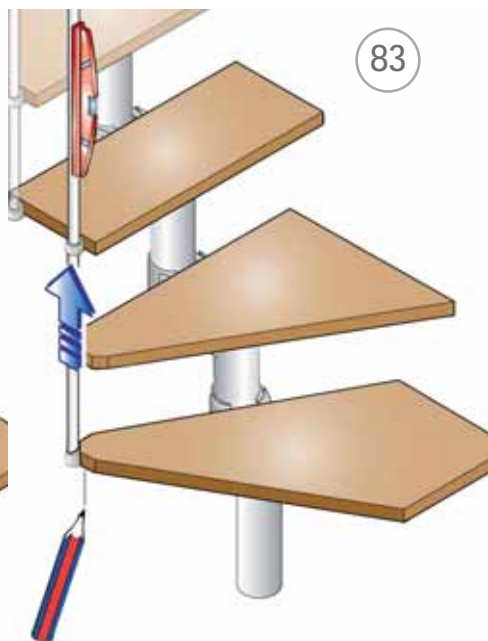
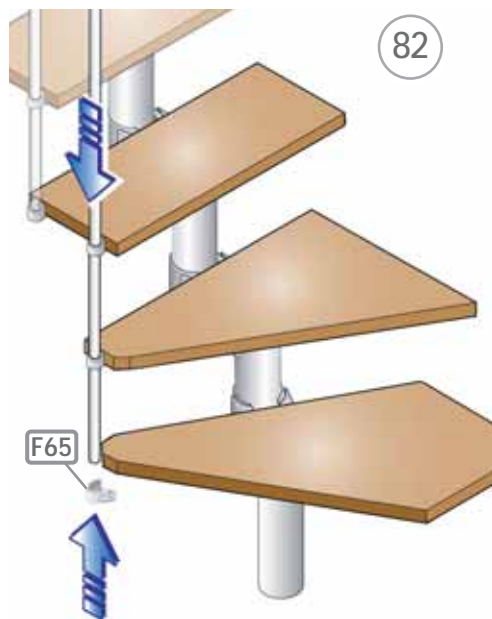

85

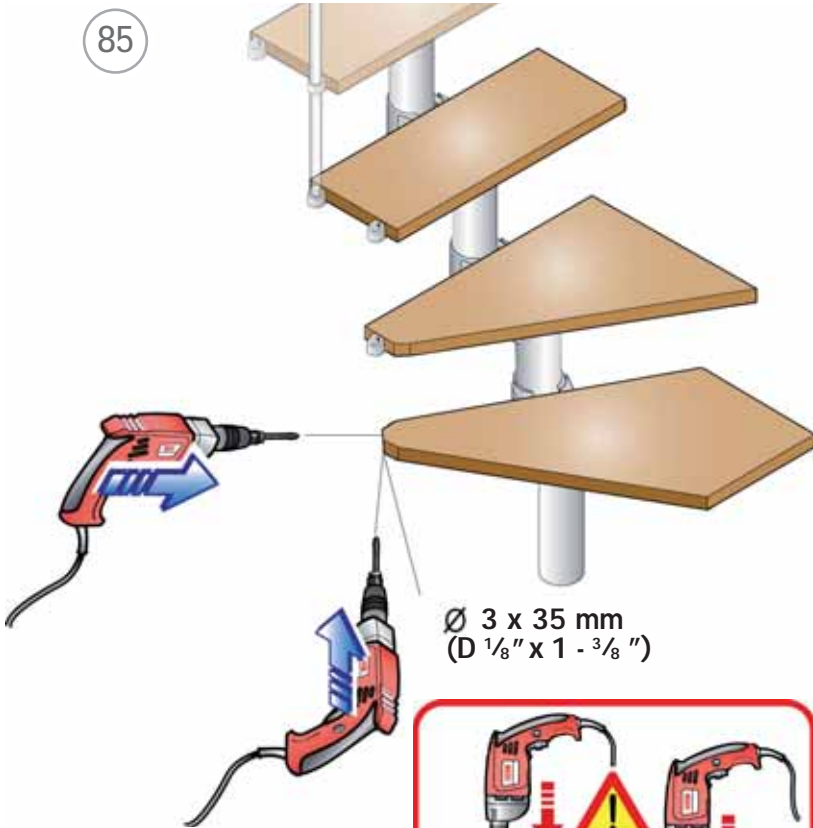

Ø 3 x 35 mm  
(D 1/8" x 1 - 3/8")

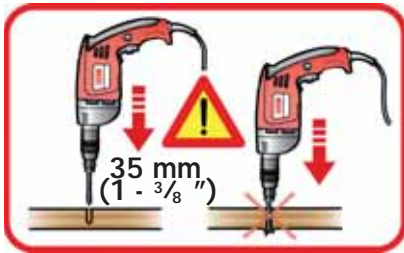

35 mm  
(1 - 3/8")

86

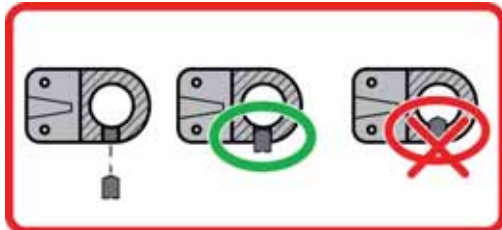

87

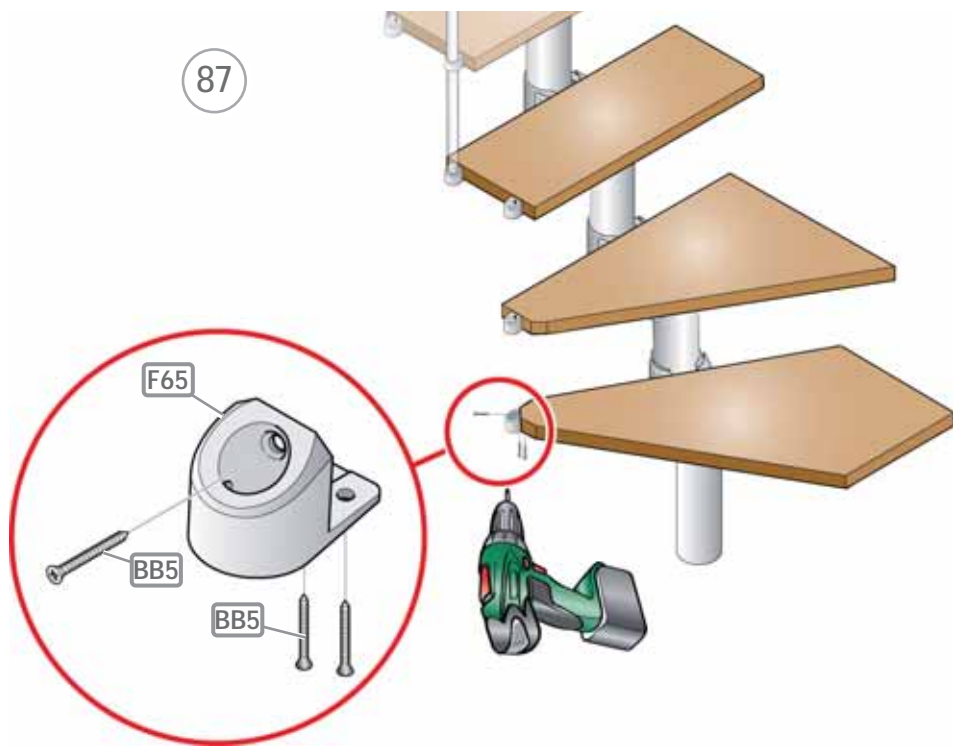

88

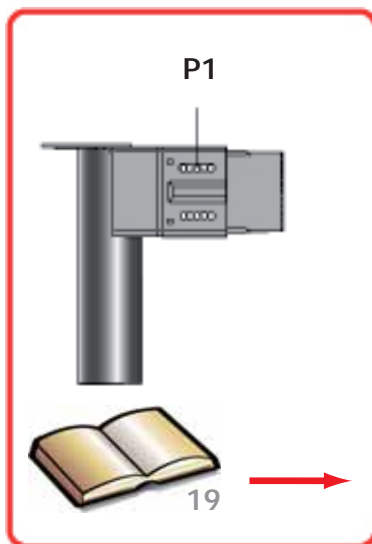
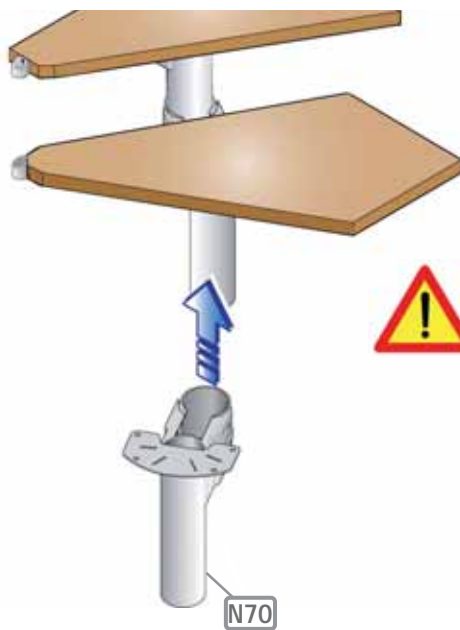

89

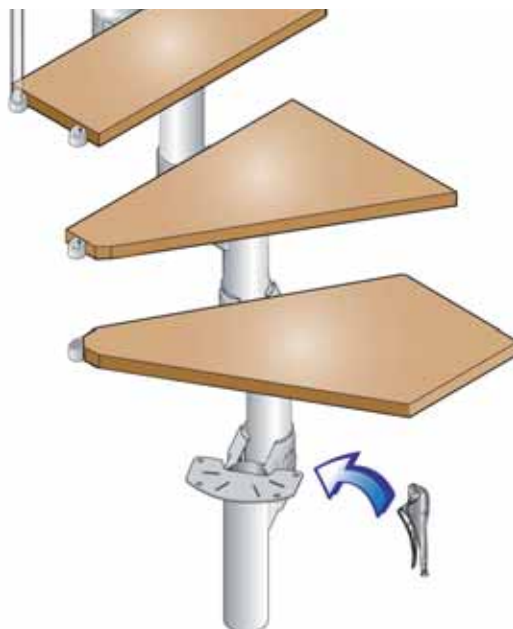

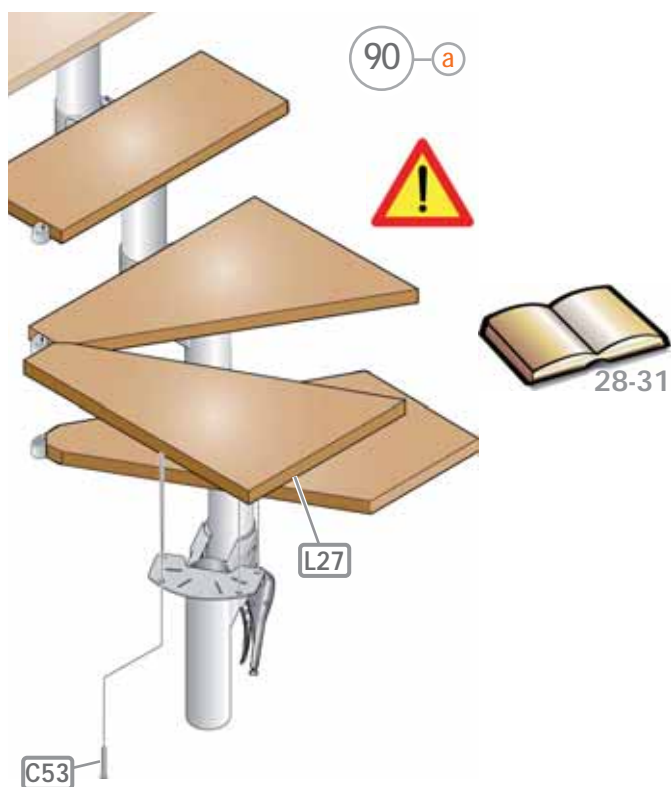
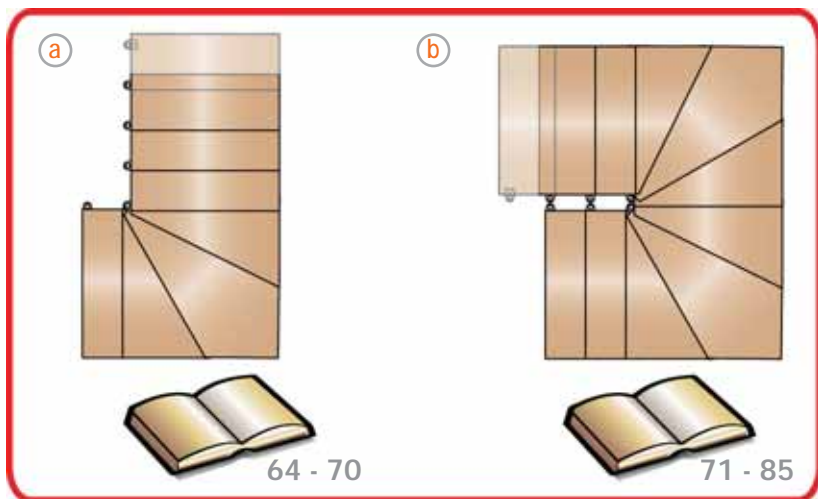



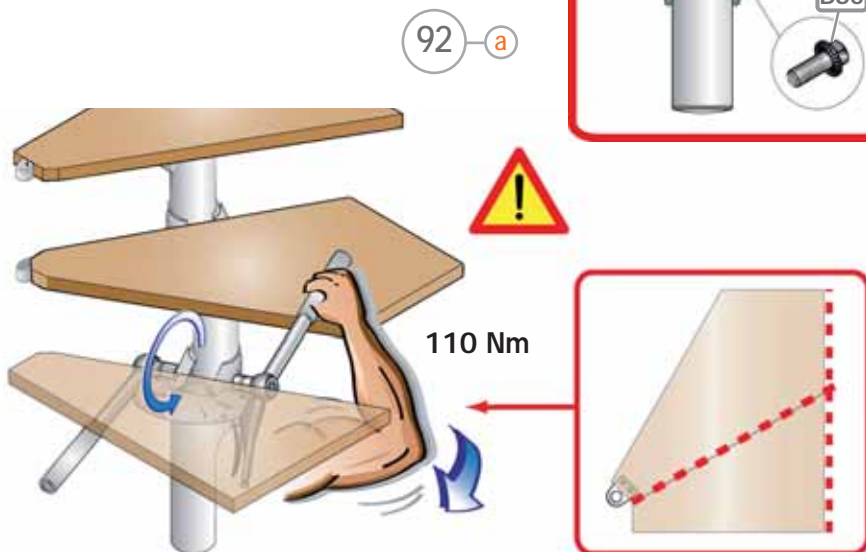
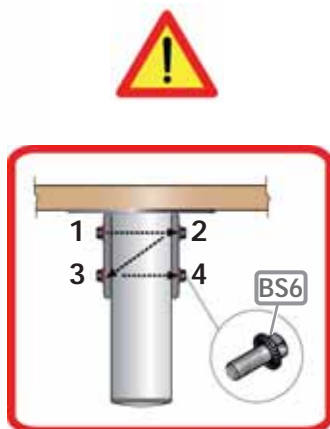
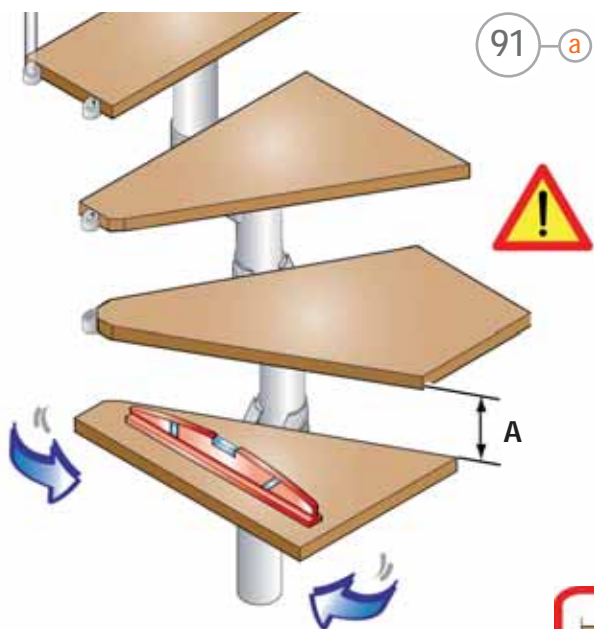

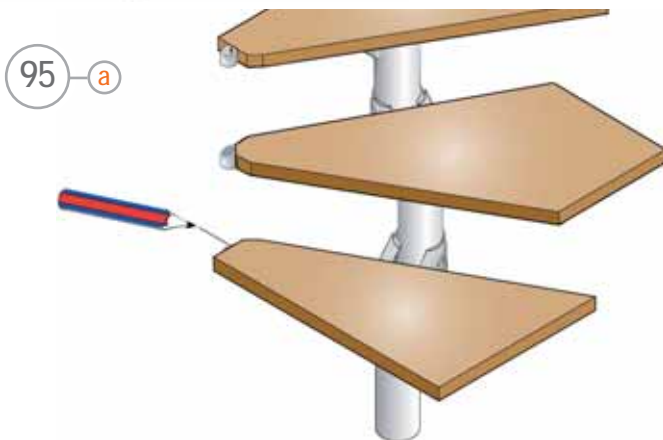
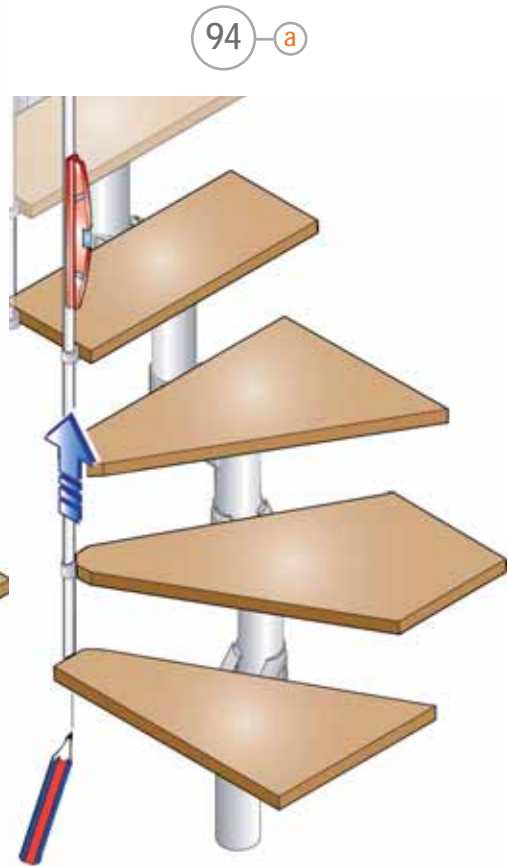
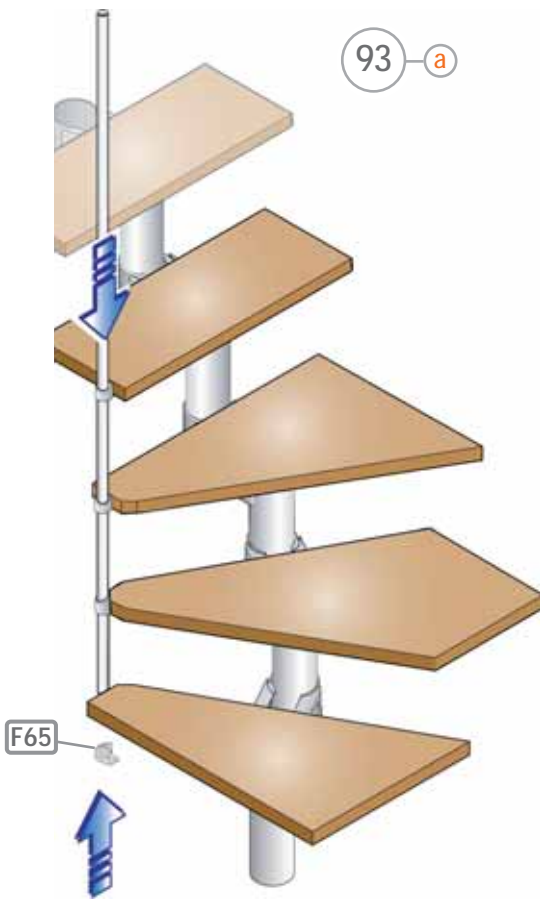

96 a

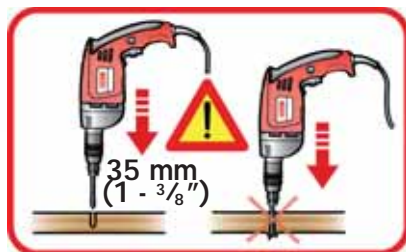
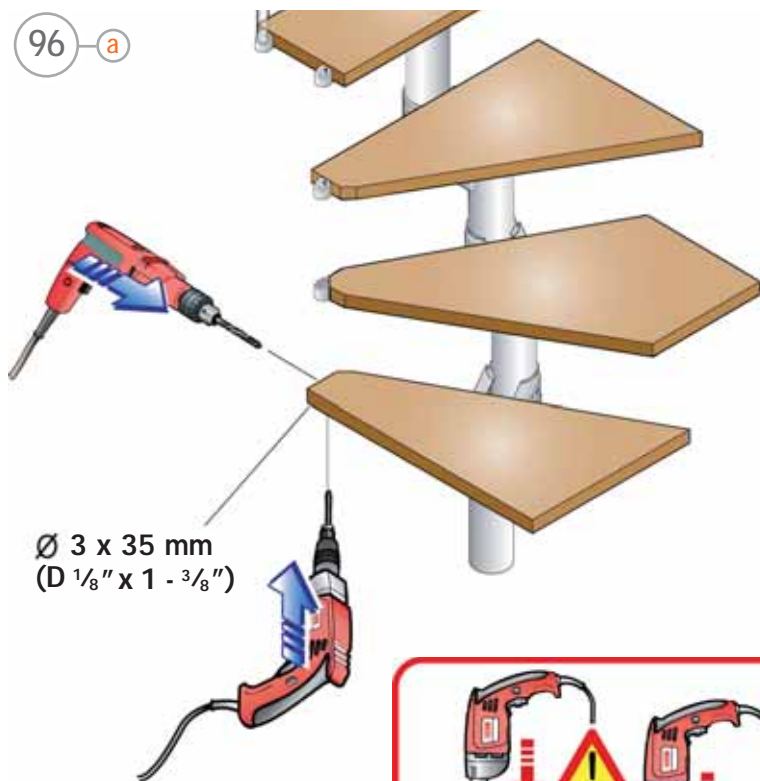

97 a

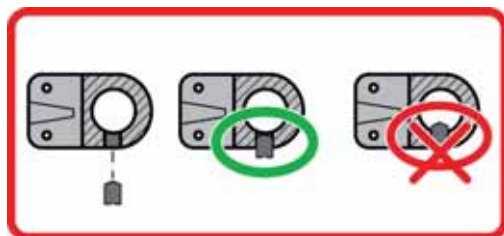

98 a

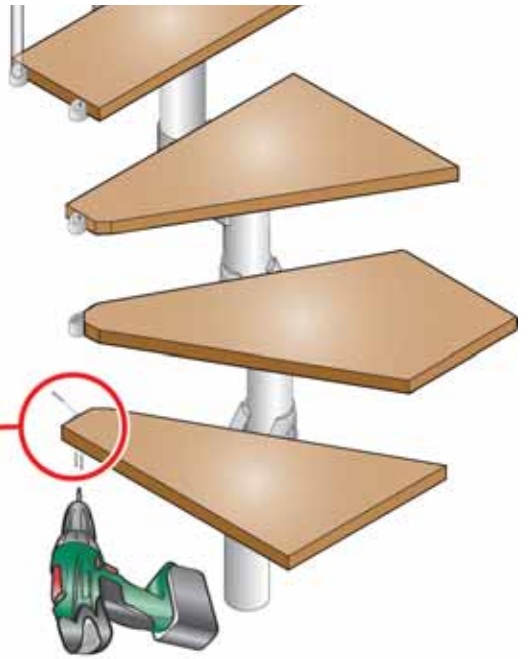
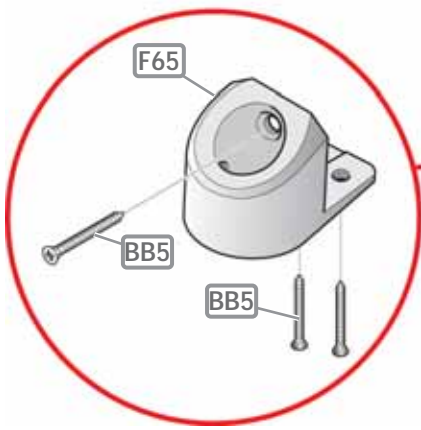

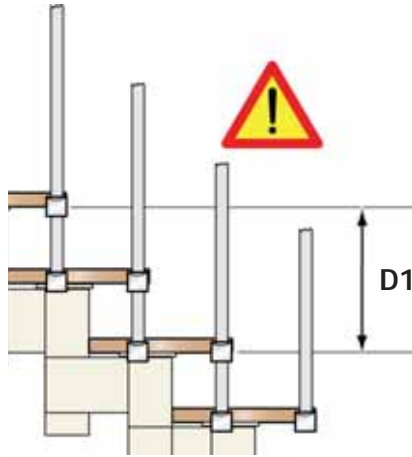

99 a

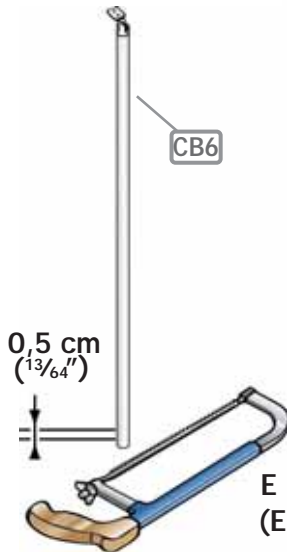

$$E = D1 + 0,5 \text{ cm}$$

$$(E = D1 + 13/64'')$$

100 a

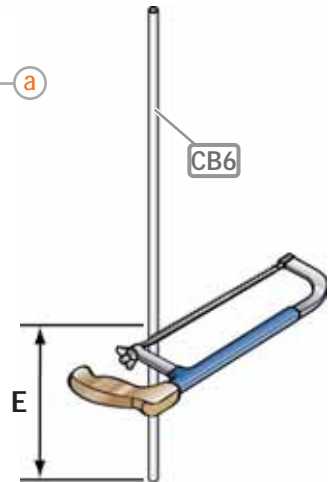

101 a



102 a

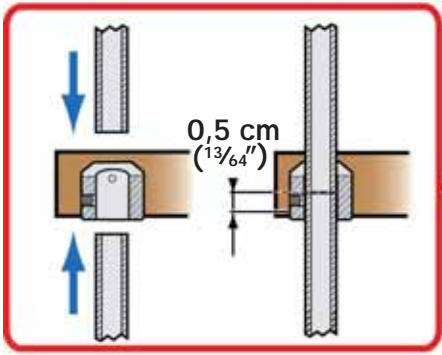
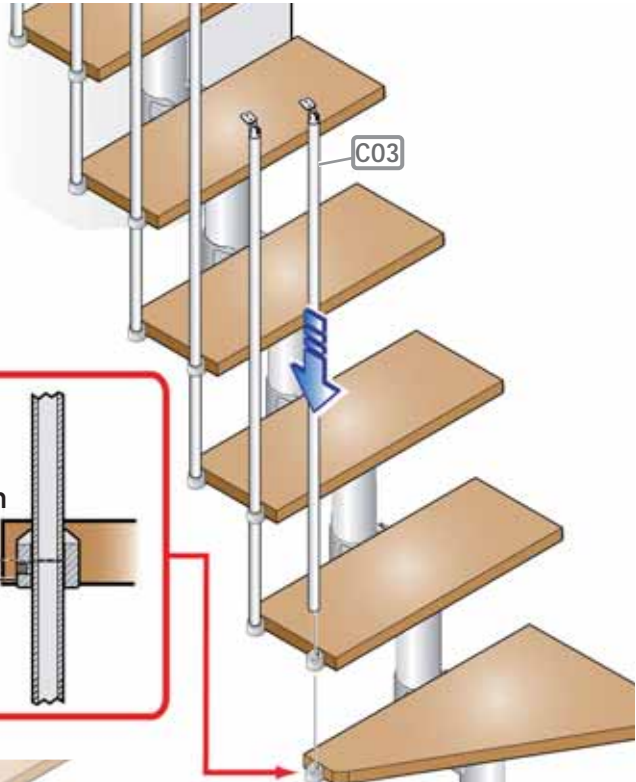

103

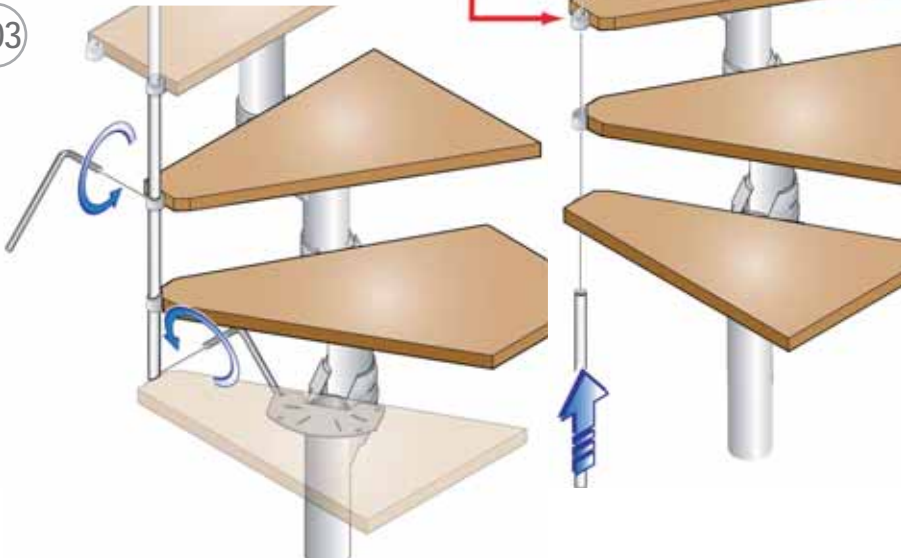

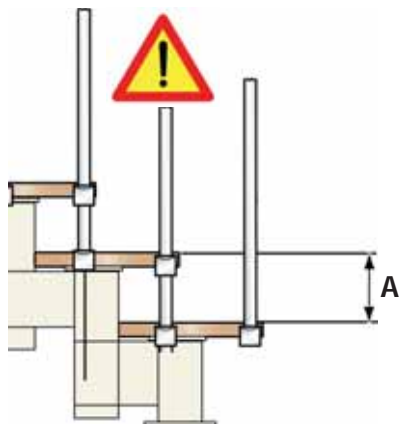
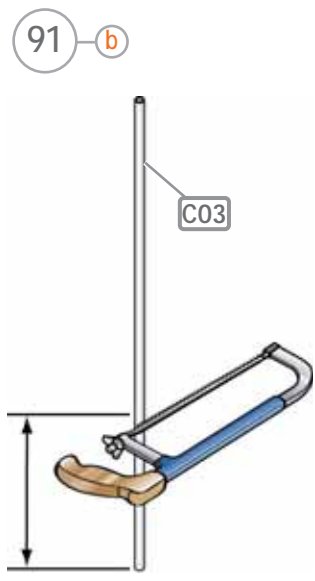
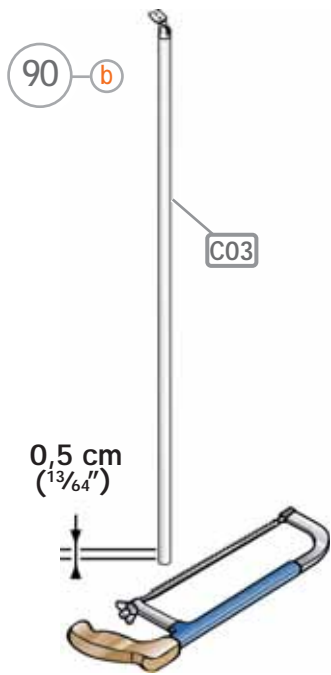

$$F = A + 0,5 \text{ cm} \\ (A + \frac{13}{64} \text{ inches})$$

93 b

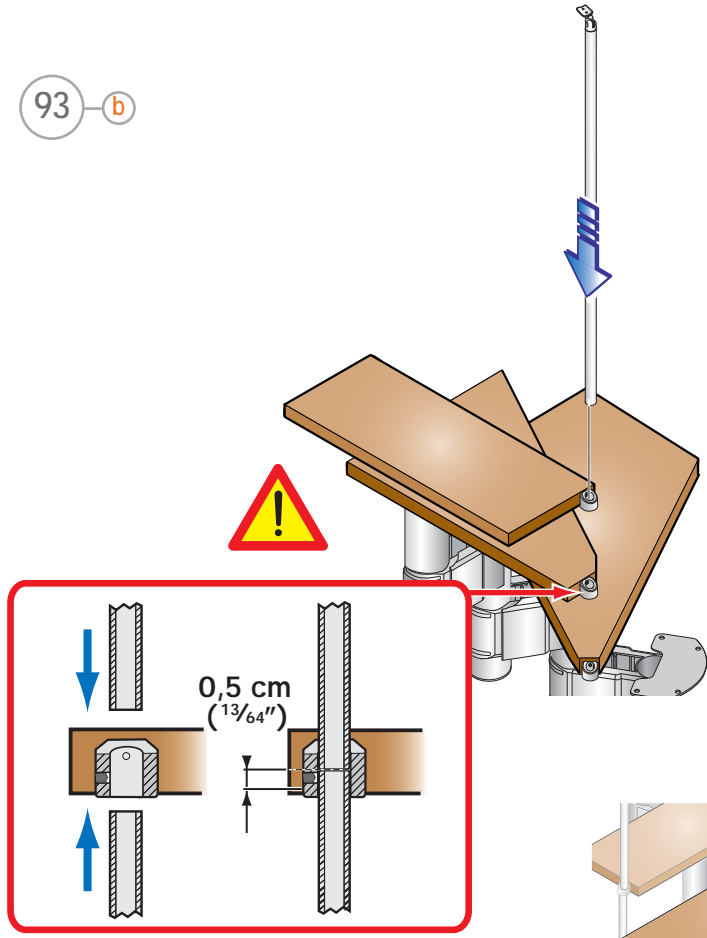

94 b

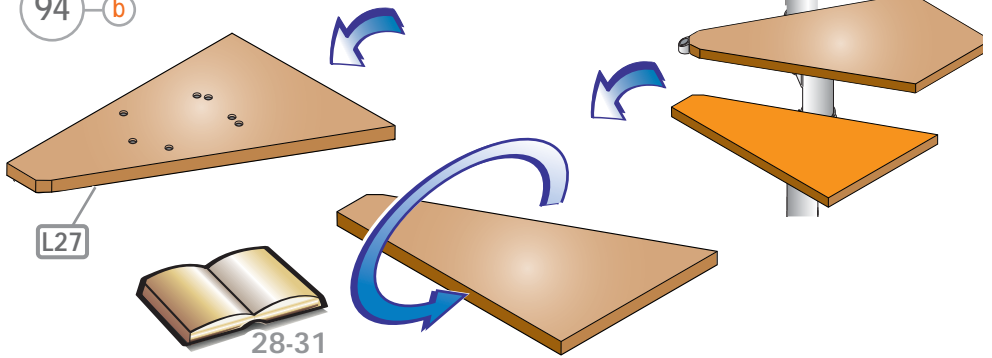



95 b

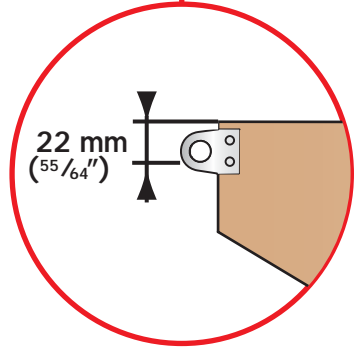
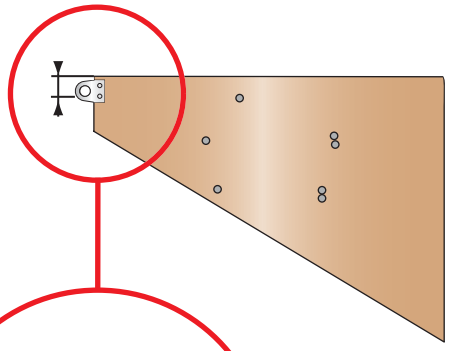
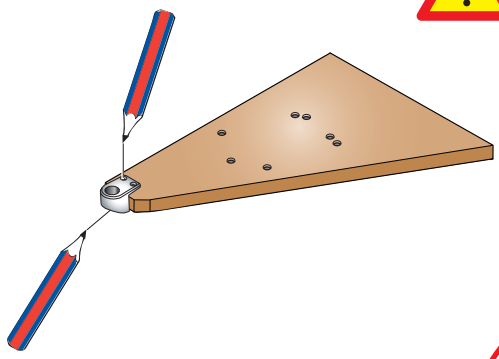

96 b

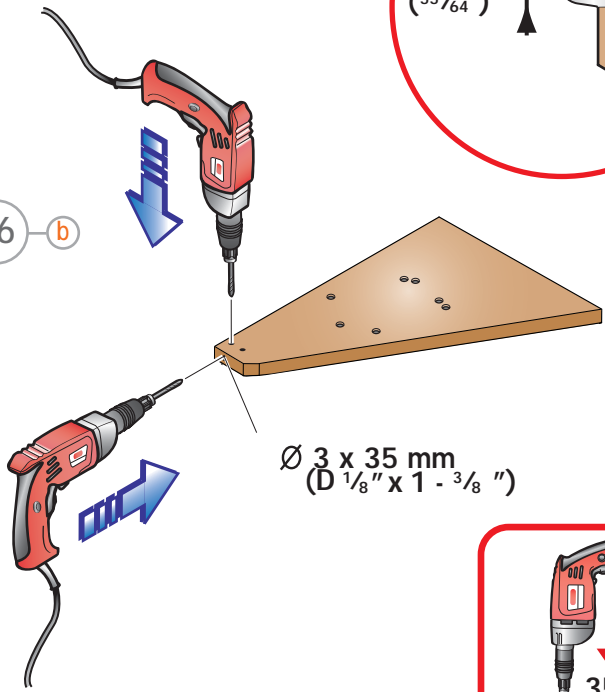

Ø 3 x 35 mm  
(D 1/8" x 1 - 3/8")

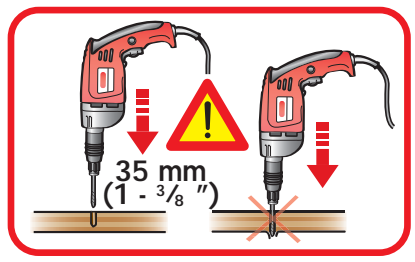

35 mm  
(1 - 3/8")

97 **b**

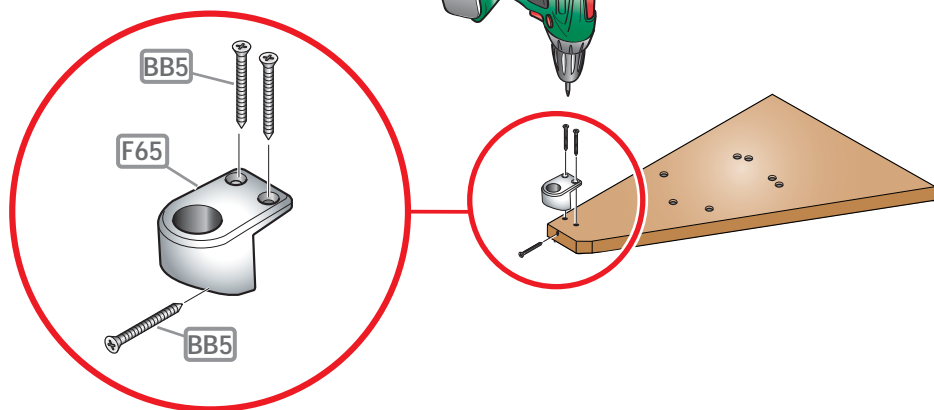

98 **b**

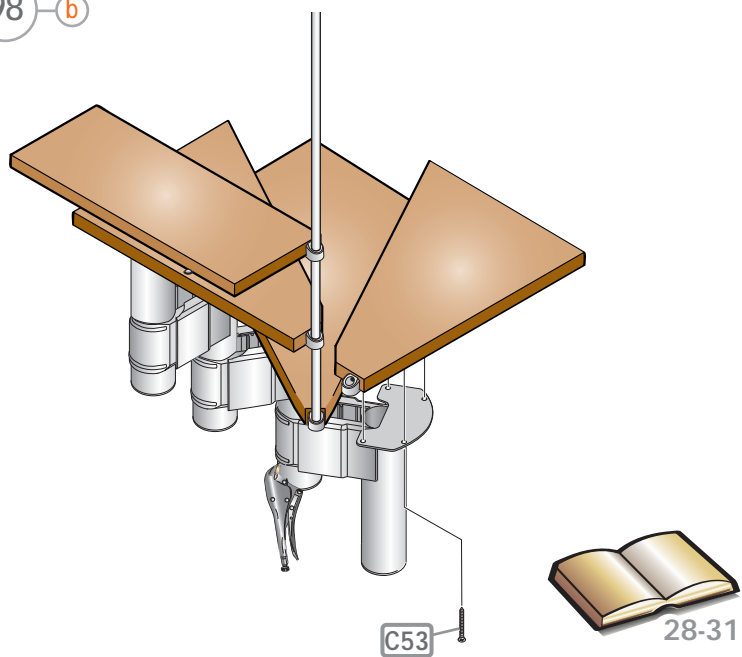

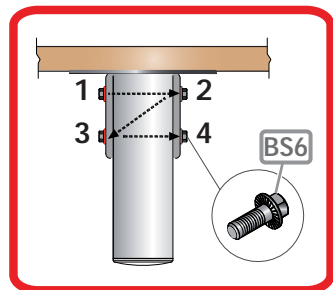
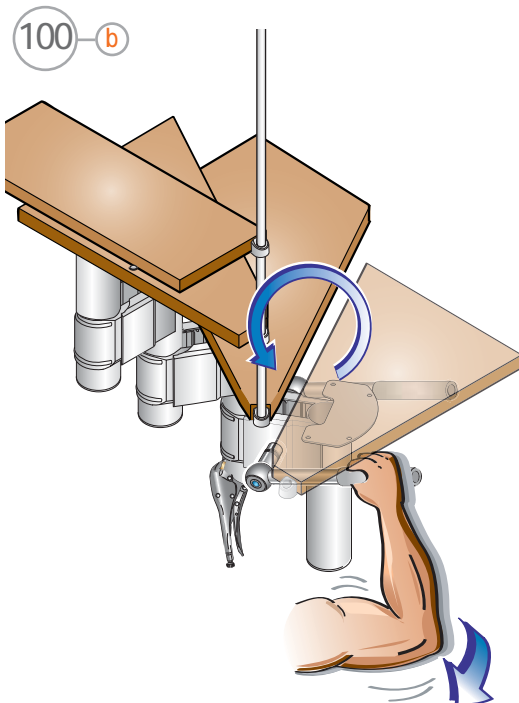
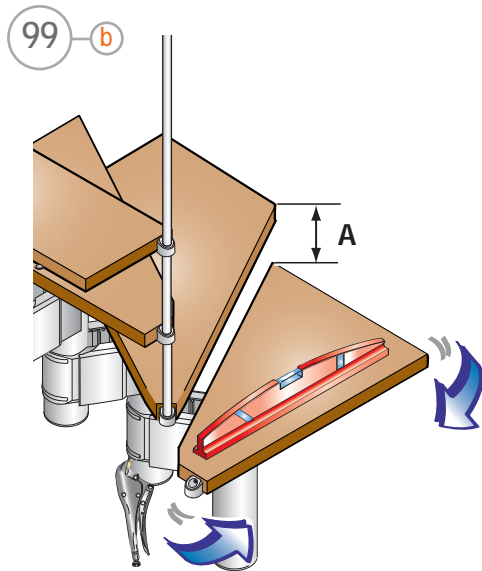

101 b

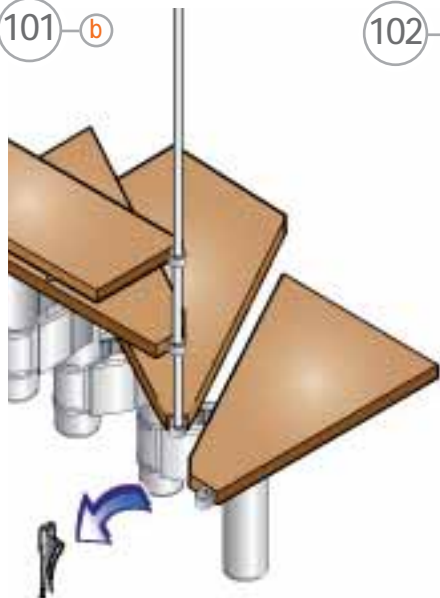

102 b

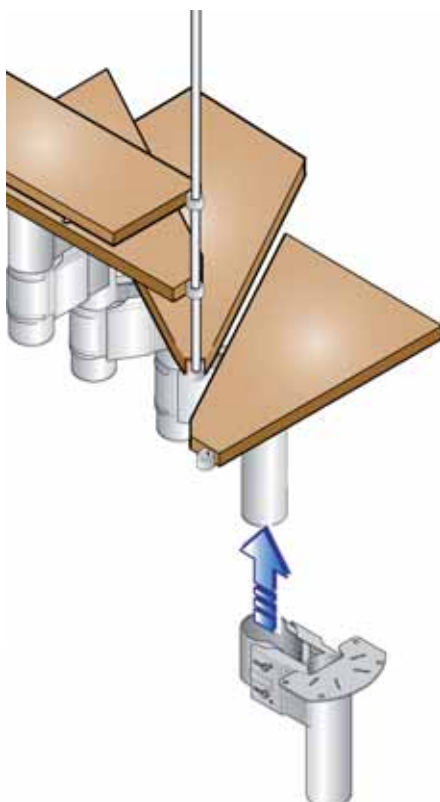

103 b

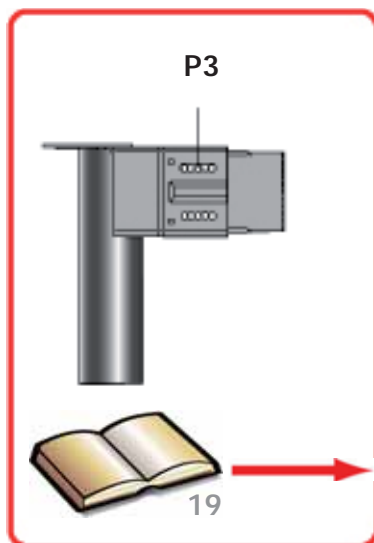
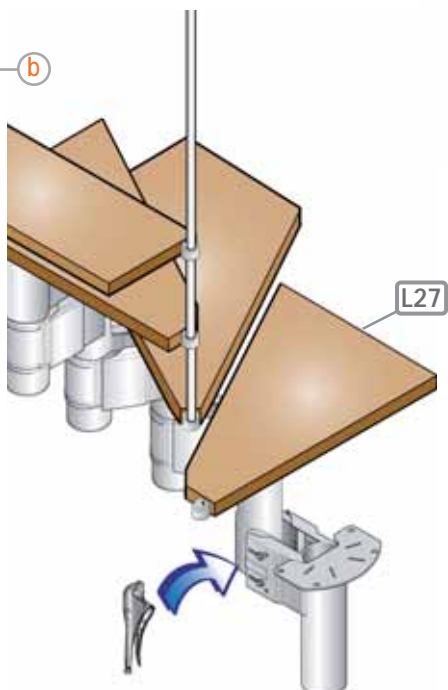

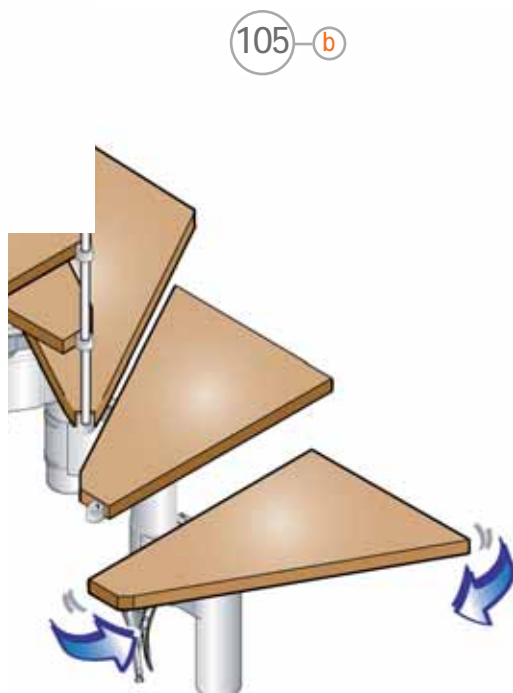
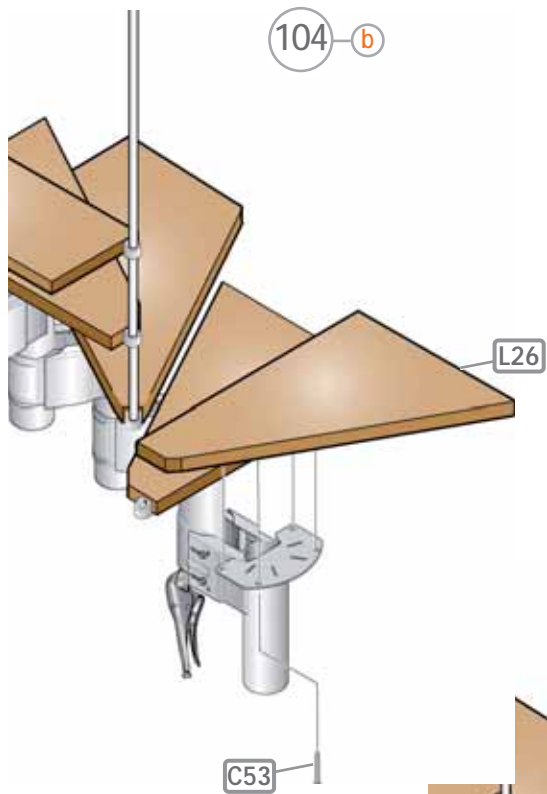

106 (b)

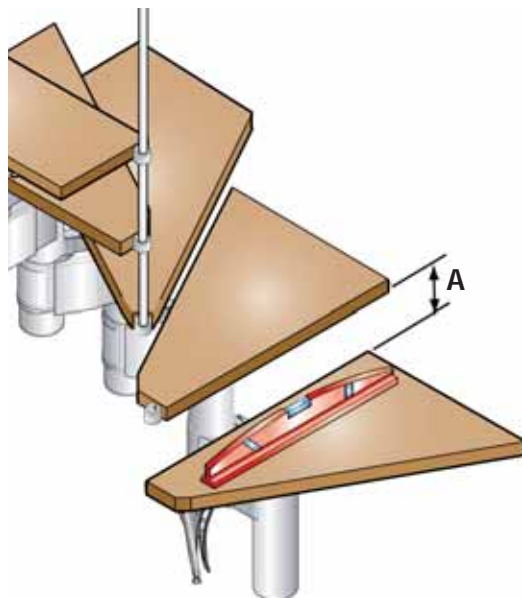

107 (b)

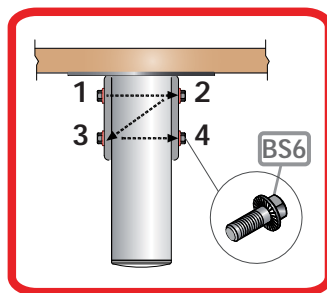
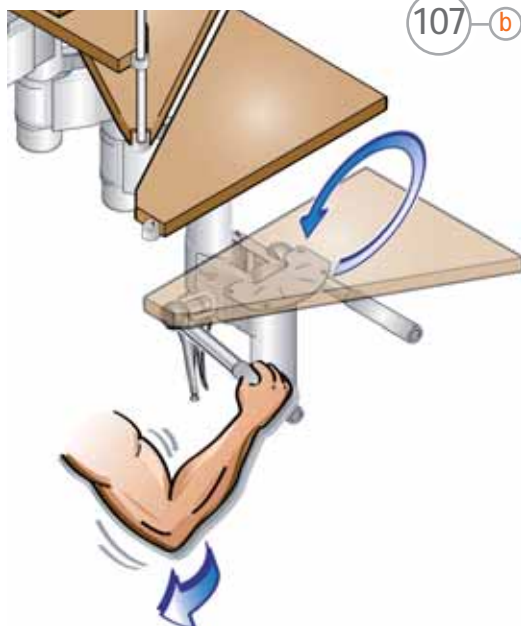

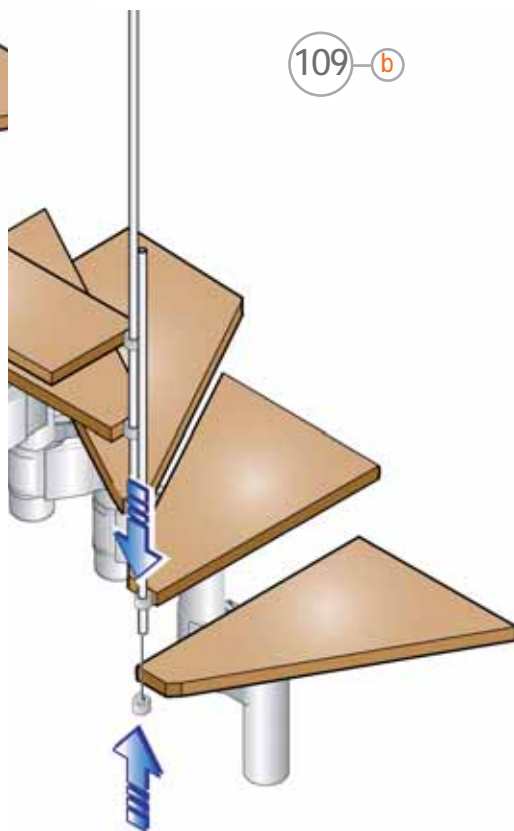
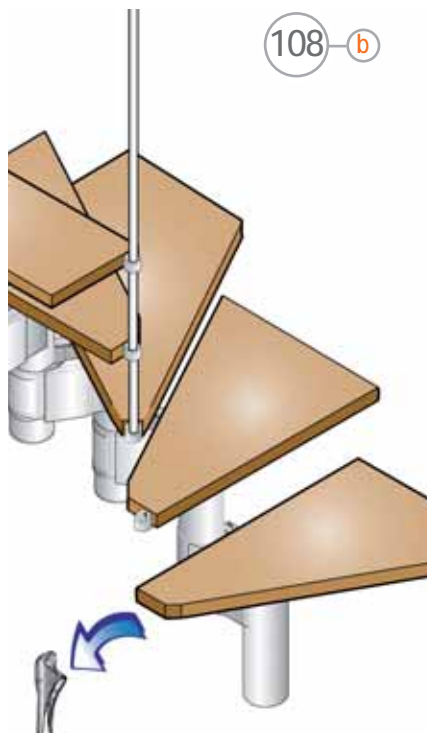

110 b

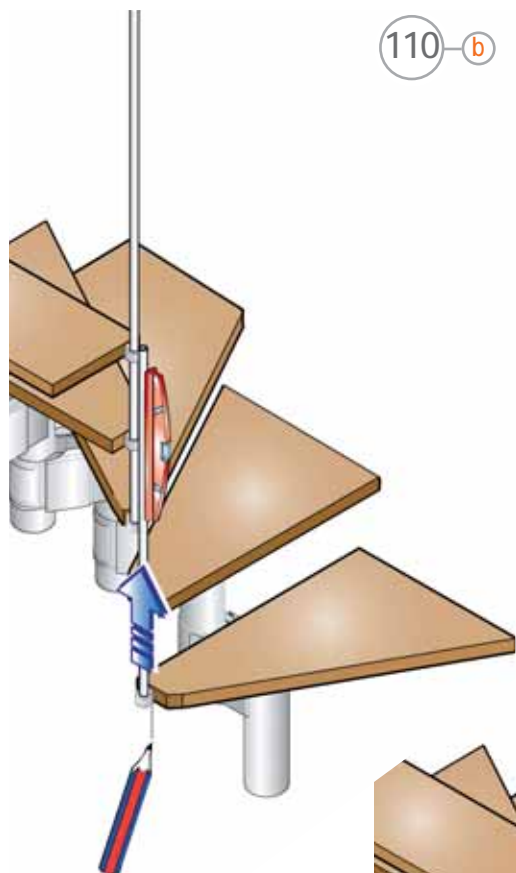

111 b

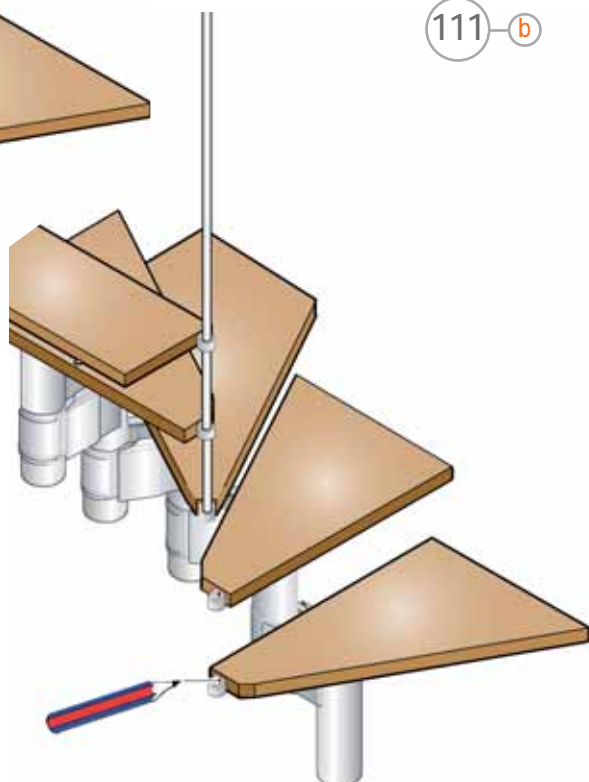



112—b

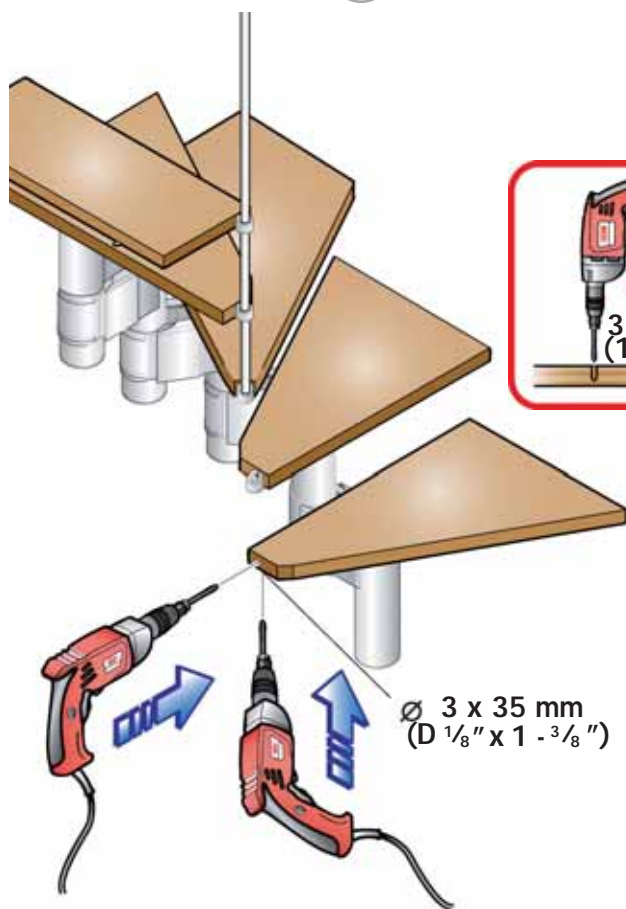

Ø 3 x 35 mm  
(D 1/8" x 1 - 3/8")

113 b

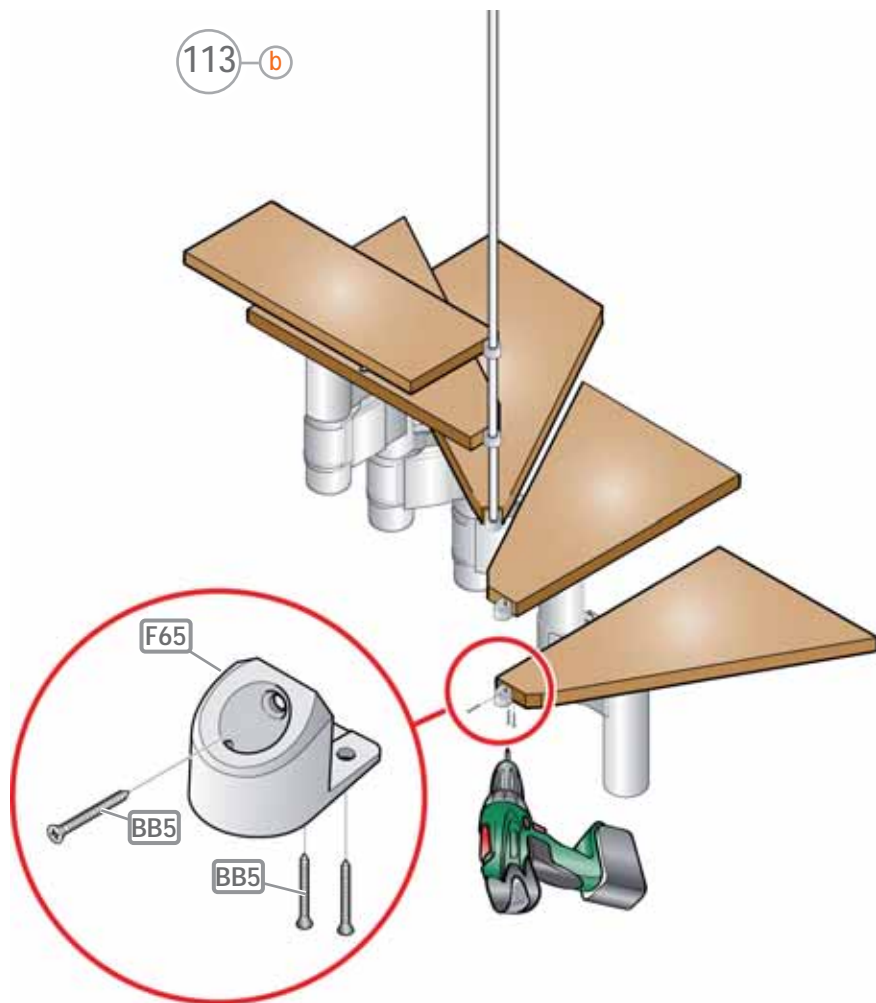

114 b

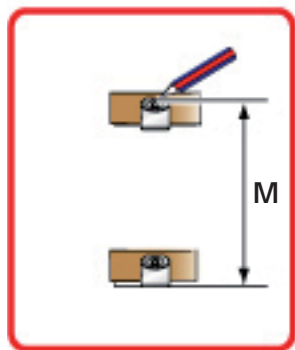
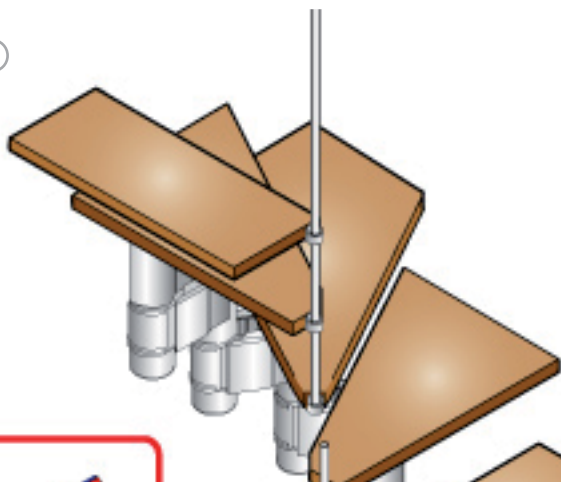

116 b

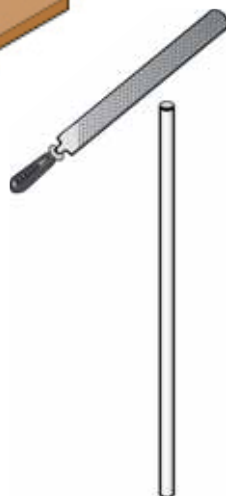

115 b

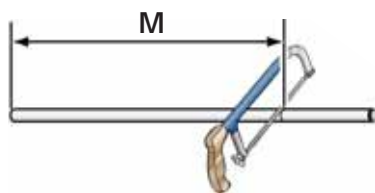

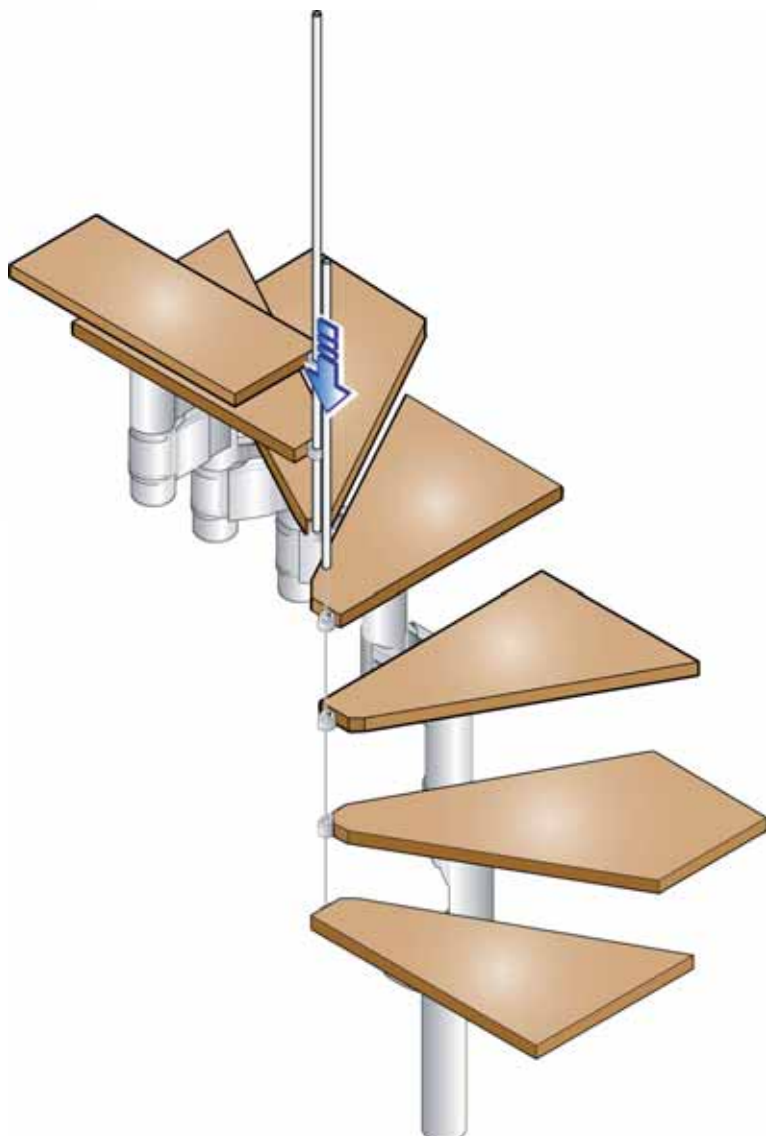

119 b

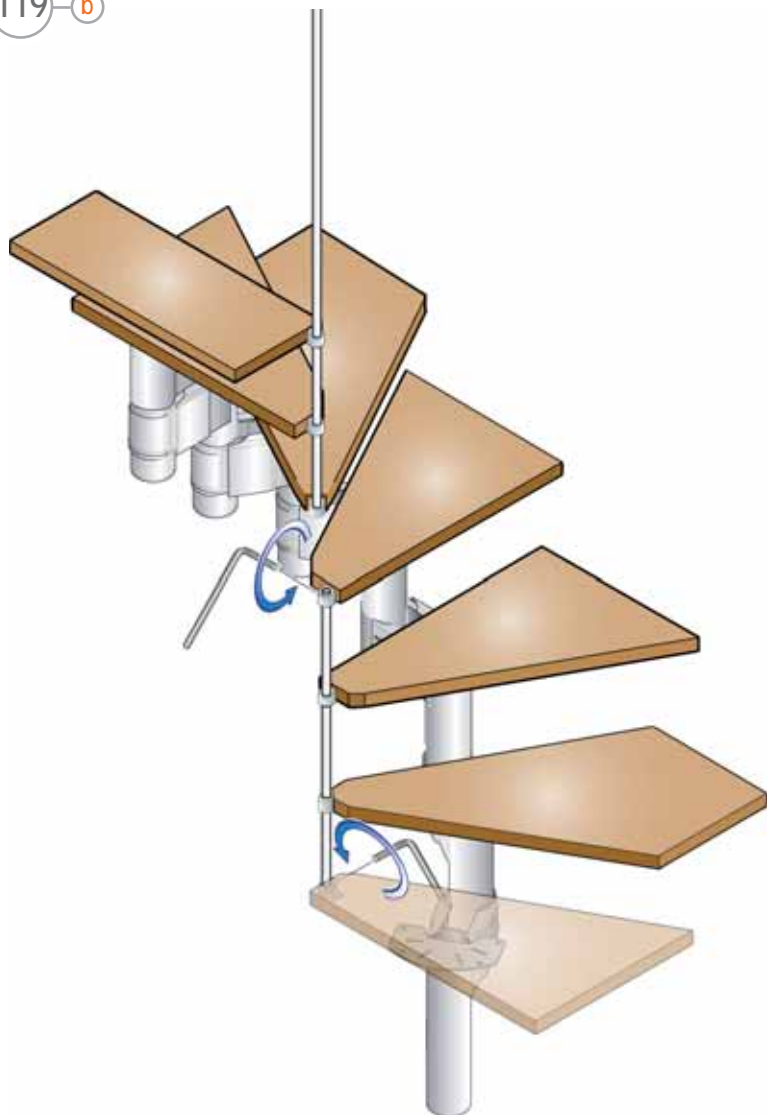

120

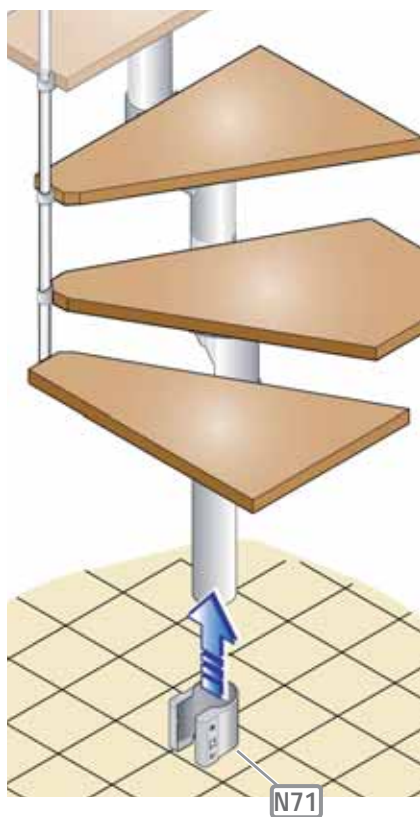

121

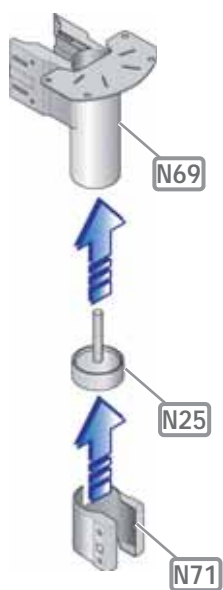

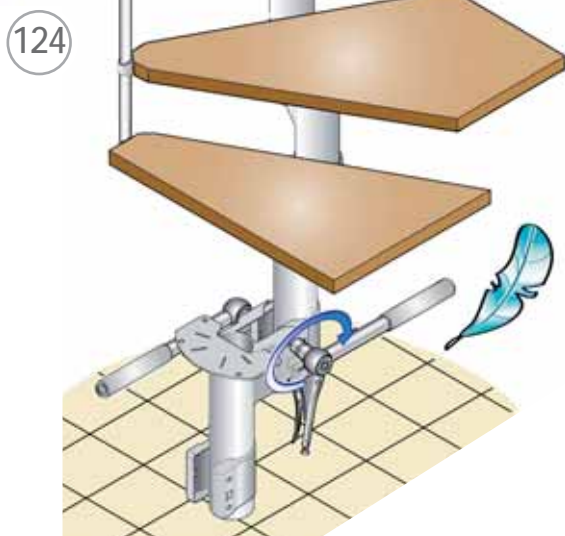
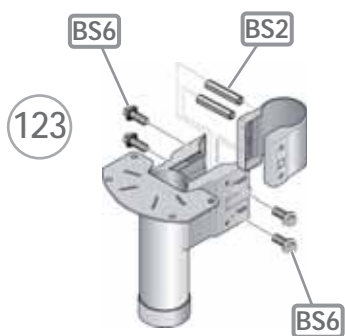
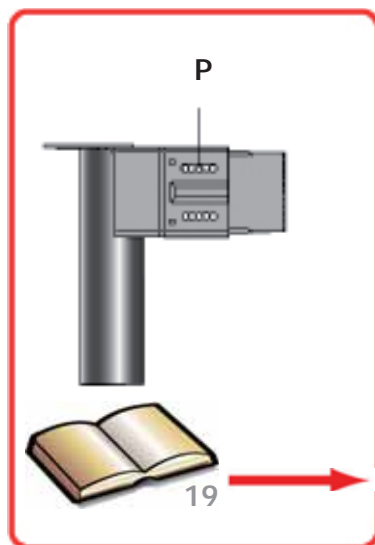
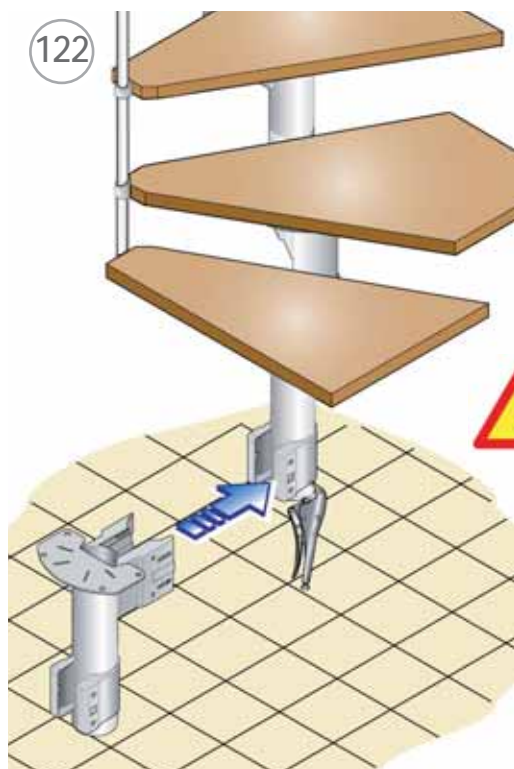

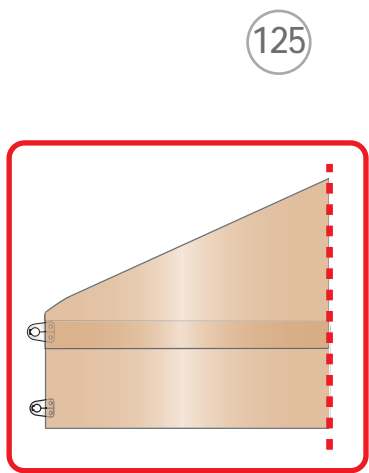
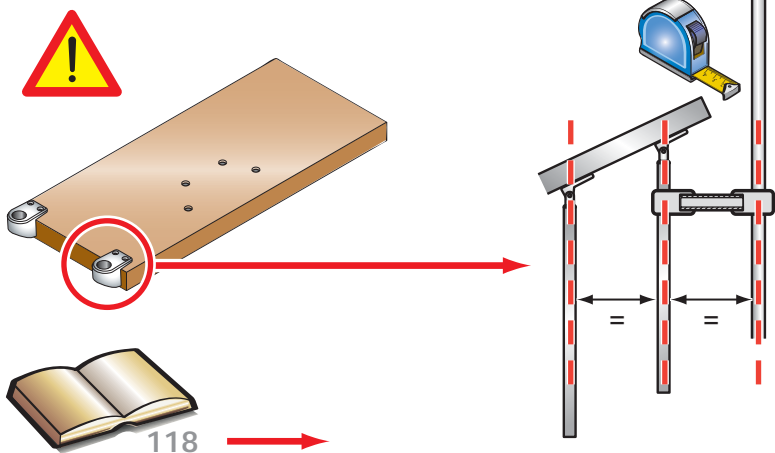

125

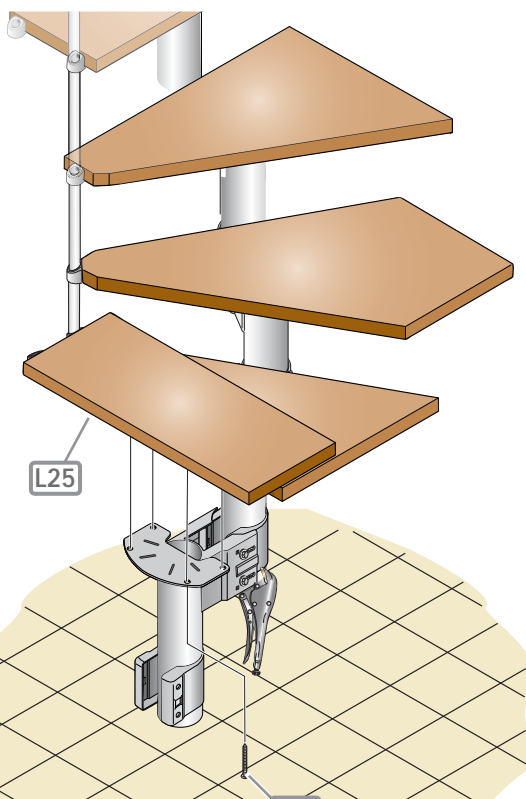



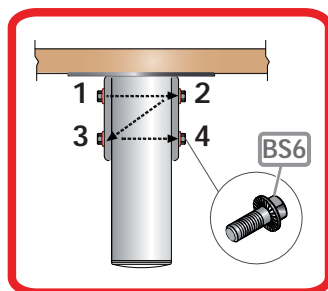
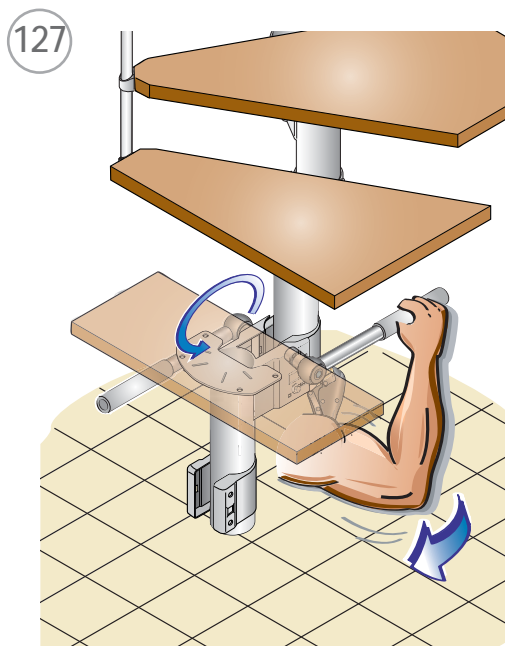
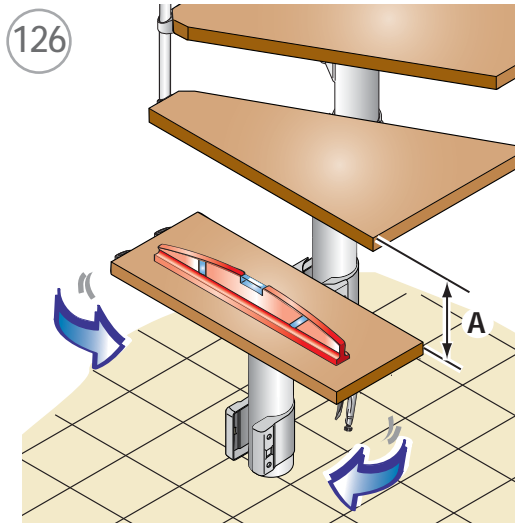

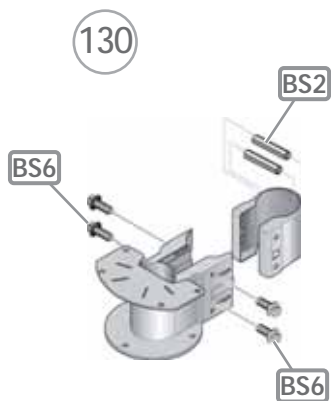
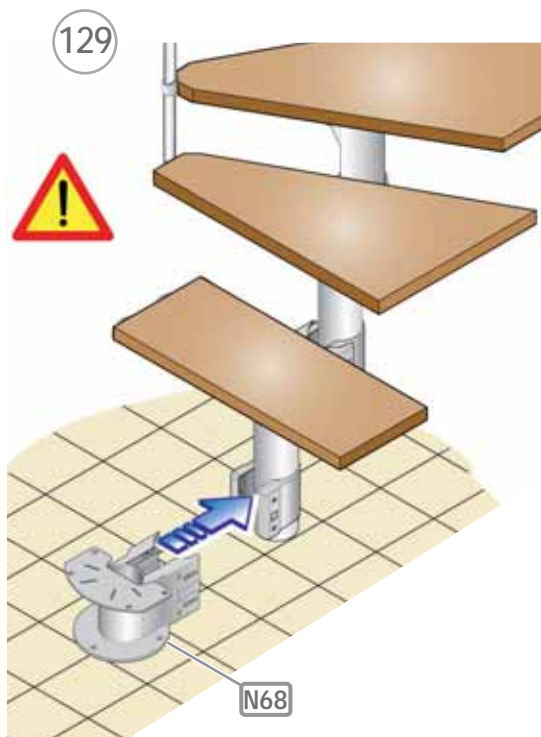
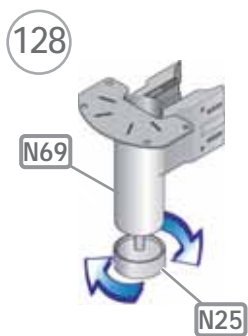
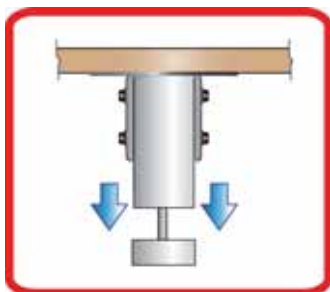

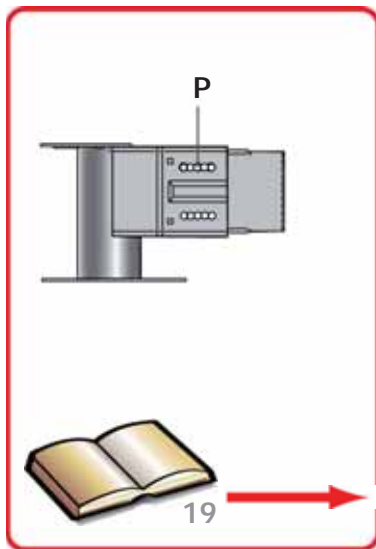

131

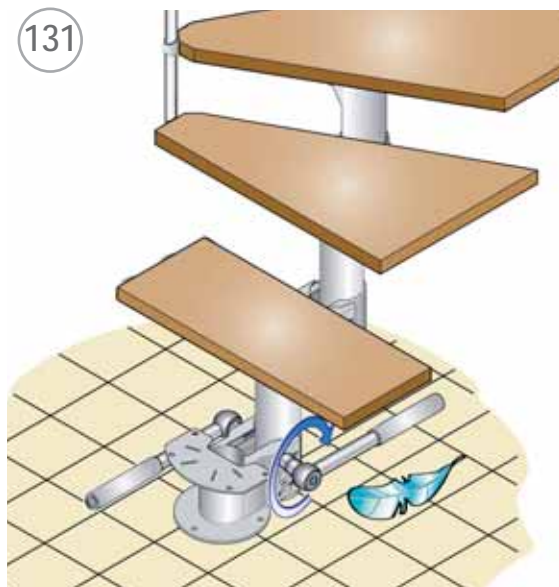

132

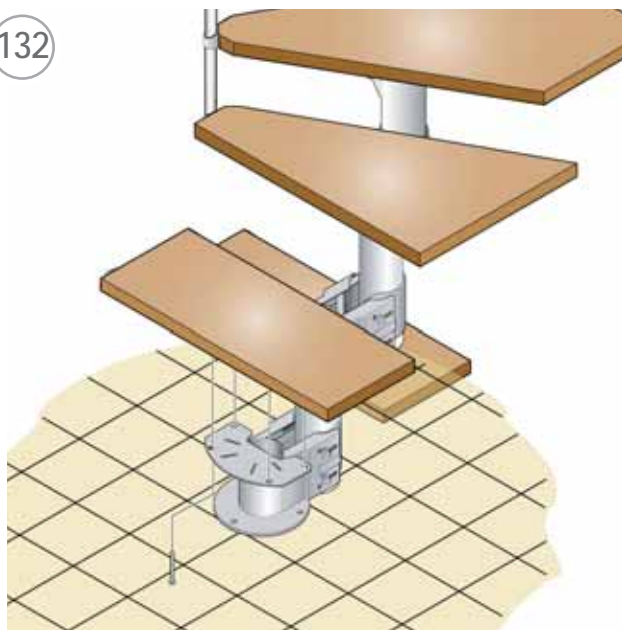

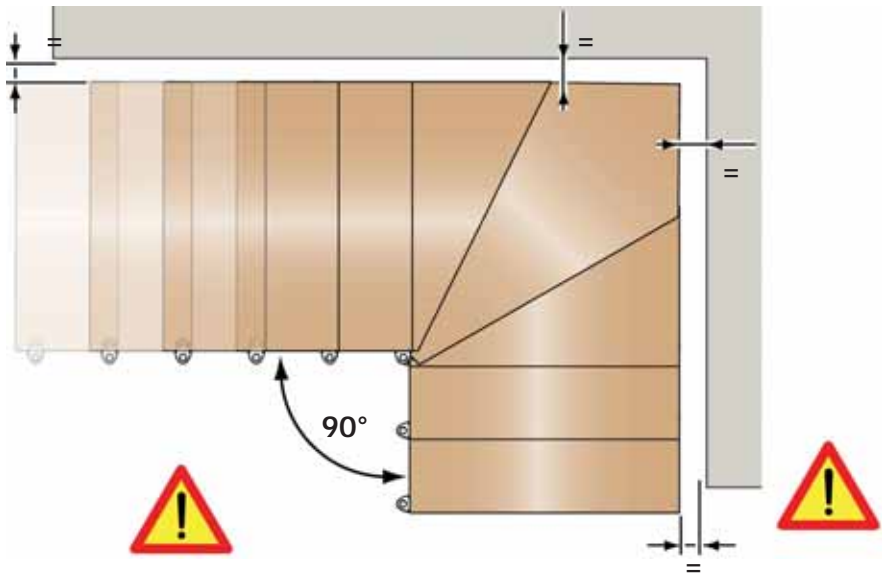

133

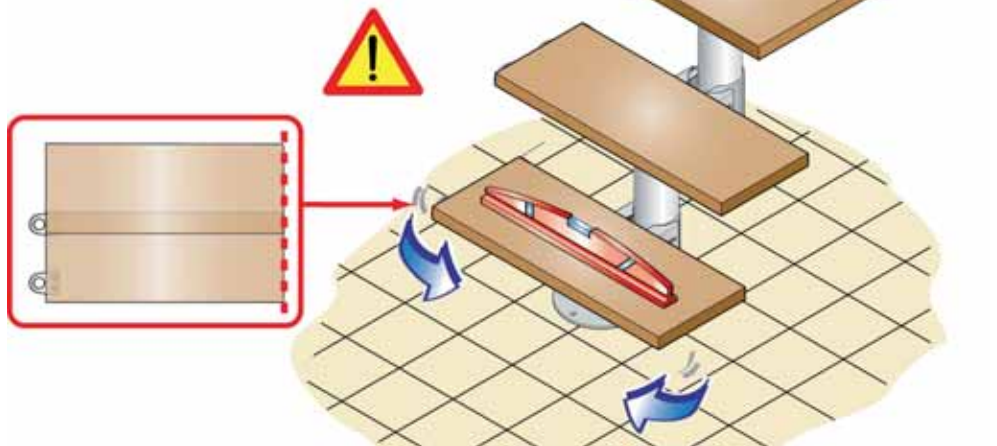

134

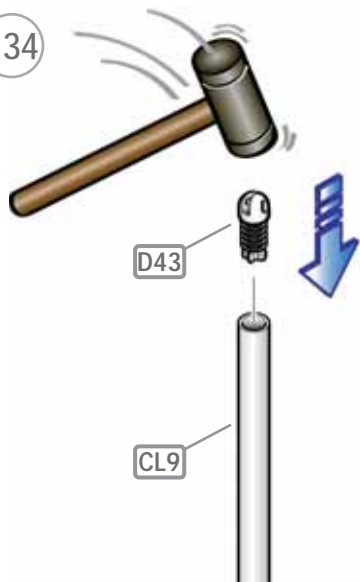

135

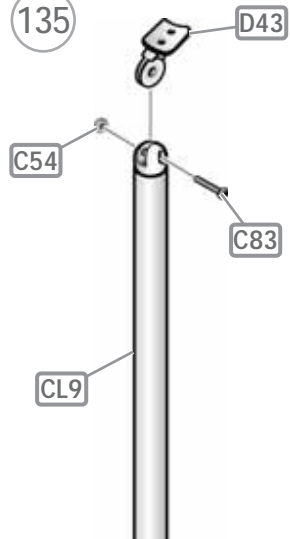

136

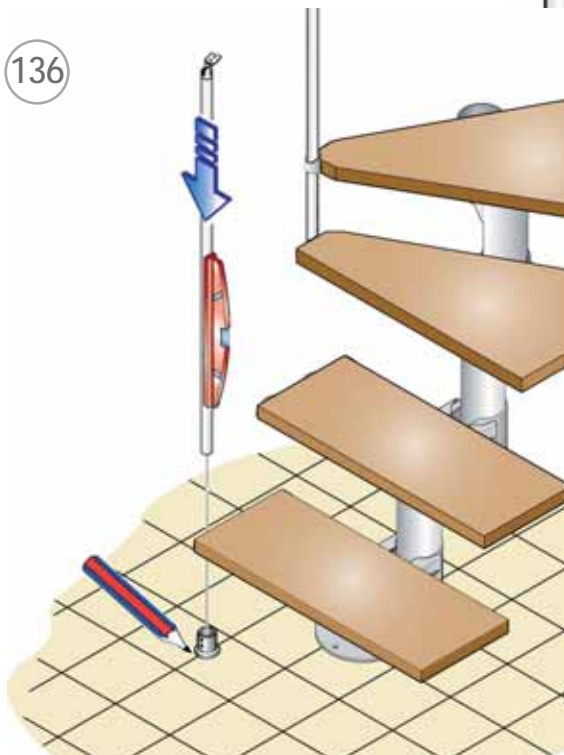

137

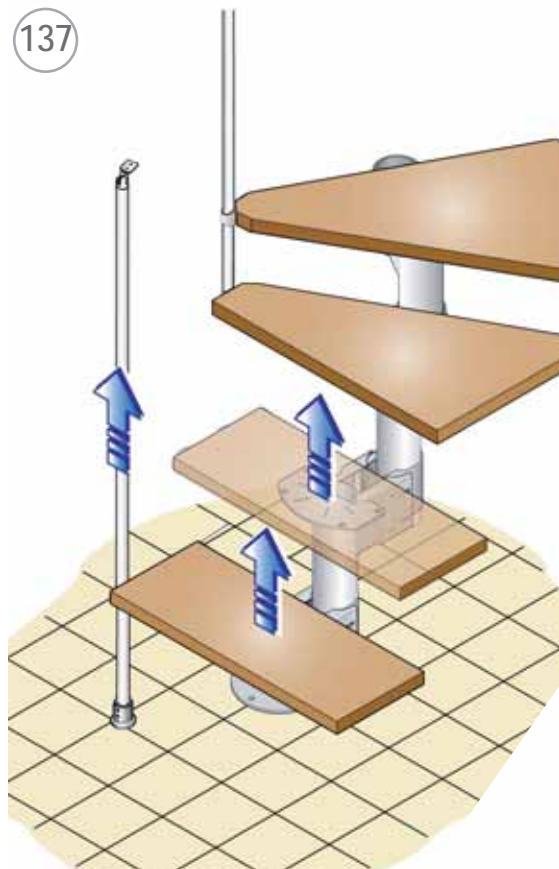

138

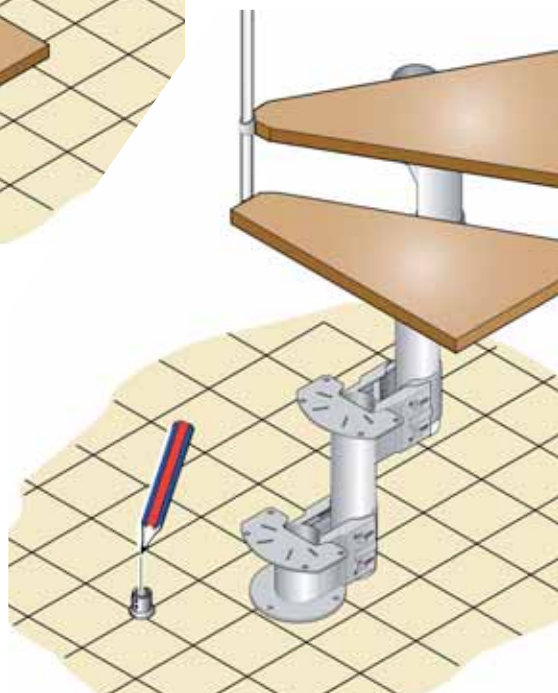

139

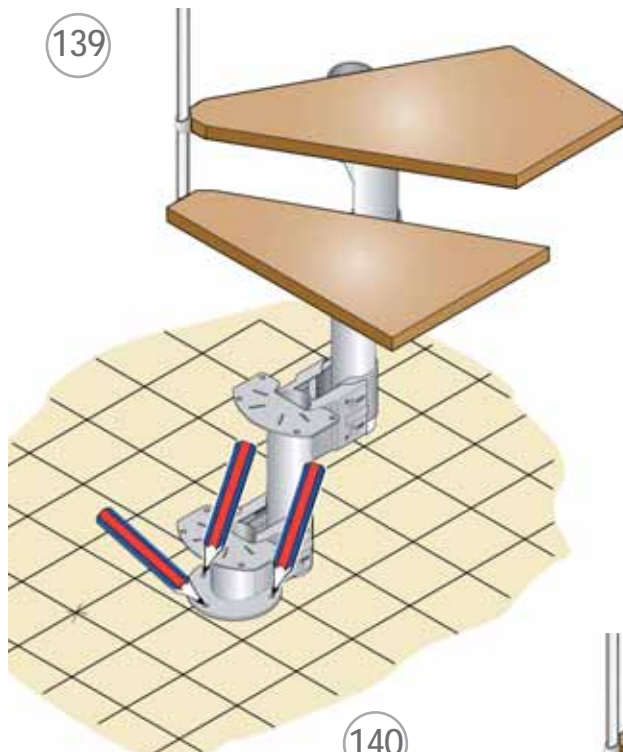

140

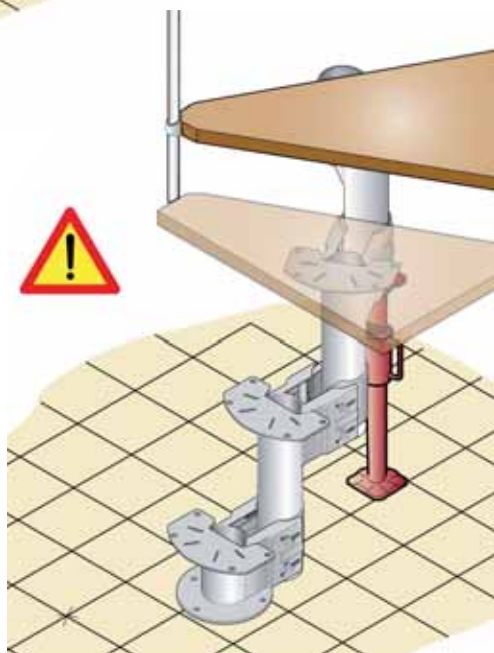



141

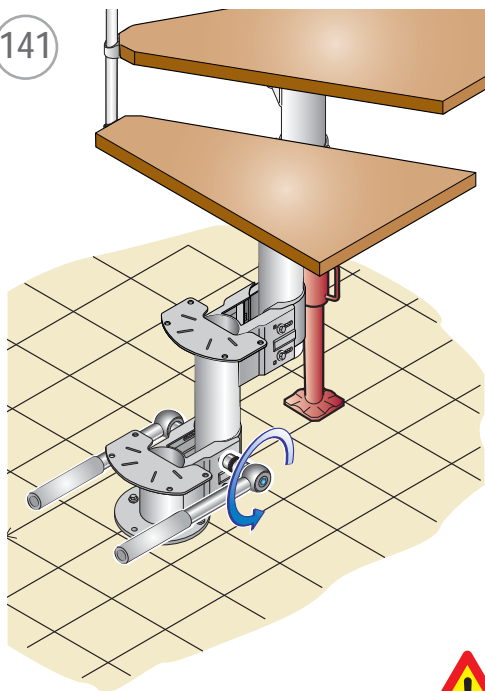

142

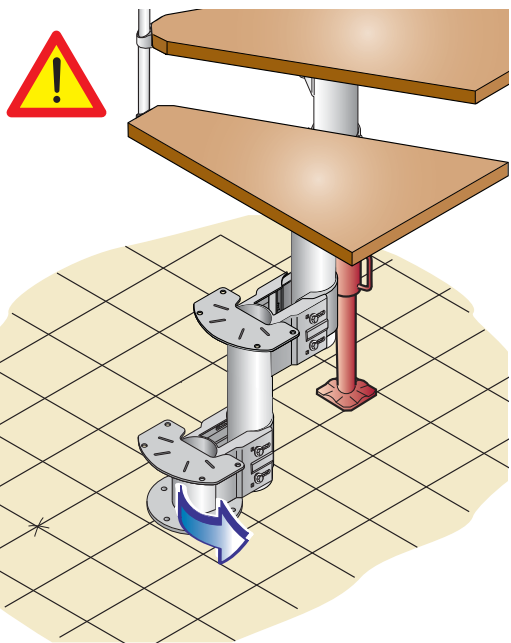



143

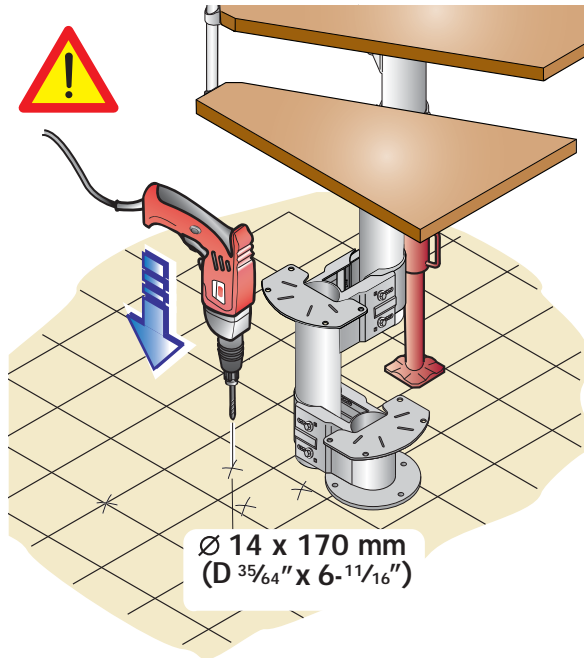

144

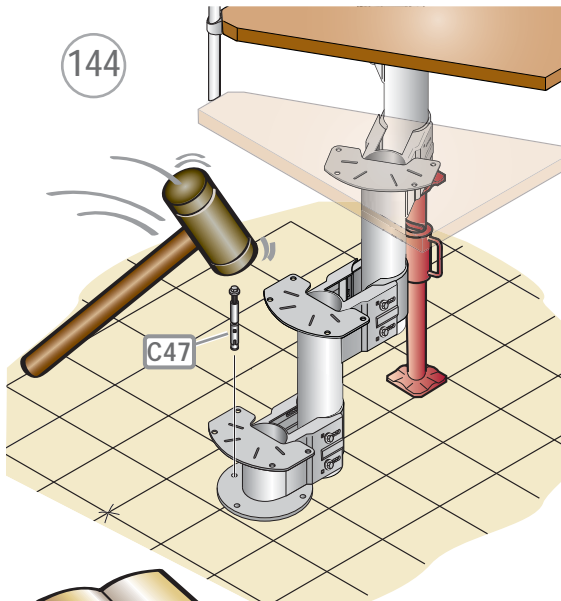

145

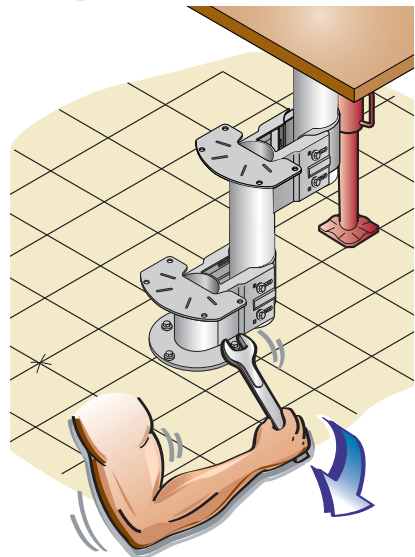

128



146

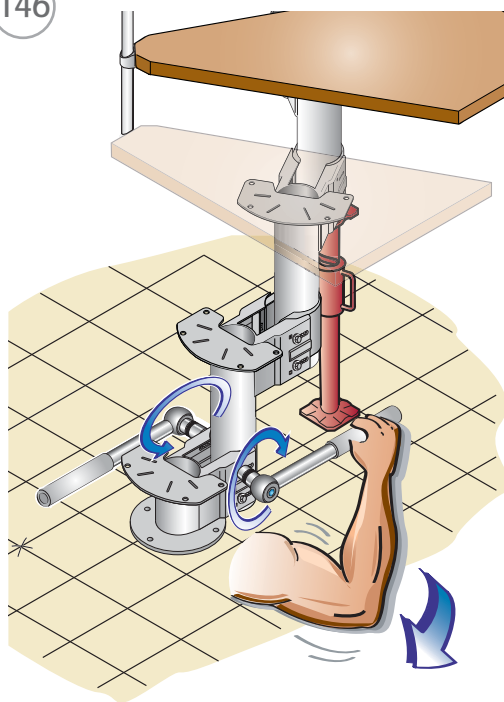

147

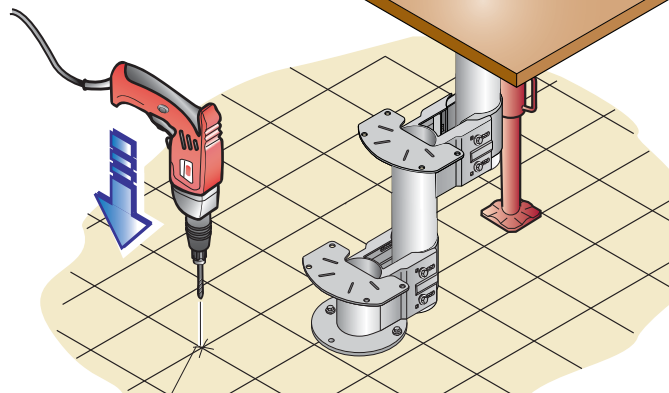

Ø 14 x 170 mm  
(D 35/64" x 6-11/16")

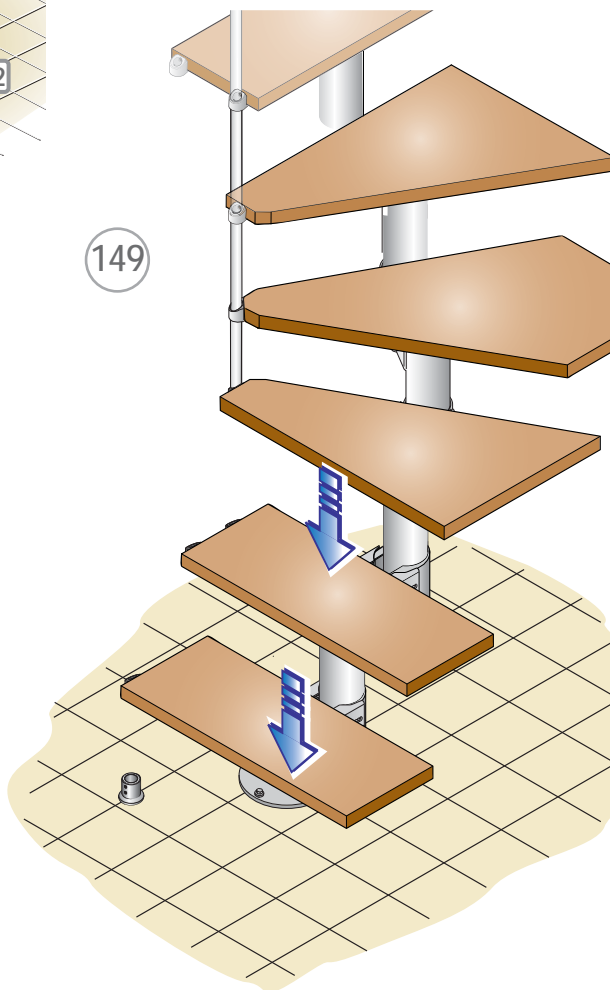
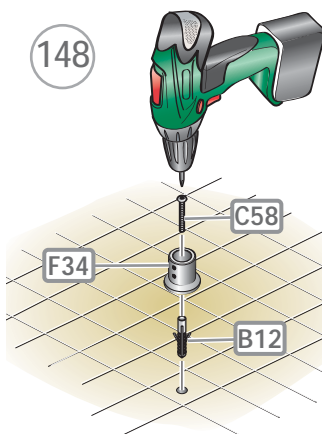

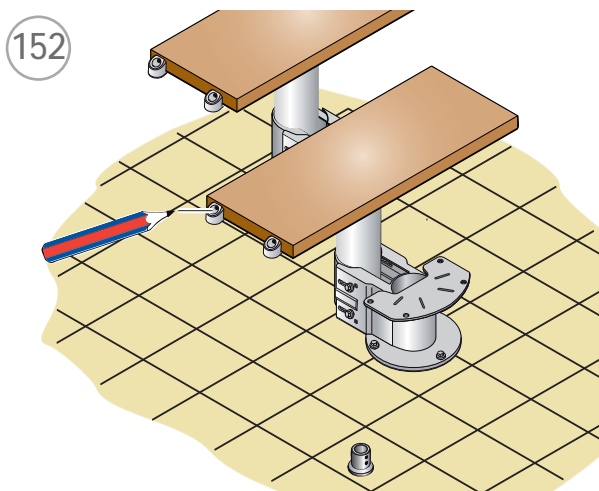
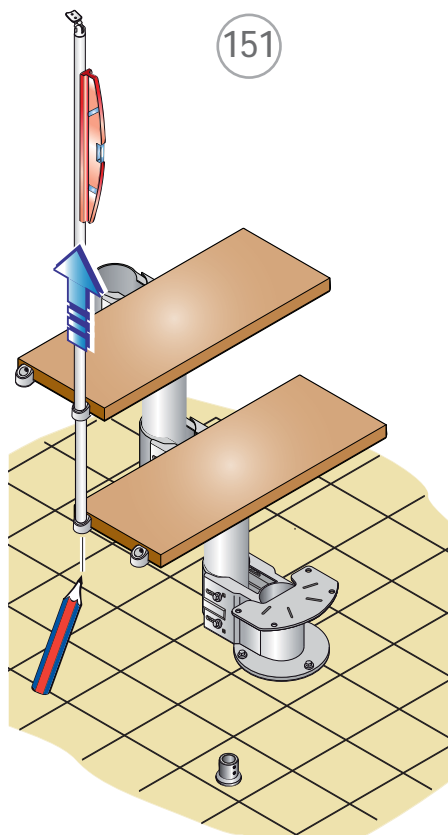
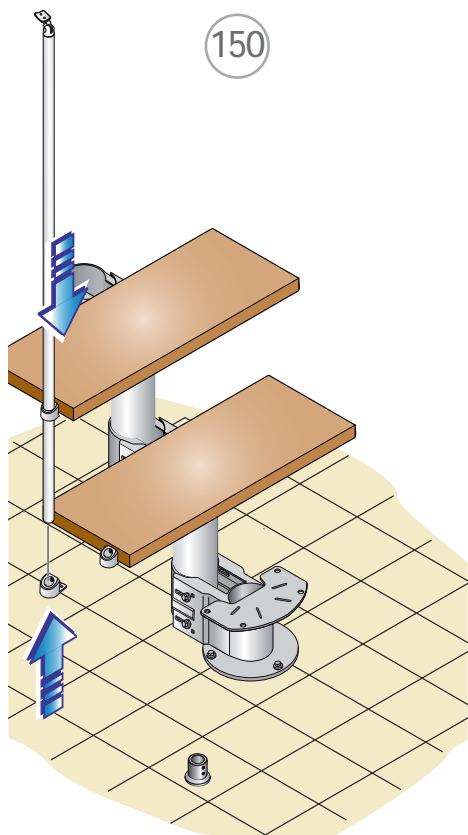

153

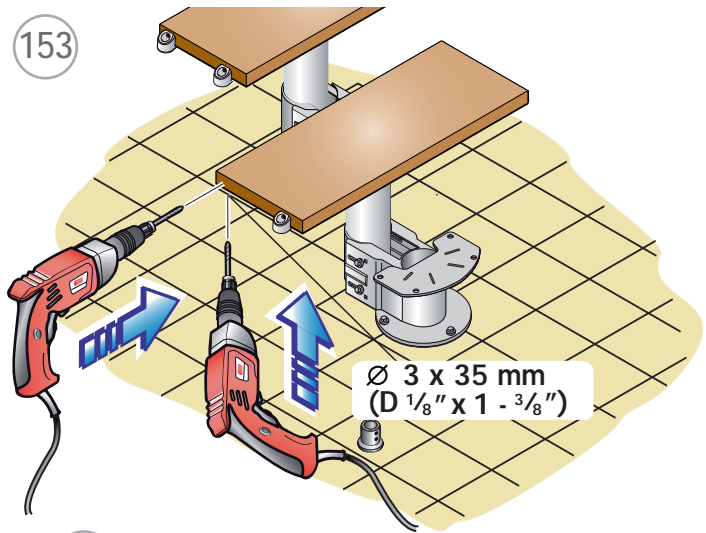

154

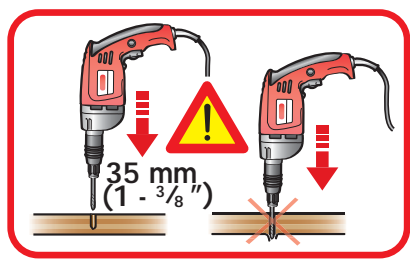
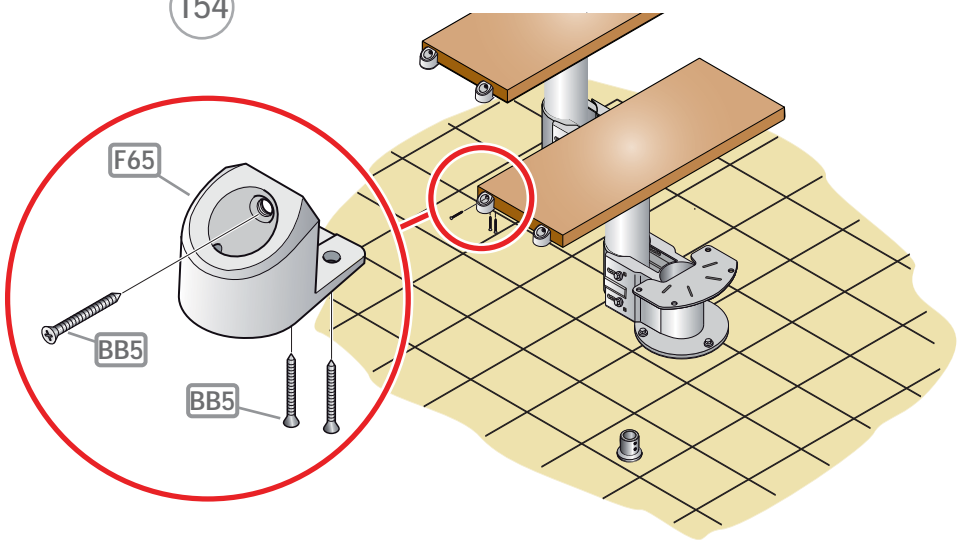

155

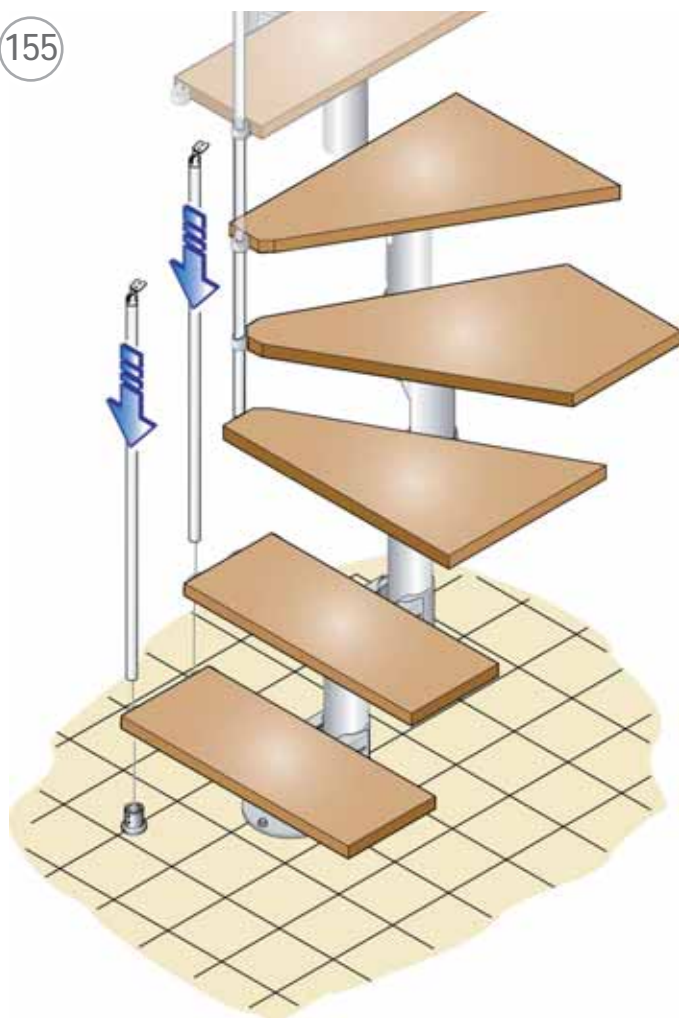

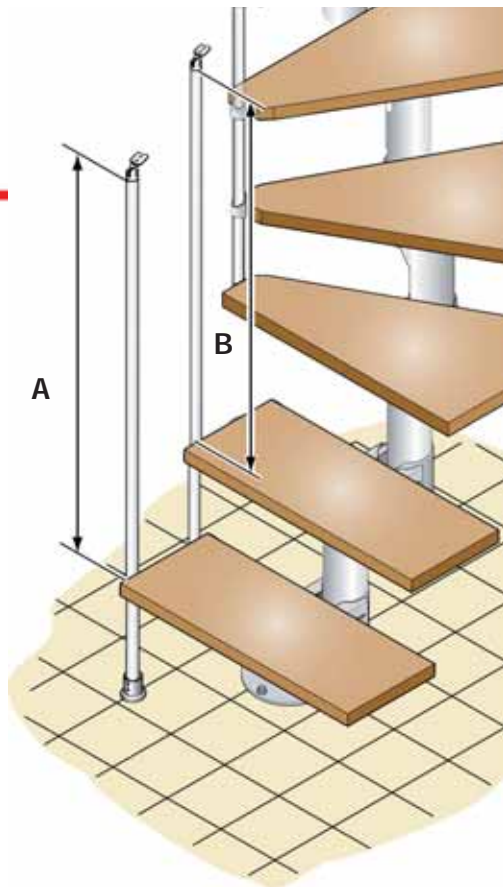
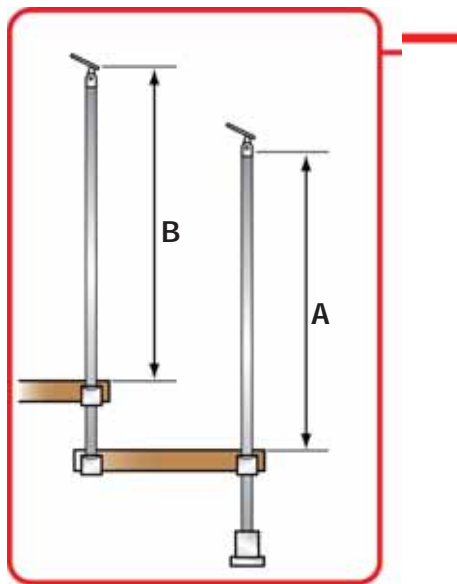

157

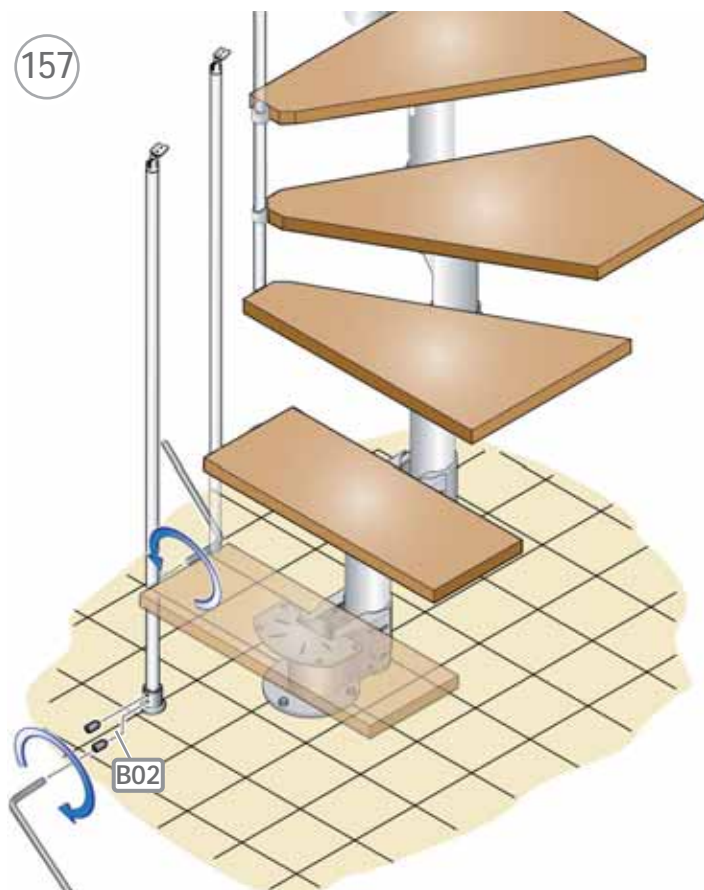

158

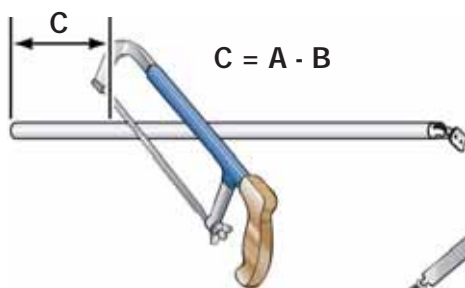

159





160

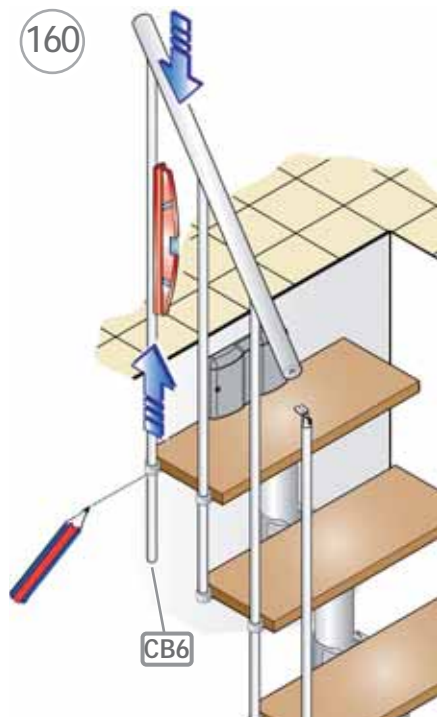

161

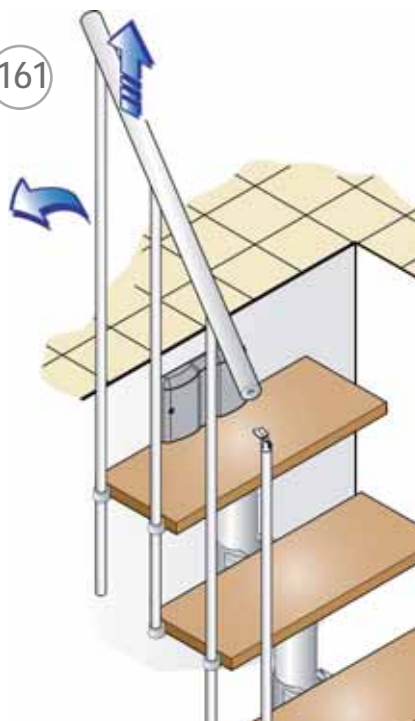

162

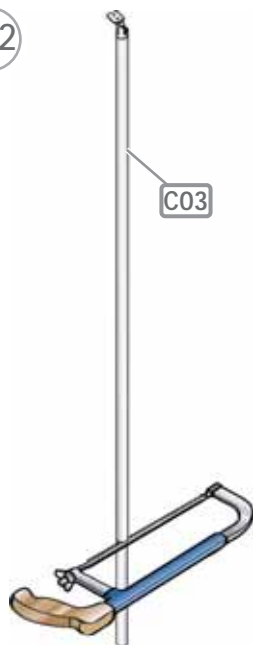

163



164

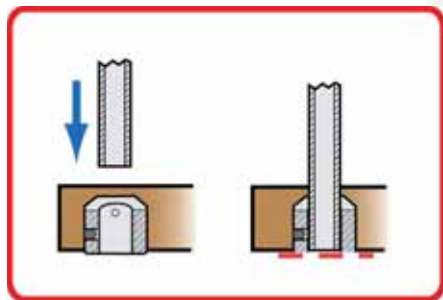
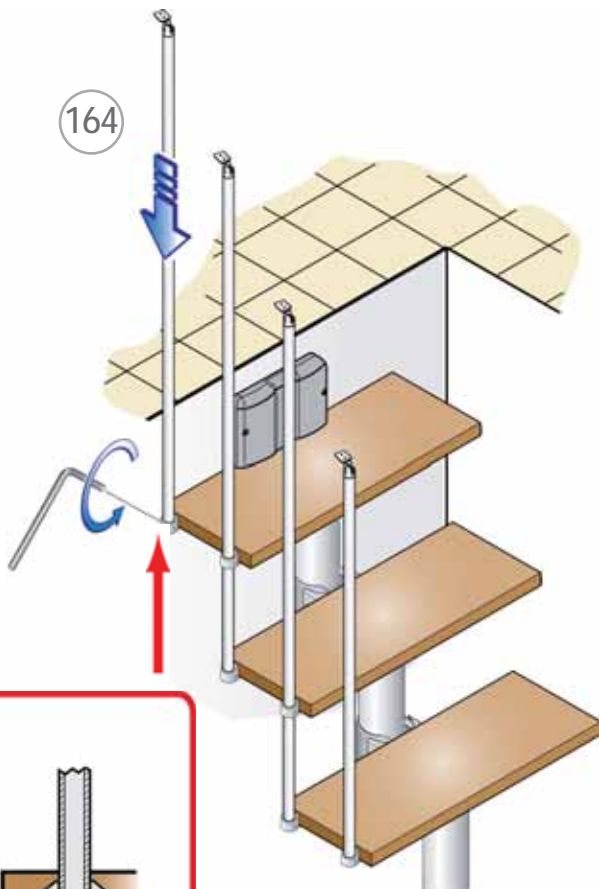

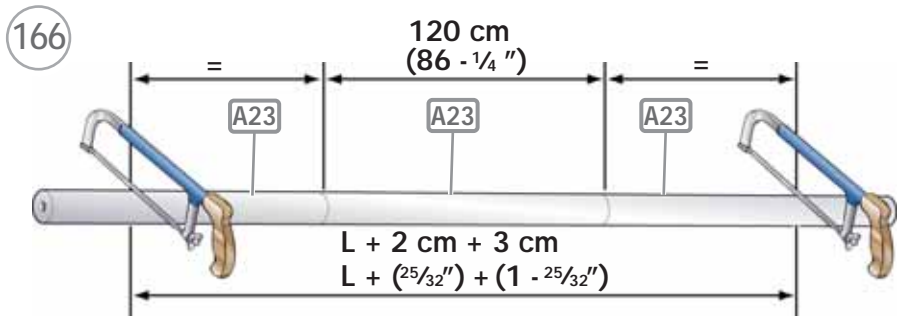
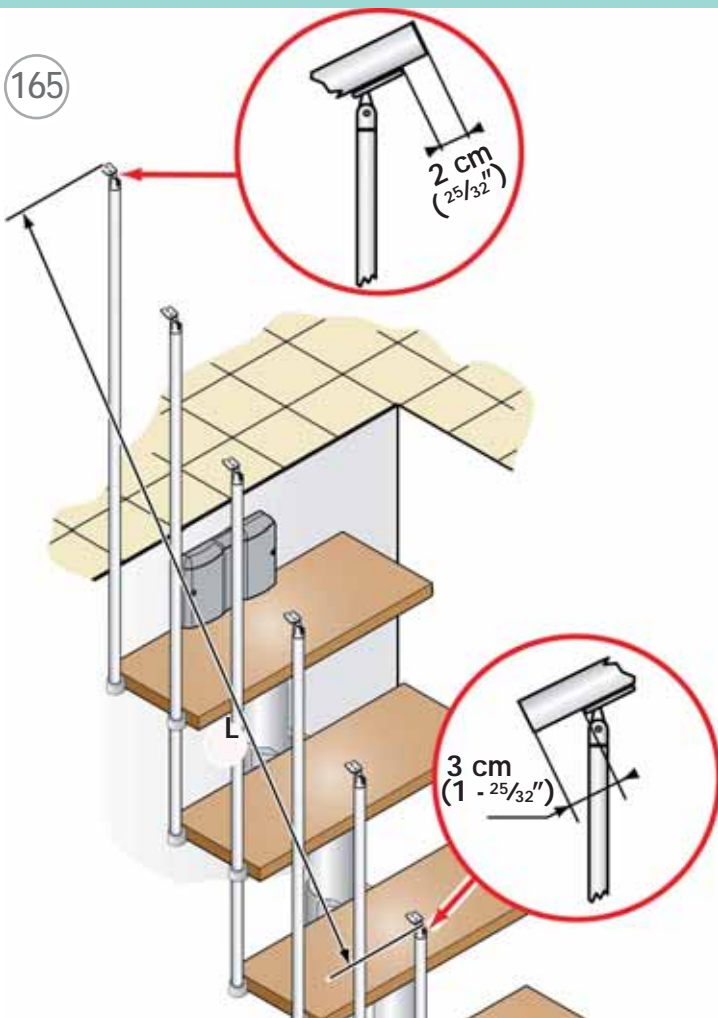

167



168



169

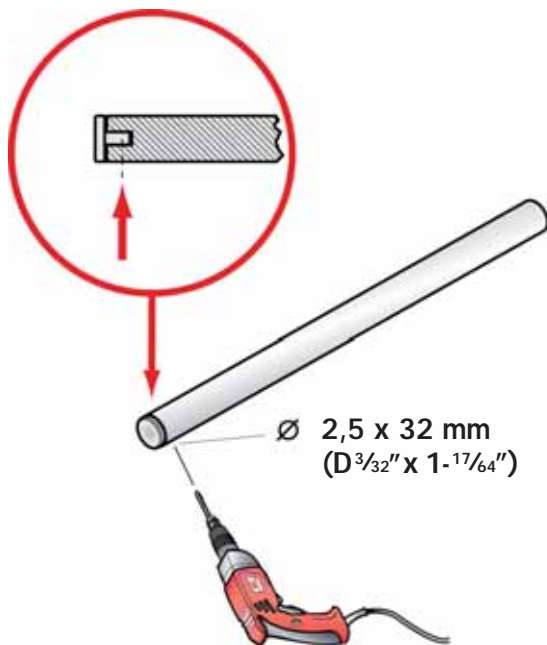

170

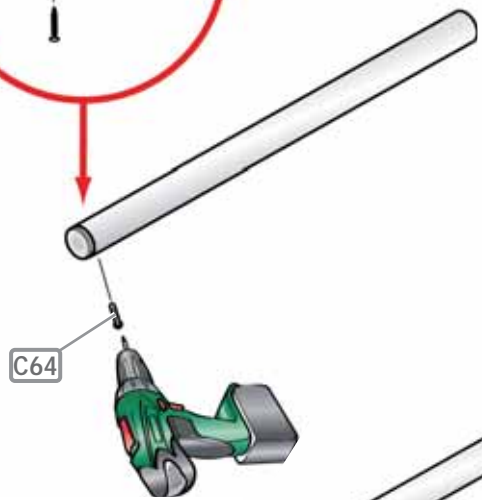
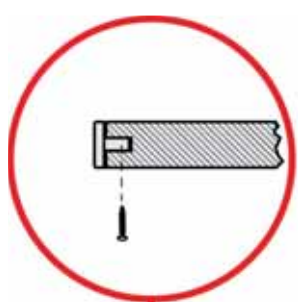

C64

171

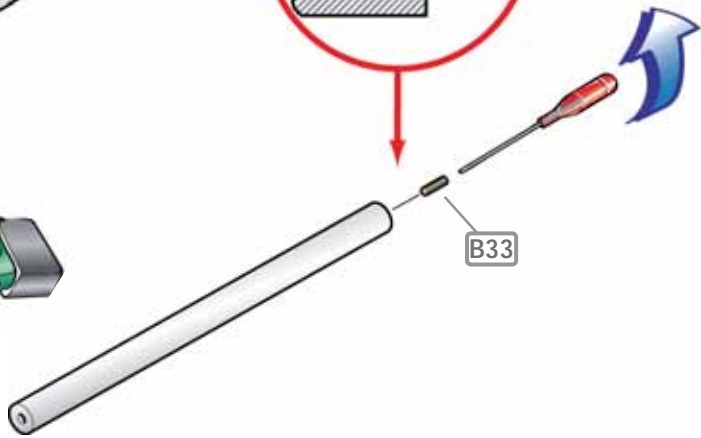
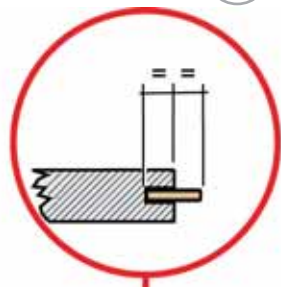

B33

172

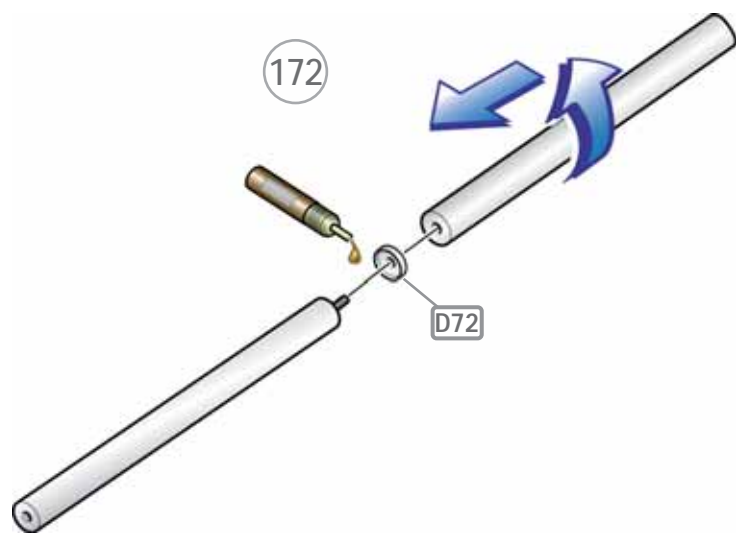

D72

173

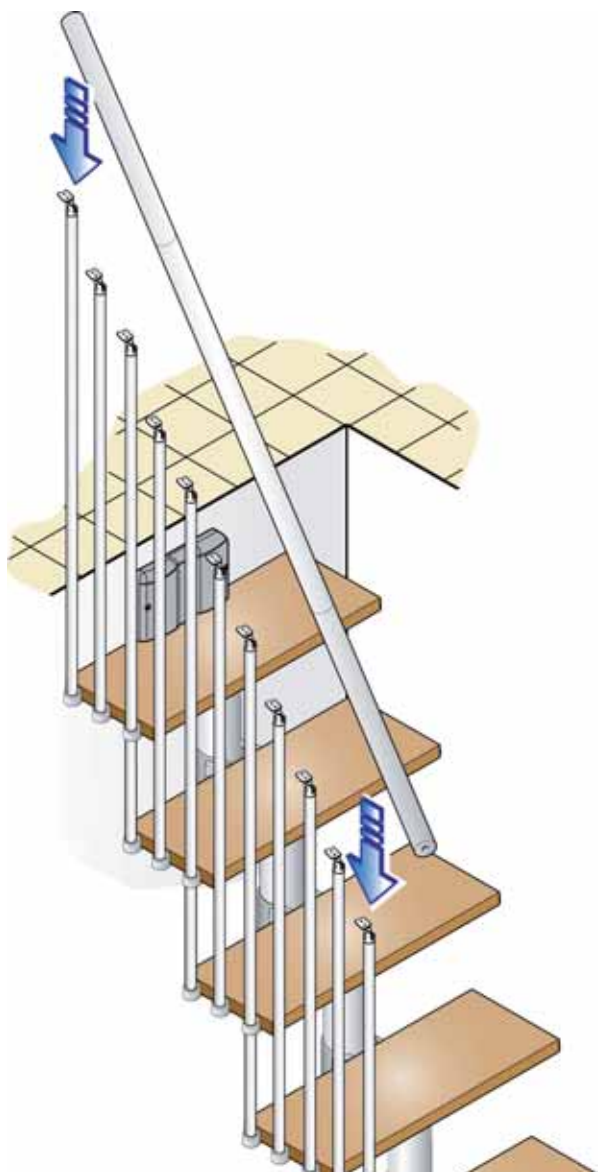

174

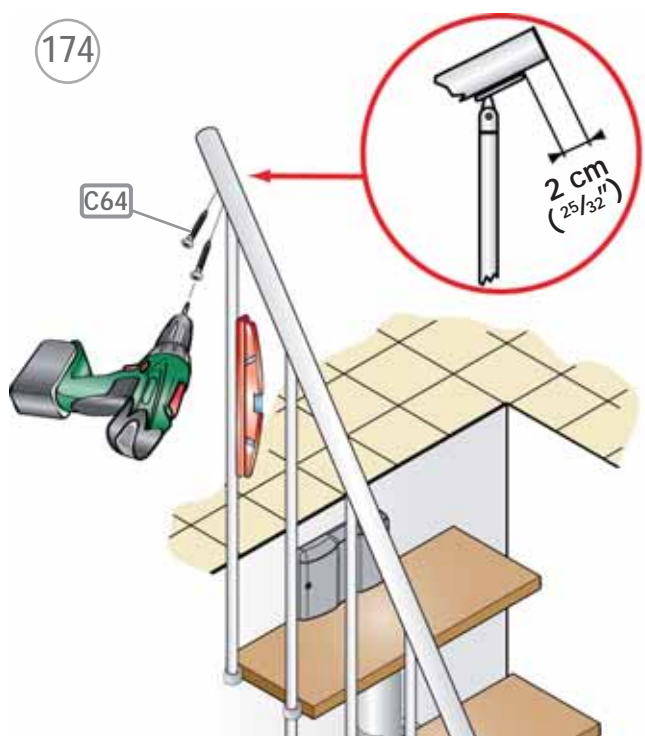

175

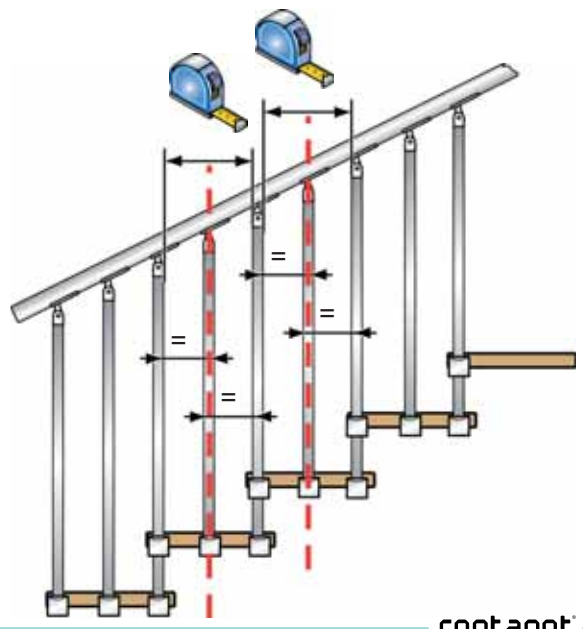

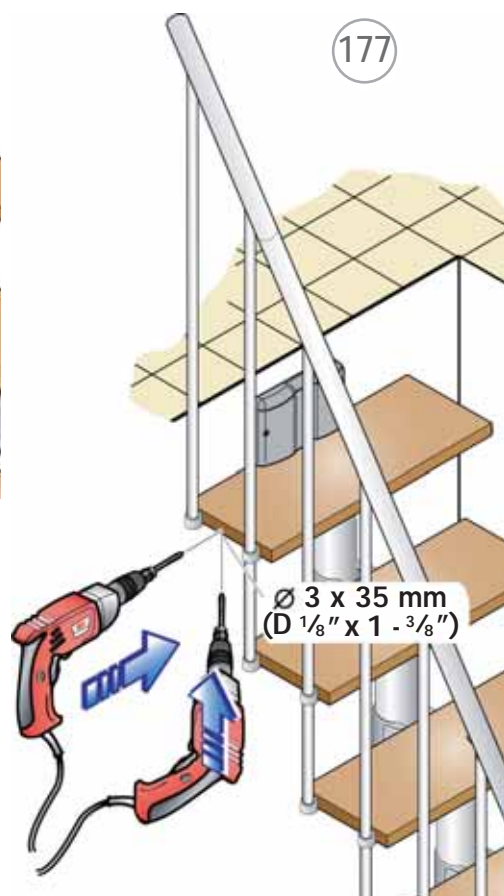
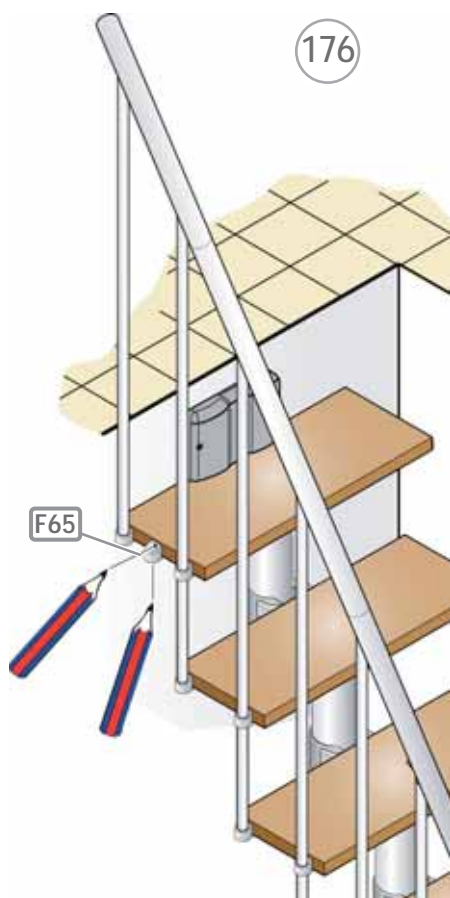



178

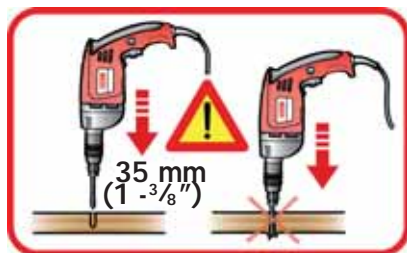
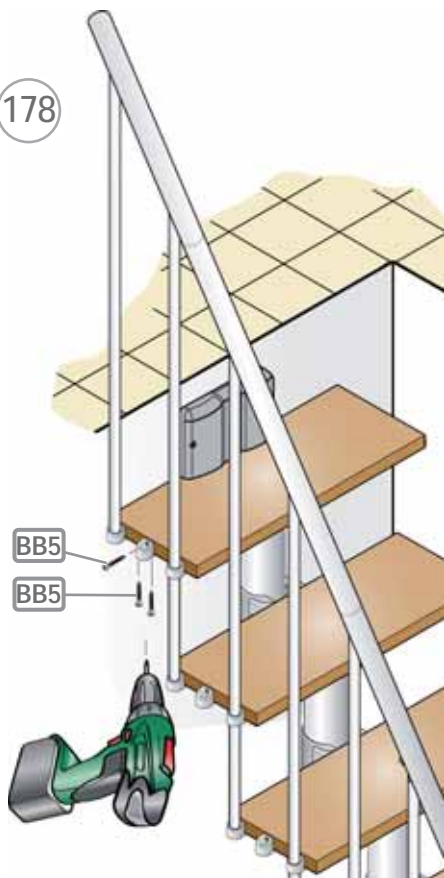

179

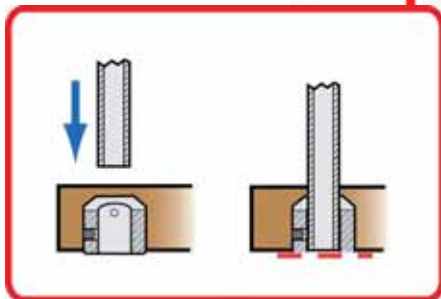
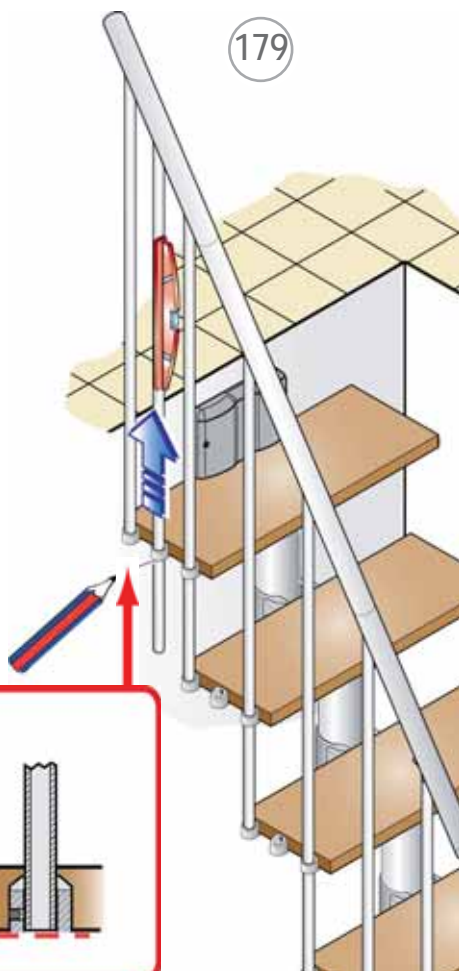

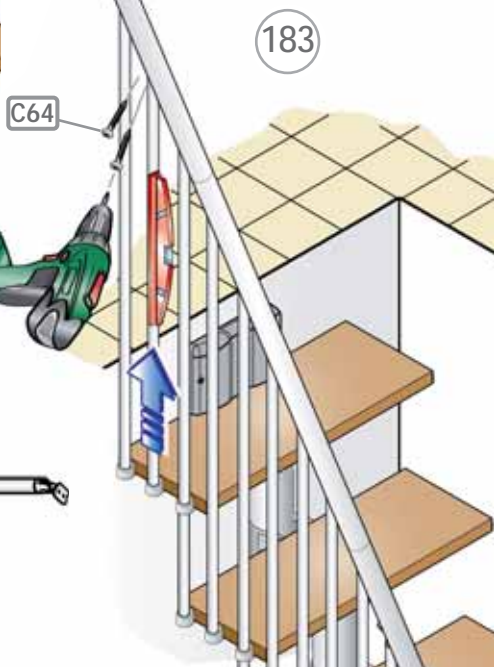
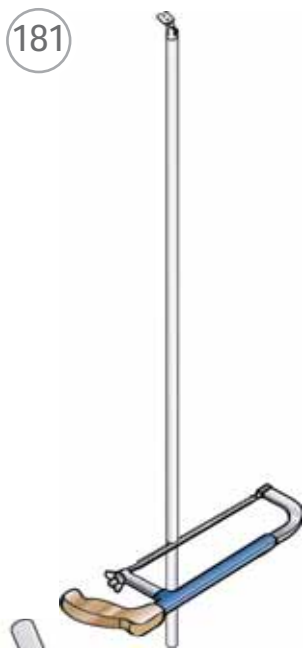

182



184

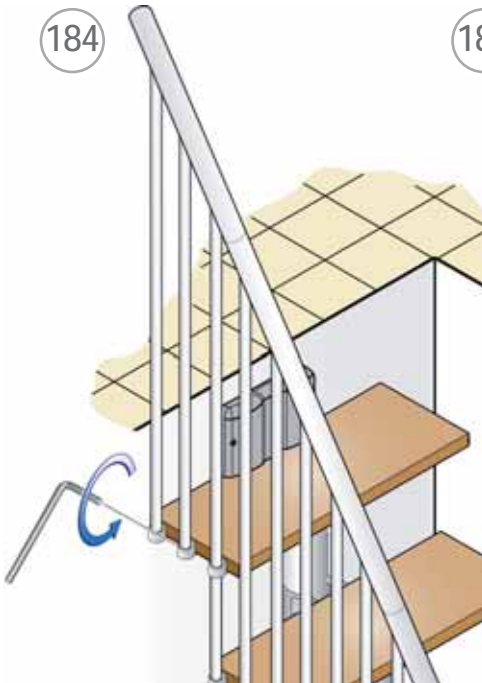

185

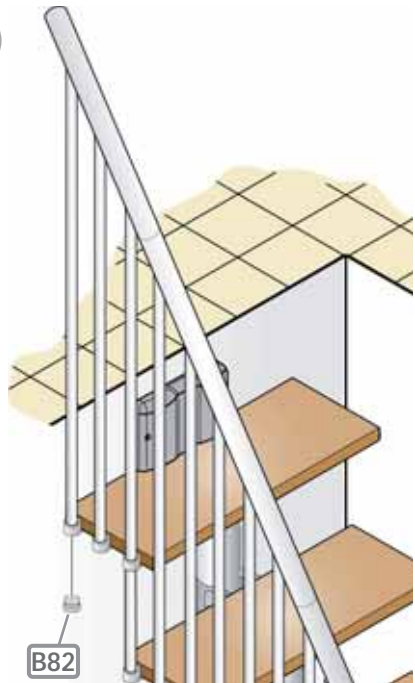

186

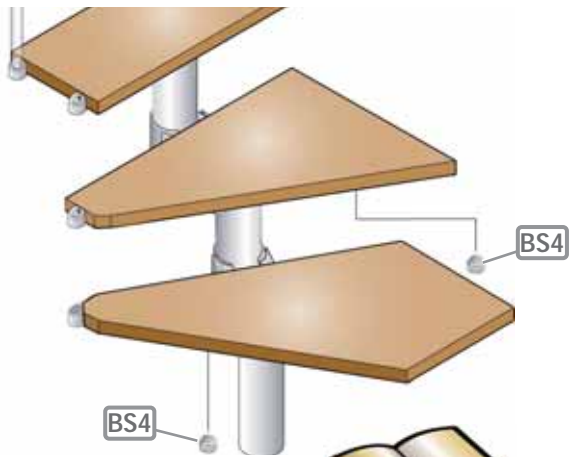

28 - 31 →

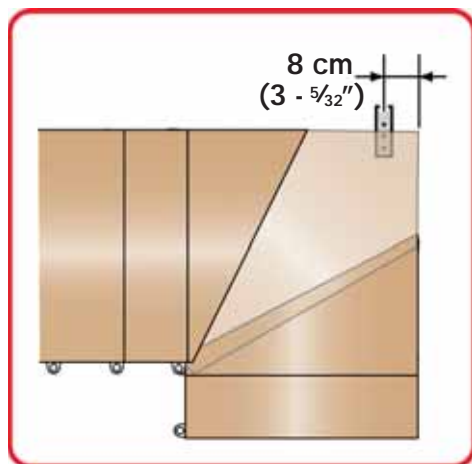
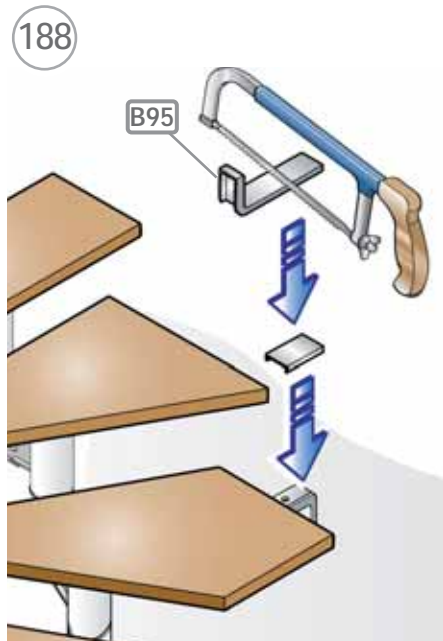
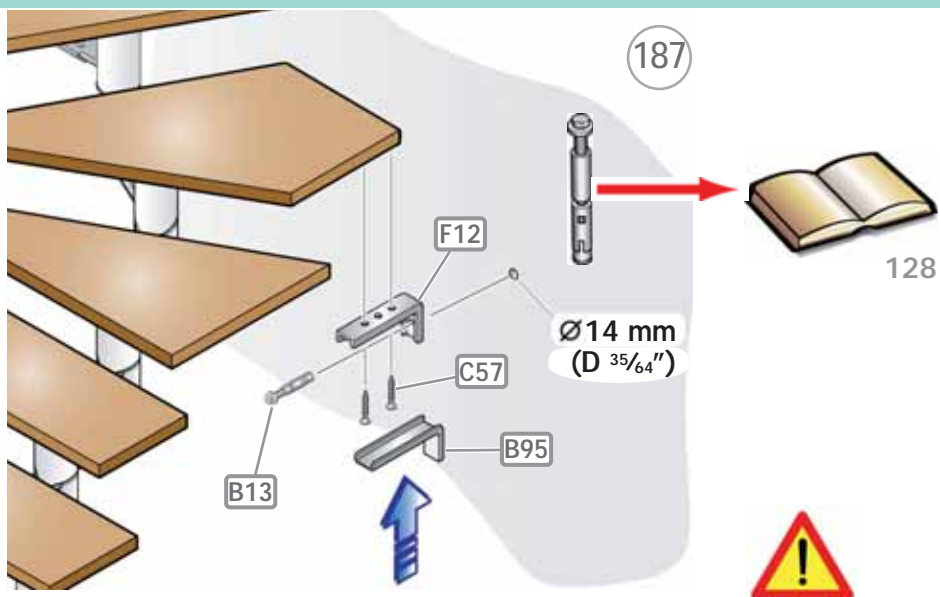

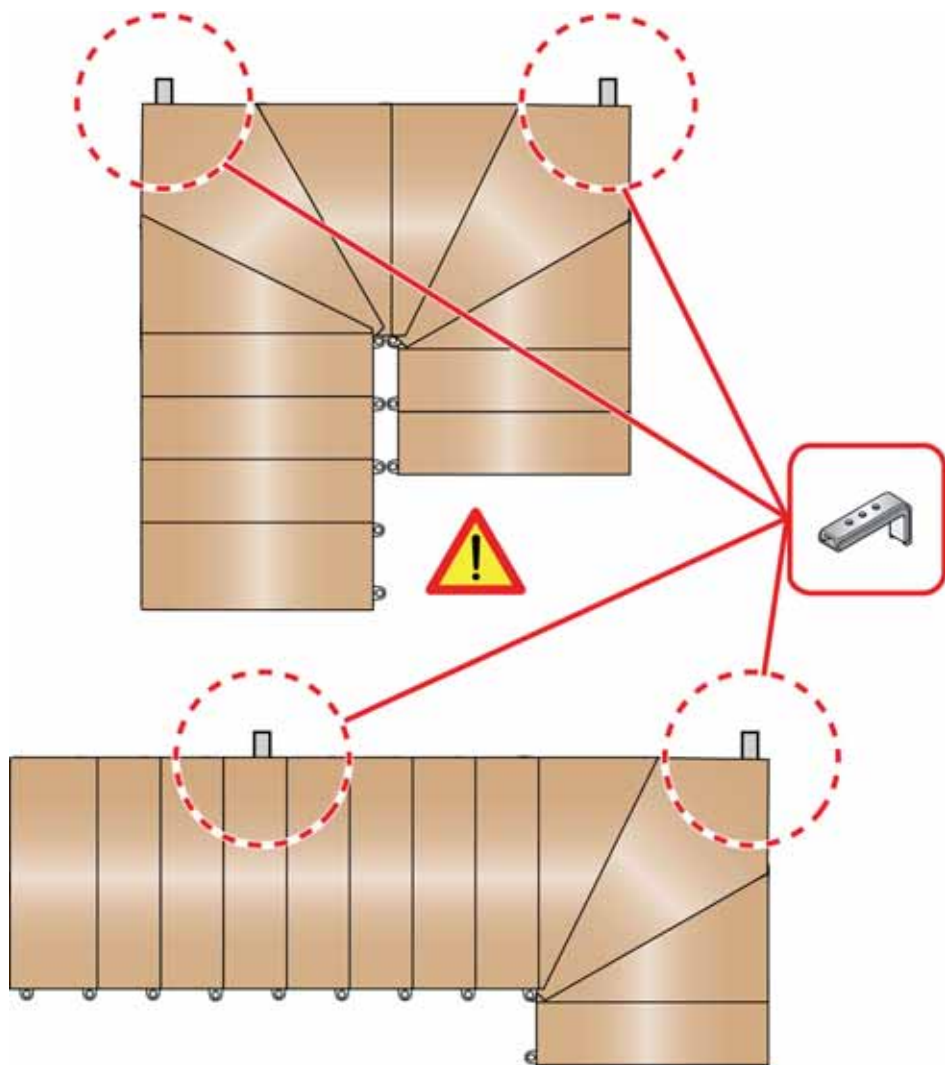

189

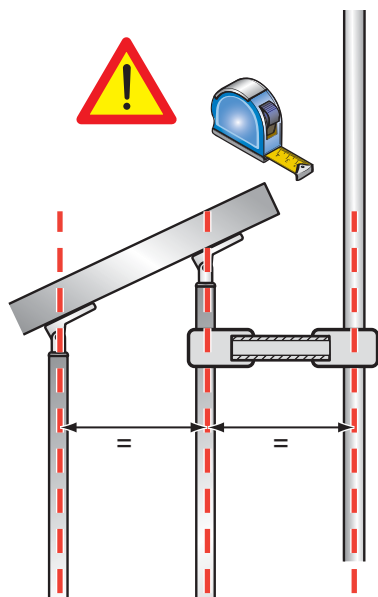

190

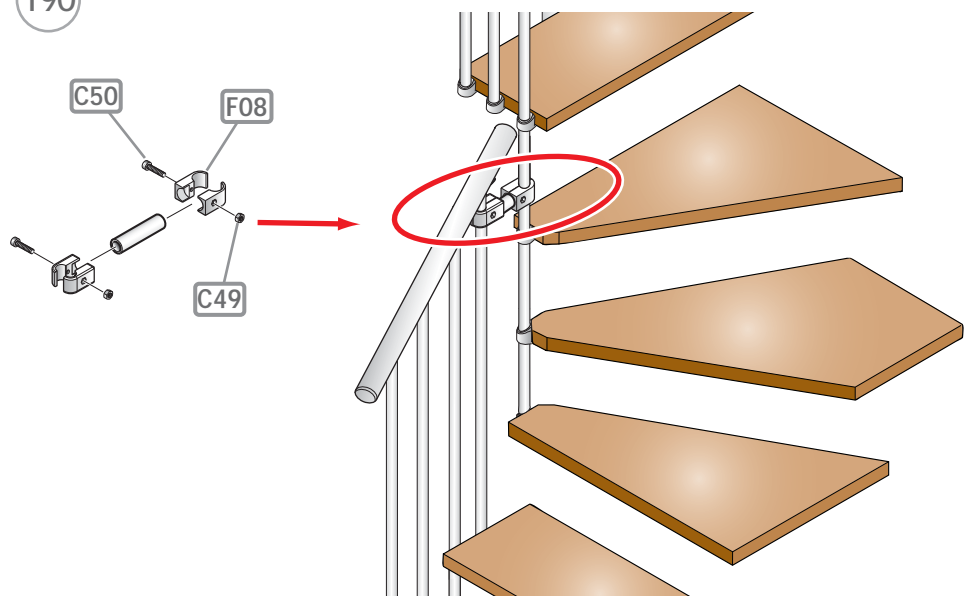

191

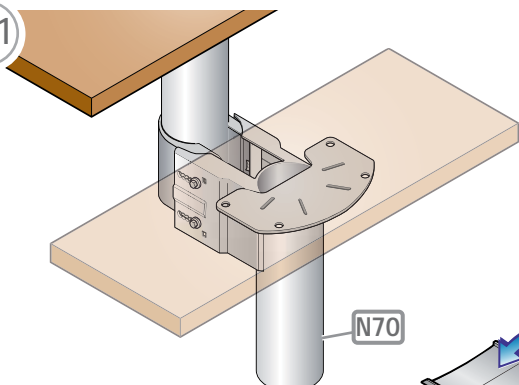

N70

192



D28



19

$L = 65 \div 75 \text{ cm}$   
 $L = (25 - \frac{9}{16}'' ) \div (29 - \frac{1}{2}'' )$   
 $P = 18 \div 22 \text{ cm}$   
 $P = (7 - \frac{3}{32}'' ) \div (8 - \frac{21}{32}'' )$

193

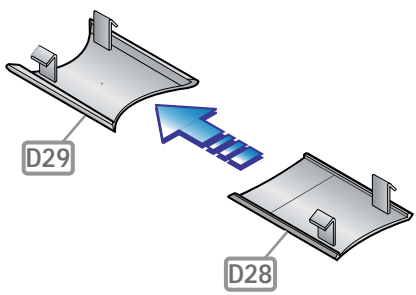

D29

D28

194

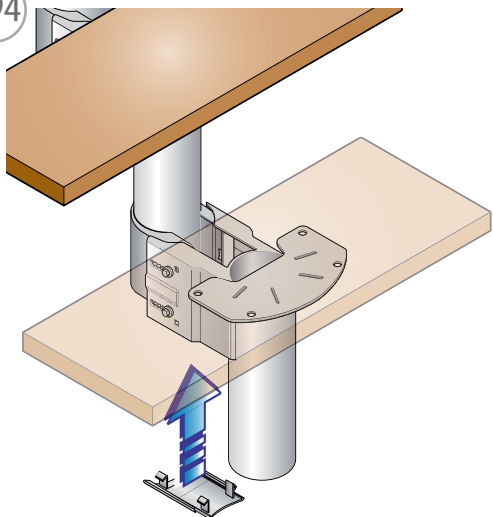

195

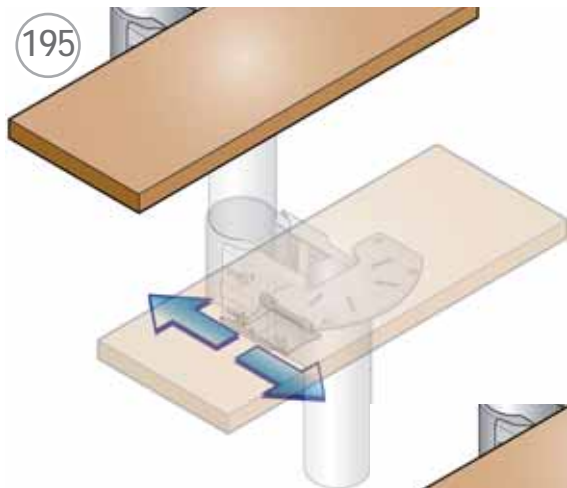

196

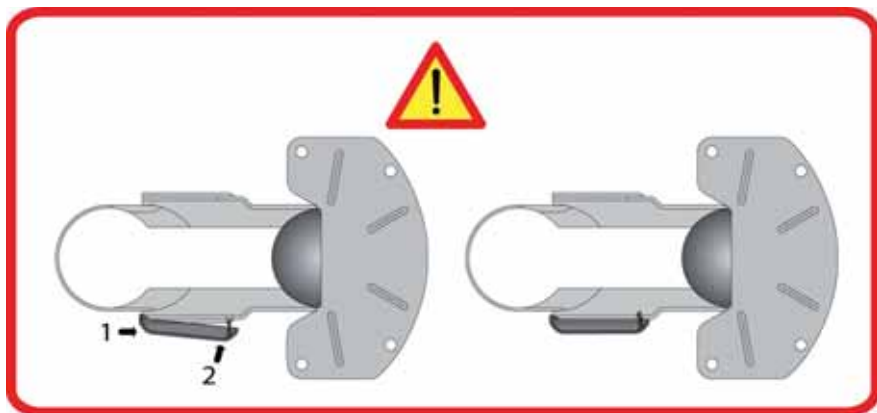
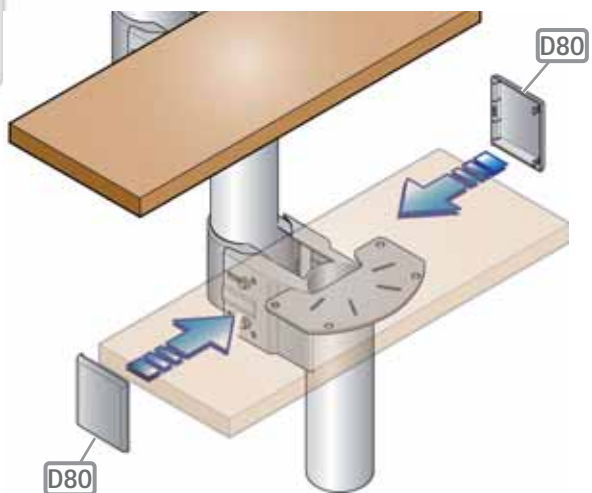



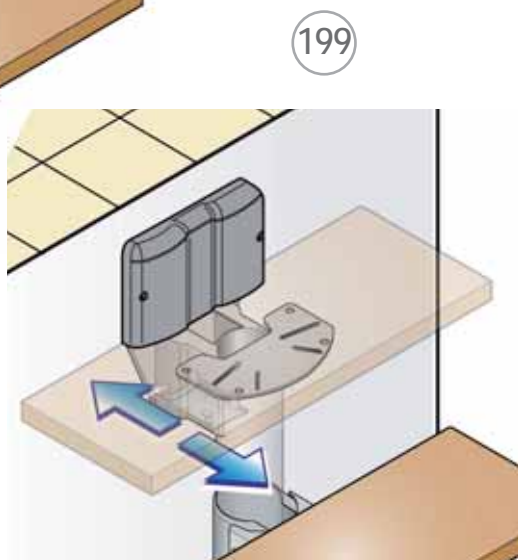
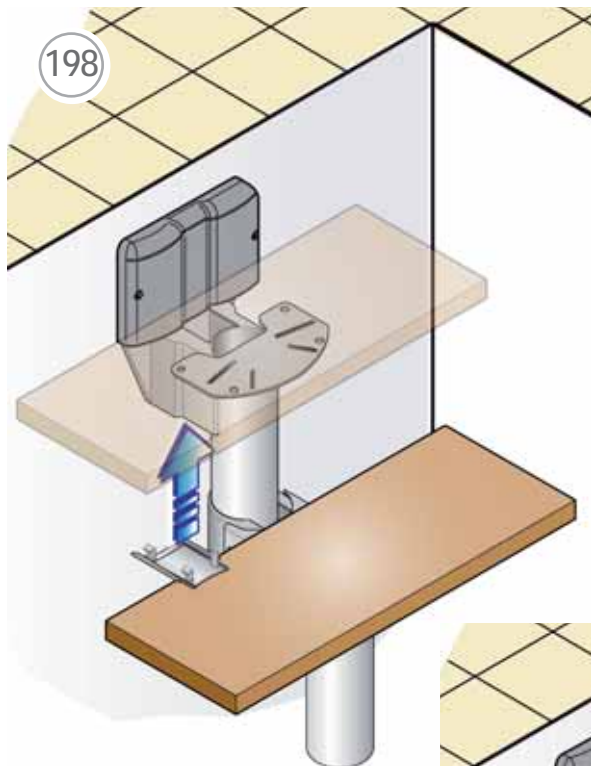
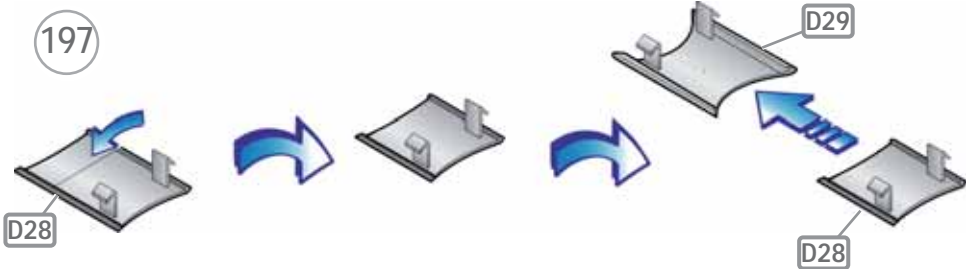

200

Ø 8 X 50 mm  
(D 5/16" X 1-31/32")

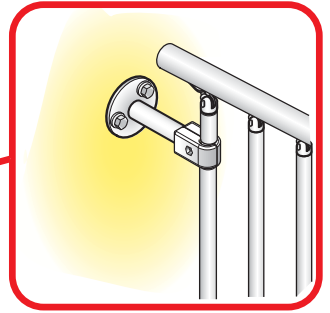
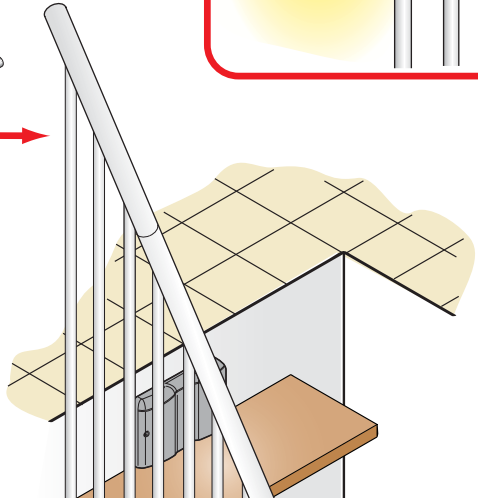
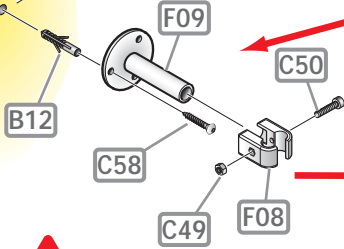

201

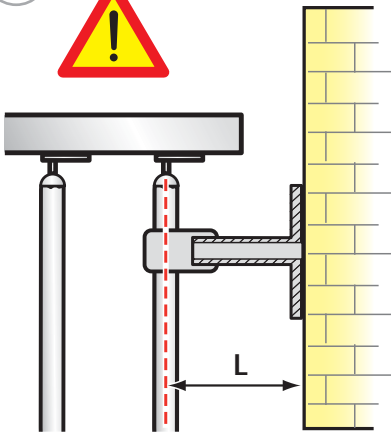

L - 3 cm  
L - (1 - 3/16")

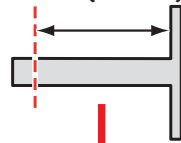

202

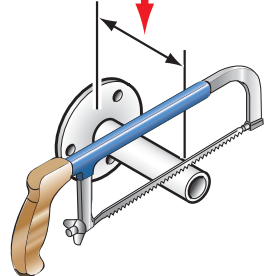

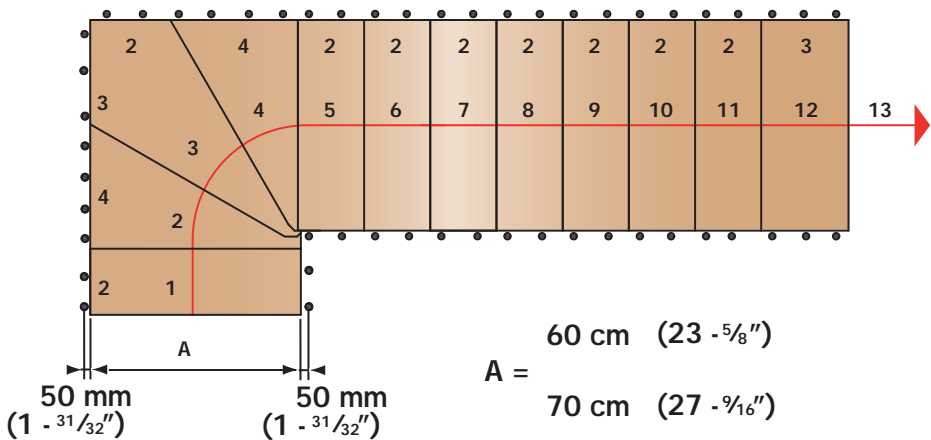
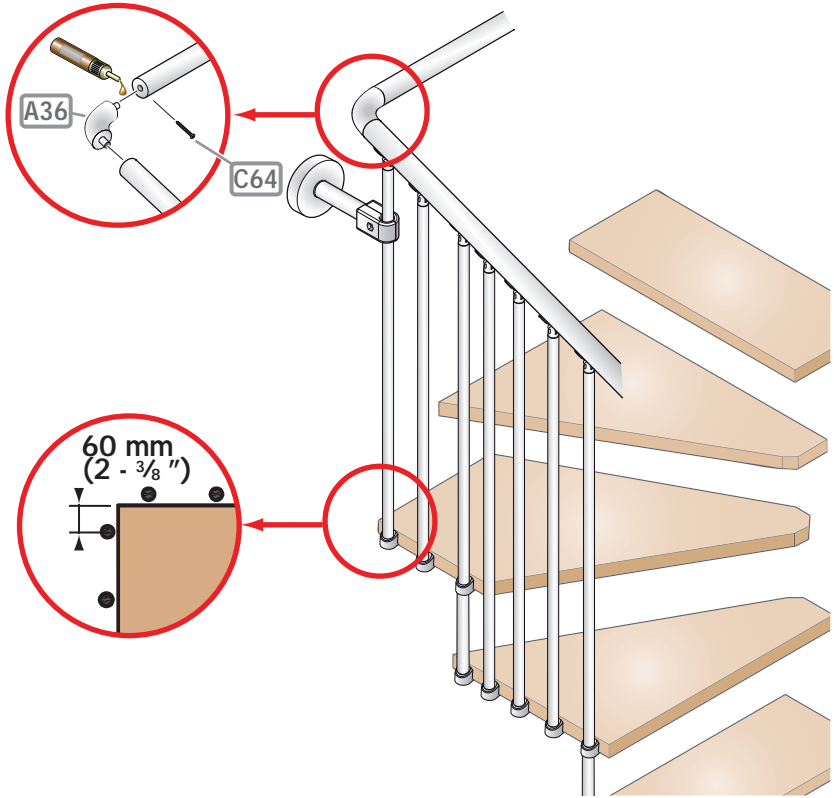

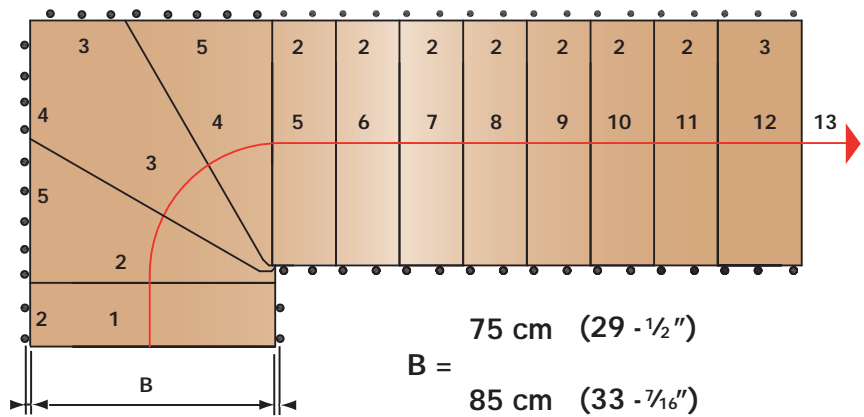
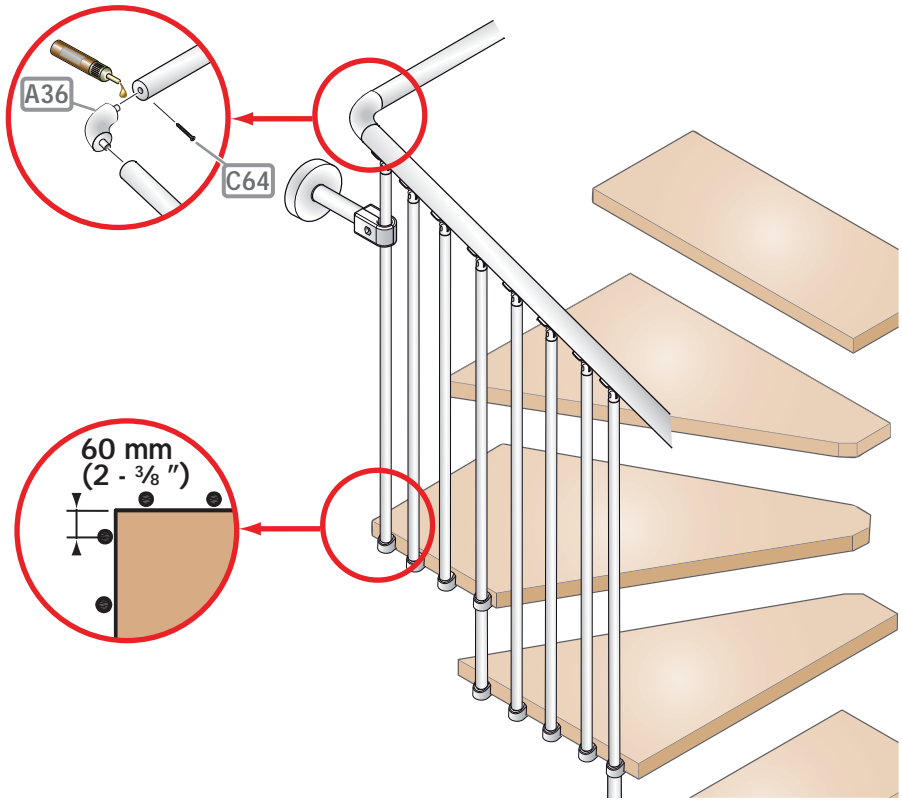



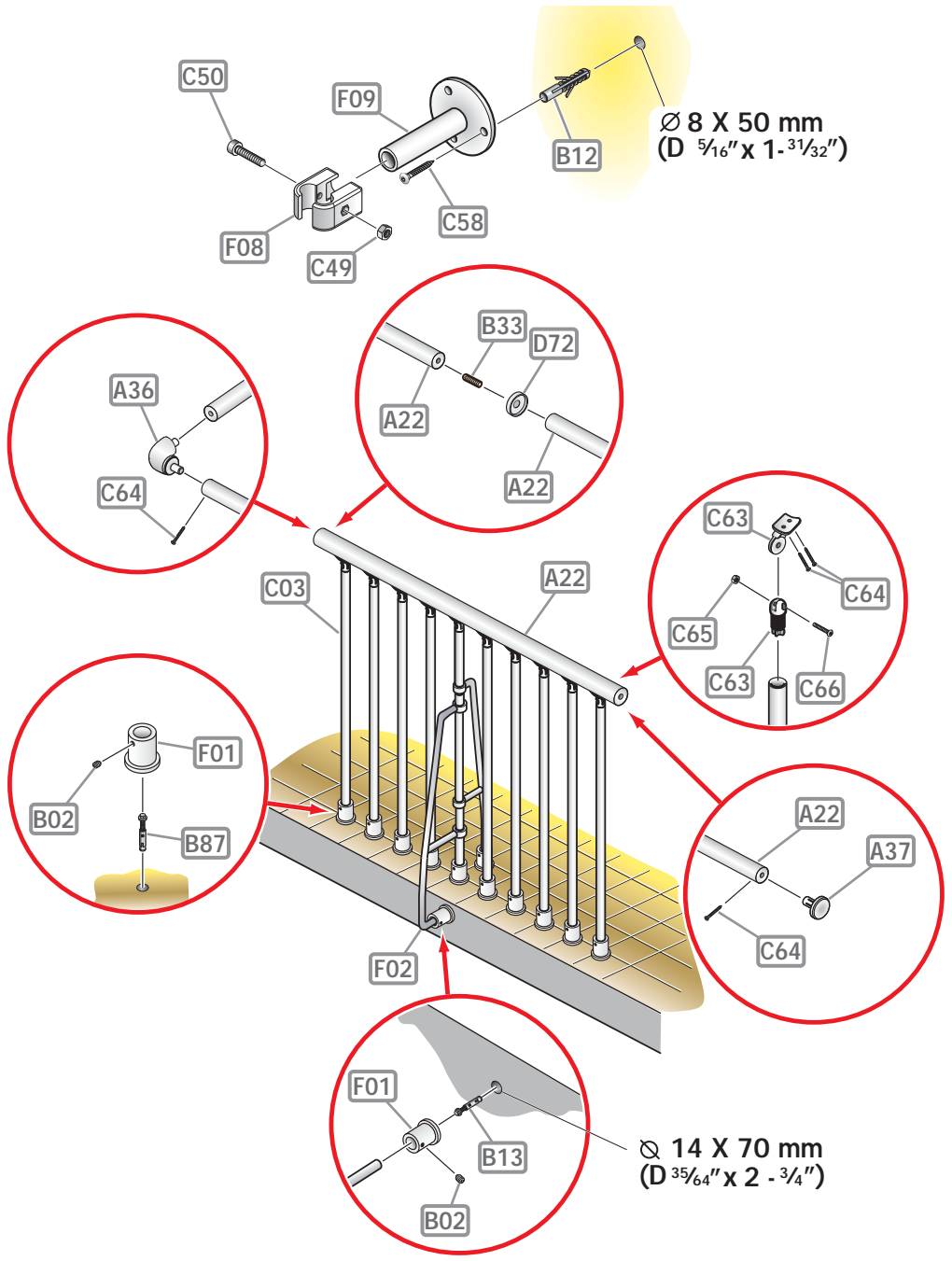

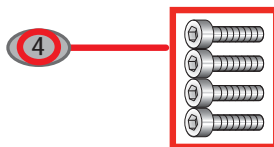

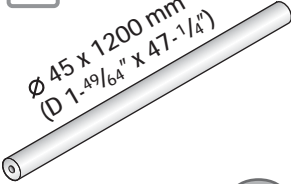







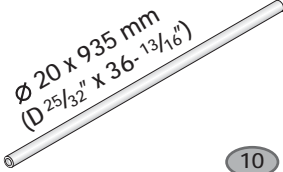



50 mm (1 - 31/32")      50 mm (1 - 31/32")



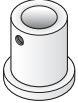
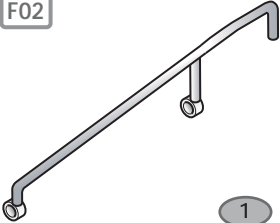

<p>A22</p> <p>Ø 45 x 1200 mm (D 1-<sup>49</sup>/<sub>64</sub>" x 47-<sup>1</sup>/<sub>4</sub>" )</p>  <p>1</p>	<p>A36</p>  <p>1</p>	<p>A37</p>  <p>2</p>
<p>B02</p>  <p>6 x 6 mm (<sup>15</sup>/<sub>64</sub>" x <sup>15</sup>/<sub>64</sub>" )</p> <p>13</p>	<p>B12</p>  <p>Ø 8 mm (D <sup>5</sup>/<sub>16</sub>" )</p> <p>3</p>	<p>B13</p>  <p>M8 mm (M <sup>5</sup>/<sub>16</sub>" )</p> <p>1</p>
<p>B33</p>  <p>M14 x 43 mm (M <sup>35</sup>/<sub>64</sub>" x 1-<sup>11</sup>/<sub>16</sub>" )</p> <p>1</p>	<p>B87</p>  <p>M6 mm (M <sup>15</sup>/<sub>64</sub>" )</p> <p>10</p>	<p>C03</p> <p>Ø 20 x 935 mm (D <sup>25</sup>/<sub>32</sub>" x 36-<sup>13</sup>/<sub>16</sub>" )</p>  <p>10</p>
<p>C49</p>  <p>M6 mm (M <sup>15</sup>/<sub>64</sub>" )</p> <p>1</p>	<p>C50</p>  <p>M6 x 25 mm (M <sup>15</sup>/<sub>64</sub>" x <sup>63</sup>/<sub>64</sub>" )</p> <p>1</p>	<p>C58</p>  <p>M6 x 40 mm (M <sup>15</sup>/<sub>64</sub>" x 1-<sup>37</sup>/<sub>64</sub>" )</p> <p>3</p>

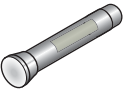
<p>C63</p>  <p>10</p>	<p>C64</p>  <p>M3,5 x 38 mm (M<sup>9</sup>/<sub>64</sub>" x 1-1/2")</p> <p>24</p>	<p>C65</p>  <p>M4 mm (M<sup>5</sup>/<sub>32</sub>" )</p> <p>10</p>
<p>C66</p>  <p>M4 x 14 mm (M<sup>5</sup>/<sub>32</sub>" x 35/64")</p> <p>10</p>	<p>D72</p>  <p>1</p>	<p>F01</p>  <p>11</p>
<p>F02</p>  <p>1</p>	<p>F08</p>  <p>2</p>	<p>F09</p>  <p>1</p>
<p>X01</p>  <p>1</p>		

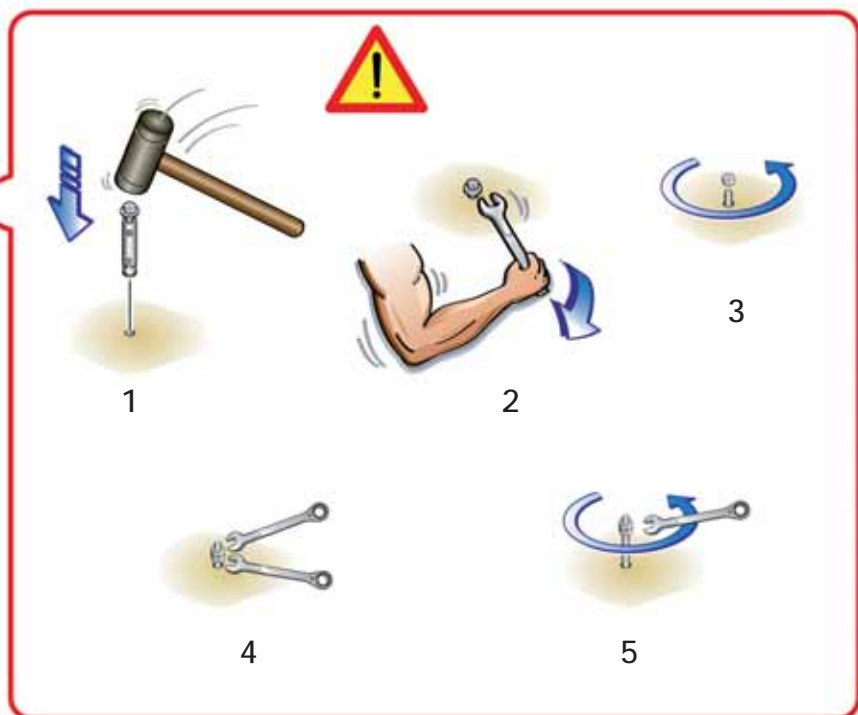





<b>Italiano</b>	DATI IDENTIFICATIVI DEL PRODOTTO
<b>Français</b>	DONNÉES D'IDENTIFICATION DU PRODUIT
<b>English</b>	PRODUCT DETAILS
<b>Deutsch</b>	PRODUKTEIGENSCHAFTEN
<b>Español</b>	DATOS DE IDENTIFICACIÓN DEL PRODUCTO
<b>Nederlands</b>	IDENTIFICATIE VAN HET PRODUCT
<b>Svenska</b>	PRODUKTDETALJER
<b>Dansk</b>	PRODUKTETS IDENTIFIKATIONSDATA
<b>Norsk</b>	PRODUKTINFORMASJON
<b>Suomi</b>	TUOTTEEN TUNNISTETIEDOT



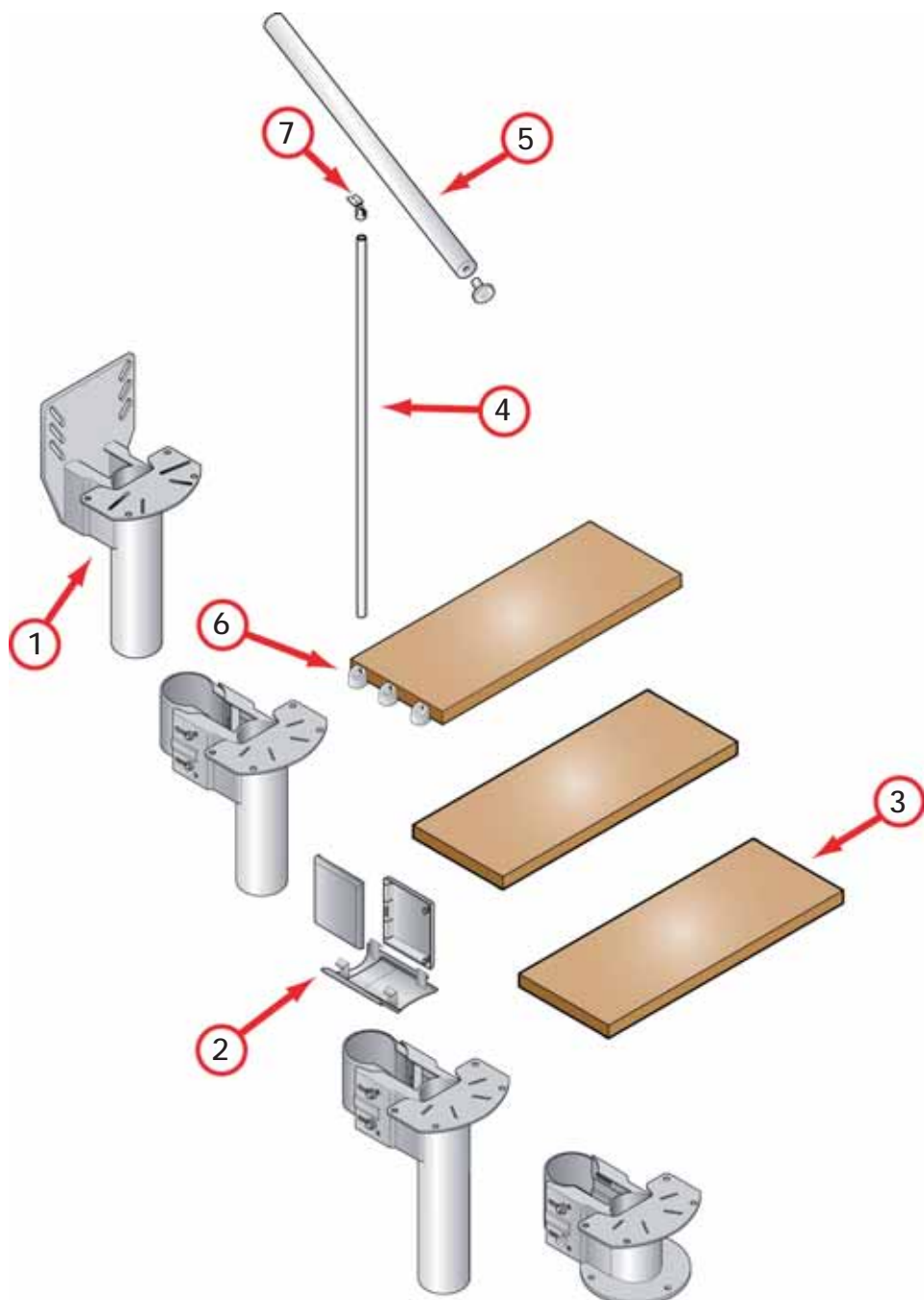

IT)

## **dati identificativi del prodotto**

denominazione commerciale: **L**

tipologia: scala a giorno con gradini rettilinei, a ventaglio e rotazione delle rampe

### **materiali impiegati**

#### **STRUTTURA**

##### **descrizione**

composta da supporti (1) metallici assemblati fra di loro con bulloni

##### **materiali**

supporti metallici: Fe 370

coperchi di chiusura (2): polipropilene e ABS

##### **finitura**

supporti: verniciatura a forno con polveri epossidiche

#### **GRADINI**

##### **descrizione**

gradini (3) a ventaglio assemblati alla struttura con bulloni

##### **materiali**

multistrato di betulla, HPL

#### **RINGHIERA**

##### **descrizione**

composta da colonnine (4) verticali in metallo fissate ai gradini (3) e da un corrimano (5) di PVC

##### **materiali**

colonnine: Fe 370

corrimano: PVC con anima in alluminio

fissaggi (6) (7): nylon

##### **finitura**

colonnine: verniciatura a forno con polveri epossidiche

#### **PULIZIA E MANUTENZIONE OBBLIGATORIA**

Eseguire la pulizia della scala alla prima comparsa di macchie di sporco e depositi di polvere e periodicamente almeno ogni 6 mesi con panno morbido inumidito in acqua e detergenti specifici non abrasivi ed aggressivi. NON usare mai pagliette abrasive o in ferro. Pulire ed asciugare accuratamente dopo il lavaggio con un panno in microfibra al fine di eliminare gli aloni del calcare presente nell'acqua. Dopo circa 12 mesi dalla data di installazione, controllare il serraggio della viteria dei vari componenti. Al verificarsi di qualsiasi minimo malfunzionamento è obbligatorio effettuare una manutenzione straordinaria, da eseguire subito e a regola d'arte.

#### **PRECAUZIONI D'USO**

Evitare usi impropri e non consoni al prodotto. Eventuali manomissioni o installazioni non rispondenti alle istruzioni del produttore possono inficiare le conformità prestabilite del prodotto.

FR)

## **données d'identification du produit**

denomination commerciale : **L**

typologie: escalier à volée avec marches rectilignes, en éventail et rotation des volées

### **matériaux utilisés**

#### **STRUCTURE**

##### **description**

composée de supports (1) métalliques assemblés entre eux par boulonnage

##### **matériaux**

supports métalliques : Fe 370

caches de fermeture (2) : polypropylène et ABS

##### **finition**

supports : vernissage à chaud avec poudres époxy

#### **MARCHES**

##### **description**

marches (3) rectilignes, en éventail assemblées à la structure par boulonnage

##### **matériaux**

contreplaqué bouleau, HPL

#### **GARDE-CORPS**

##### **description**

composé de colonnettes (4) verticales en metal fixées aux marches (3) d'une main courante en PVC (5)

##### **matériaux**

colonnettes : Fe 370

main courante : PVC avec noyau en aluminium

fixations (6) (7) : nylon

##### **finition**

colonnettes : vernissage à chaud avec poudres époxy

#### **NETTOYAGE ET MAINTENANCE OBLIGATOIRE**

Nettoyer les marches dès que des taches de saleté ou des dépôts de poussière apparaissent ; effectuer également un nettoyage périodique, tous les 6 mois, à l'aide d'un chiffon doux, humecté d'eau et de détergents spécifiques non abrasifs et non agressifs. NE JAMAIS utiliser de la paille de fer abrasive. Après lavage, nettoyer et essuyer soigneusement avec un chiffon en microfibra, afin d'éliminer les auréoles provoquées par le calcaire contenu dans l'eau. Environ 12 mois après la date d'installation, contrôler le serrage des vis des différents composants. À la moindre défaillance, il est obligatoire d'effectuer immédiatement une maintenance corrective, dans les règles de l'art.

#### **PRECAUTION D'UTILISATION**

Eviter l'utilisation improprie et non conforme au produit. D'éventuelles alterations ou installations non correspondantes aux instructions du producteur peuvent invalider les conformités préétablies du produit

EN)

## product details

trade name: **L**

type: flight with straight and fan-shaped treads, flight rotation

### used materials

#### STRUCTURE

##### description

composed of metal supports (1) assembled between themselves by bolts

##### materials

metal supports: Fe 370

plastic covers (2): polypropylene and ABS

##### finishing

supports: oven varnishing with epoxy powders

#### TREADS

##### description

straight treads (3) in solid beech, fan-shaped assembled to the structure by bolts

##### materials

birch plywood, HPL

#### RAILING

##### description

composed of vertical metal balusters (4) fixed to the treads (3) and of a PVC handrail (5)

##### materials

balusters: Fe 370

handrail: PVC with aluminium core

fixings (6) (7): nylon

##### finishing

balusters: oven varnishing with epoxy powders

#### OBLIGATORY CLEANING AND MAINTENANCE

Clean the treads as soon as dirt spots and dust deposits appear and at least every 6 months using a soft cloth moistened with water and specific non-abrasive and non-aggressive detergents. NEVER use abrasive scourers. After cleaning, thoroughly dry the surfaces with a microfibre cloth to remove the haloes that form because of the limestone in the water. Approximately 12 months from the date of installation, check tightness of the screws of the various components. Should even the smallest malfunction occur, it is obligatory to immediately and professionally carry out extraordinary maintenance.

#### USE PRECAUTION

Avoid any improper use that is not in accordance with the product. Possible violations or installations which don't comply with the providers instructions can invalidate the agreed product conformities.

DE)

## Produkteigenschaften

kommerzielle Bezeichnung: L

Typologie: Mittelholmtreppe mit geraden und fächerförmigen angeordnete Stufen, Wenedelung der Treppenläufe

### verwendete Materialien

#### STRUKTUR

##### Beschreibung

bestehend aus Metallunterkonstruktionsteilen (1), die anhand von Bolzen miteinander verbunden werden

##### Materialien

Metallunterkonstruktionsteile: Fe 370

Abdeckungen (2): aus Polypropylen und ABS

##### Ausführung

Unterkonstruktionsteile: Pulverbeschichtung mit Epoxydharzen

#### STUFEN

##### Beschreibung

gerade und fächerförmige Stufen (3), die an der Struktur mittels Bolzen befestigt sind

##### Materialien

Mehrschichtbirkenholz, HPL

#### GELÄNDER

##### Beschreibung

bestehend aus senkrechten Geländerstäben (4) aus Metall, die an den Stufen (3) und am PVC-Handlauf (5) befestigt sind

##### Materialien

Geländerstäbe: Fe 370

Handlauf: PVC mit Aluminiumkern

Befestigungen (6) (7): Nylon

##### Ausführung

Geländerstäbe: Pulverbeschichtung mit Epoxydharzen

#### REINIGUNG UND VORGESCHRIBENE INSTANDHALTUNG

Die Treppe sofort reinigen wenn Schmutzfl ecken und Staubansammlungen entstehen und sie mindestens alle 6 Monate mit einem weichen, mit Wasser und einem spezifischen, weder scheuernden, noch aggressiven Reinigungsmittel befeuchteten Lappen abzuwischen. NIEMALS scheuernde Eisenschwämme verwenden. Nach der Feuchtreinigung mit einem Mikrofasertuch sorgfältig nachtrocknen, um die Schlierenbildung durch kalkhaltiges Wasser zu vermeiden. 12 Monate nach der Montage das Anzugsmoment der Schrauben der verschiedenen Komponenten kontrollieren. Bei Auftreten einer noch so geringen Funktionsstörung muss unbedingt sofort eine fachgerechte außerordentliche Instandhaltung durchgeführt werden.

#### VORSICHTSMAßNAHMEN FÜR DIE ANWENDUNG

Die falsche und unangemessene Verwendung des Produkts vermeiden. Eventuelle Beschädigungen oder nicht der Montageanleitung des Herstellers gemässe Einrichtungen können die vorgegebene Produktkonformität für ungültig erklären.

ES)

## datos de identificación del producto

denominación comercial: **L**

tipo: escalera abierta con peldaños rectilíneos, en abanico y rotación de los tramos

### materiales empleados

#### ESTRUCTURA

##### descripción

compuesta por soportes (1) metálicos ensamblados unos con otros mediante pernos

##### materiales

soportes metálicos: Fe 370

tapas embellecedoras (2): polipropileno y ABS

##### acabado

soportes metálicos: barnizado en horno con polvos epoxídicos

#### PELDAÑOS

##### descripción

peldaños (3) rectilíneos y en abanico, ensamblados a la estructura mediante pernos

##### materiales

multicapa de abedul, HPL

#### BARANDILLA

##### descripción

compuesta por barrotes (4) verticales de metal fijados a los peldaños (3) y por un pasamanos (5) de PVC

##### materiales

barrotes: Fe 370

pasamanos: PVC con alma de aluminio

fijaciones (6) (7): nylon

##### acabado

barrotes: barnizado en horno con polvos epoxídicos

#### LIMPIEZA Y MANTENIMIENTO OBLIGATORIO

Realizar la limpieza de la escalera en cuanto aparezcan manchas de suciedad y depósitos de polvo, y periódicamente al menos cada 6 meses, con un paño suave humedecido en agua y detergentes específicos no abrasivos ni agresivos. NO utilizar nunca lanas abrasivas o de hierro. Limpiar y secar bien después del lavado utilizando un paño de microfibra para eliminar las aureolas de cal dejadas por el agua. Transcurridos unos 12 meses desde la fecha de instalación, comprobar que los tornillos que fijan las distintas partes sigan bien apretados. Ante el menor defecto de funcionamiento, es obligatorio realizar un mantenimiento extraordinario según las reglas del arte.

#### PRECAUCIONES DE USO

Evitar usos impropios y no conformes con el producto. Eventuales manipulaciones o instalaciones que no cumplan con las instrucciones del fabricante pueden menoscabar las cualidades certificadas en las pruebas de conformidad a las que previamente fue sometido el producto.

NL)

## kenmerkende productgegevens

commerciële benaming: **L**

typologie: open trap met rechte en kwartrond opgestelde treden en draaiing van de trapgedeelten

### gebruikte materialen

#### STRUCTUUR

##### beschrijving

bestaande uit stalen dragers (1) die onderling geassembleerd zijn door schroeven en moeren

##### materiaien

stalen dragers: Fe 370

afsluitdoppen (2): polypropyleen en ABS

##### afwerking

draggers: in oven uitgeharde epoxy-poeder coating

#### TREDEN

##### beschrijving

treden (3) in een rechte en kwartronde configuratie die aan de structuur bevestigd zijn door schroeven en moeren

##### materiaien

berkenfineer, HPL

#### TRAPLEUNIG

##### beschrijving

bestaande uit verticale spijlen (4) die aan de treden (3) zijn bevestigd en PVC trapleuning (5)

##### materiaien

spijlen: Fe 370

trapleuning: PVC met aluminium kern

bevestigingsmateriaal (6) (7): nylon

##### afwerking

spijlen: in oven uitgeharde epoxy poedercoating

#### REINIGING EN VERPLICHT ONDERHOUD

Maak de ladder met een zachte doek bevochtigd met water en specifieke, niet-schurende en niet-agressieve reinigingsmiddelen schoon zodra de eerste vlekken en stofophoping zich voordoen. Verricht deze handeling elke 6 maanden. GEEN metaal- of schuurspoonsjes gebruiken. Na de reiniging schoonmaken en zorgvuldig met een microvezeldoek drogen om alle kalkvlekken te verwijderen. Controleer, na ongeveer 12 maanden na de installatiedatum, of het schroefwerk van de verschillende onderdelen nog goed vastzit. Verricht bij het kleinste gebrek onmiddellijk het buitengewone onderhoud volgens de technische normen.

#### VOORZORGSMATREGELLEN

Vermijd onjuist en ongeschikt gebruik van het product. Eventuele handelingen of installaties die niet volgens de aanwijzingen van de producent zijn uitgevoerd, kunnen de vooraf bepaalde conformiteit van het product wijzigen.

## SV)

### produktens identifieringsdata

kommersiell benämning: **L**

typ: öppen trappa med raka trappsteg, spiraltrappa och av rotationstyp

#### konstruktionsmaterial

##### STRUKTUR

###### beskrivning

består av metallstöd (1) som sitter ihop med varandra med bultar

###### material

metallstöd: Fe 370

stängningslock (2): polypropylen och ABS

###### ytbehandling

stöd: ugnslackerade med epoxipulver

##### TRAPPSTEG

###### beskrivning

trappsteg (3) av typ rak eller spiralformad, monterade på stommen med bultar

###### material

björkplywood, HPL

##### RÄCKE

###### beskrivning

bestående av vertikala stolpar (4) av metall som sitter fast på trappstegen (3) och en ledstång (5) av PVC

###### material

stolpar: Fe 370

ledstång: PVC med aluminiumkärna

fästanordningar (6) (7): nylon

###### ytbehandling

stolpar: ugnslackerade med epoxipulver

#### NÖDVÄNDIG RENGÖRING OCH UNDERHÅLL

Rengör trappan vid första smutsfläck eller när damm samlas, och regelbundet minst var 6:e månad. Rengör med en trasa fuktad med vatten och lämpligt rengöringsmedel som inte är slipande eller frätande. Använd aldrig slipande svampar eller stålull. Rengör och torka noggrant efter rengöring med en mikrofiberduk för att undvika kalkfläckar från vattnet. Kontrollera åtdragningen av skruvarna för de olika komponenterna efter 12 månader. Vid varje typ av felfunktion är det obligatoriskt att utföra ett extra underhåll. Detta ska utföras omedelbart och på ett yrkesmannamässigt sätt.

#### ANVÄNDNINGSFÖRESKRIFTER

Undvik att använda produkten på ett olämpligt sätt. Eventuell mixtring eller installation som inte överensstämmer med tillverkarens anvisningar kan leda till att överensstämmelsekraven som har fastställts för produkten inte längre gäller.

## DA)

### produktets identifikationsdata

handelsbetegnelse: **L**

type: svingtrappe med retlinede, vifteformede trin og rotation af trappeløbene

#### brugte materialer

##### STRUKTUREN

###### beskrivelse

strukturen består af metalstøtter (1) som er sammensat med bolte

###### materialer

metalstøtter: Fe 370

låg (2): ABS polypropylen

###### finish

støtter: malet i ovn med epoxypulver

##### TRIN

###### beskrivelse

trin (3) retlinet vifteformet sammensat til strukturen med bolte

###### materialer

flerlags birk, HPL

##### GELÆNDER

###### beskrivelse

gelænderet består af små lodrette metalstolper (4) fikseret til trinene (3) og en håndliste i PVC (5)

###### materialer

små stolper: Fe 370

håndliste: PVC med den indvendige del i aluminium

fikseringer (6) (7): nylon

###### finish

små stolper: malet i ovn med epoxypulver

#### RENGØRING OG PÅBUDT VEDLIGEHOLDELSE

Trappen skal rengøres når de første tegn på tilsmudsning og af støvaflejinger fremkommer, og i hvert fald regelmæssigt for hver 6. måned med en blød klud vædet i vand og specifikke ikke ætsende eller aggressive rengøringsmidler. Der må ALDRIG bruges skure- eller stålsvampe. Rengør og tør omhyggeligt med en mikrofiberklud efter vask for at fjerne kalkaflejingerne, der findes i vandet. Efter ca. 12 måneder fra installationsdatoen, kontrolleres fikseringen på de forskellige komponenters skruer. I tilfælde af en hvilken som helst fejlfunktion, er det påbudt at udføre en ekstraordinær vedligeholdelse, der bør udføres omgående og i overensstemmelse med bedste praksis.

#### BRUGSHENVISNINGER

Undgå at bruge produktet forkert. Eventuelle fejlgreb eller installationer, som ikke er i overensstemmelse med producentens instruktioner, kan svække produktets fastsatte egenskaber.

## NO)

### produktinformasjon

produktnavn: **L**

karakteristikk: åpen trapp med rettlinjede trappetrinn, vifteformet og roterende trappeløp

### produksjonsmaterialer

#### STRUKTUR

##### beskrivelse

sammensatt av metallstøtter (1) festet sammen med bolter

##### materialer

metallstøtter: Fe 370

plastdeksler (2): polypropylen og ABS

##### finish

støtter: ovnlakkert med epoksy pulver

#### TRAPPETRINN

##### beskrivelse

rettlinjede trinn (3) vifteformet og montert på strukturen med bolter

##### materialer

kryssfinér i bjørk, HPL

#### REKKVERK

##### beskrivelse

sammensatt av loddrette spiler i metall (4) festet i trappetrinnene (3), og en håndløper (5) i PVC

##### materialer

spiler: Fe 370

håndløper: PVC med aluminiumskjerne

fester (6) (7): nylon

##### finish

spiler: ovnlakkert med epoksy pulver

#### RENGJØRING OG NØDVENDIG VEDLIKEHOLD

Rengjør trappen straks det oppstår flekker eller støvansamlinger. Trappen må dessuten rengjøres jevnlig minst hver 6. måned med en myk klut fuktet med vann og spesielle milde rengjøringsmidler som ikke lager riper. Bruk IKKE rengjøringssvamper med slipeeffekt eller stålull. Skyll og tørk omhyggelig med en mikrofiberklut etter rengjøringen, slik at alle kalkholdige vannflekker fjernes. Kontrollerer etter ca. 12 måneder fra installasjonen, at skruene i de forskjellige komponentene er korrekte strammet. Så snart man oppdager den minste funksjonsfeil må det utføres et forskriftsmessig ekstraordinært vedlikeholdsinngrep.

#### FORHOLDSREGLER VED BRUK

Unngå uriktig og uegnet bruk av produktet. Eventuelle endringer eller innstillinger som ikke er i samsvar med produsentens anvisninger vil kunne medføre at de forhåndsdefinerte produktkonformitetene blir ugyldiggjort.

## FI)

### tuotteen tunnistetiedot

kauppanimi: **L**

tyyppi: portaat suorilla ja kiertyvillä askelmilla, porrassyöksyen kierto

### käytetyt materiaalit

#### RAKENNE

##### kuvaus

koostuu metallisista kannattimista (1), jotka kiinnitetään yhteen pulteilla

##### materiaalit

metalliset kannattimet: Fe 370

sulkutapit (2): polypropeeni ja ABS

##### viimeistely

kannattimet: maalaus uunissa epoksijauheilla

#### ASKELMAT

##### kuvaus

suorat tai kiertyvät askelmat (3) asennettu rakenteeseen pulteilla

##### materiaalit

koivuvaneri, HPL

#### KAIDE

##### kuvaus

koostuu askelmiin (3) kiinnitetyistä metallisista pystypinoista (4) sekä PVC:stä valmistetusta käsijohteesta (5)

##### materiaalit

pystypinnat: Fe 370

käsijohde: PVC ja sisäosa alumiinia

kiinnikkeet (6) (7): nailon

##### viimeistely

pystypinnat: maalaus uunissa epoksijauheilla

#### PAKOLLINEN PUHDISTUS JA YLLÄPITO

Huolehdi portaiden puhdistuksesta ensimmäisten likatahrojen tai pölyjäämien ilmestyessä sekä säännöllisin väliajoin vähintään joka 6. kuukausi liinalla, joka on kostutettu miedon hankaamattoman pesuaineen ja veden muodostamassa liuoksessa. ÄLÄ koskaan käytä hankaavia tai metallisia sienä. Puhdista ja kuivaa huolellisesti pesun jälkeen mikrokuituliinalla, jotta poistetaan vesijäämien aikaansaamat kalkkiläikät. Noin 12 kuukauden kuluttua asennuksesta tarkista, että kaikki eri osien ruuvit ja mutterit ovat tiukalla. Mikäli havaitaan pienikin toimintahäiriö, on pakollista suorittaa ennakoimaton huolto, välittömästi ja tarvittavat toimenpiteet kunnolla suorittaen.

#### KÄYTÖN VAROTOIMET

Vältä tuotteen sopimatonta käyttöä. Mahdolliset väärinkäytökset tai asennukset, jotka eivät vastaa valmistajan ohjeita, voivat aiheuttaa sen, että tuote ei vastaa sen ilmoitettuja ominaisuuksia.



L\_Lo  
D.U.M.  
02/2017

fontanot®

Fontanot S.p.A.  
**Sede legale ed amministrativa**  
via P. Paolo Pasolini, 6  
47853 Cerasolo Ausa  
Rimini, Italy

tel. +39.0541.90.61.11  
fax. +39.0541.90.61.24  
info@fontanot.it  
www.fontanot.it

cod. 067487001

Design: Centro Ricerche Fontanot

Sistema aziendale Fontanot S.p.A.  
certificato CSQ ISO-9001

