

zen



fontanot



Copyright by Fontanot S.p.A., first publication January 8, 2013



13 mm
17 mm
19 mm

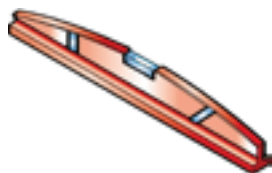

2 mm 5 mm
2,5 mm 6 mm
3 mm 8 mm
4 mm



PH 2



Ø 3,5 mm
Ø 5 mm
Ø 11 mm



Ø 8 x 120 mm
Ø 14 x 150 mm









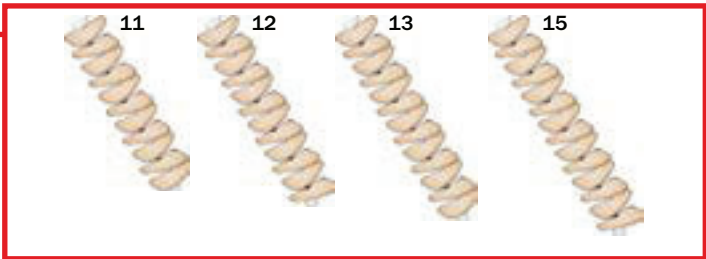
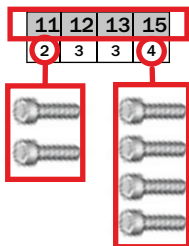





8 mm
13 mm
19 mm



8 mm



<p>A39</p>  <table border="1"> <tr><td>11</td><td>12</td><td>13</td><td>15</td></tr> <tr><td>15</td><td>15</td><td>20</td><td>20</td></tr> </table>	11	12	13	15	15	15	20	20	<p>A41</p>  <table border="1"> <tr><td>11</td><td>12</td><td>13</td><td>15</td></tr> <tr><td>10</td><td>10</td><td>15</td><td>15</td></tr> </table>	11	12	13	15	10	10	15	15	<p>B02</p>  <table border="1"> <tr><td>11</td><td>12</td><td>13</td><td>15</td></tr> <tr><td>1</td><td>1</td><td>1</td><td>1</td></tr> </table>	11	12	13	15	1	1	1	1
11	12	13	15																							
15	15	20	20																							
11	12	13	15																							
10	10	15	15																							
11	12	13	15																							
1	1	1	1																							
<p>B12</p>  <table border="1"> <tr><td>11</td><td>12</td><td>13</td><td>15</td></tr> <tr><td>3</td><td>3</td><td>3</td><td>3</td></tr> </table>	11	12	13	15	3	3	3	3	<p>B13</p>  <table border="1"> <tr><td>11</td><td>12</td><td>13</td><td>15</td></tr> <tr><td>2</td><td>2</td><td>2</td><td>2</td></tr> </table>	11	12	13	15	2	2	2	2	<p>B51</p>  <table border="1"> <tr><td>11</td><td>12</td><td>13</td><td>15</td></tr> <tr><td>2</td><td>2</td><td>2</td><td>3</td></tr> </table>	11	12	13	15	2	2	2	3
11	12	13	15																							
3	3	3	3																							
11	12	13	15																							
2	2	2	2																							
11	12	13	15																							
2	2	2	3																							
<p>B71</p>  <table border="1"> <tr><td>11</td><td>12</td><td>13</td><td>15</td></tr> <tr><td>18</td><td>20</td><td>22</td><td>26</td></tr> </table>	11	12	13	15	18	20	22	26	<p>B75</p>  <table border="1"> <tr><td>11</td><td>12</td><td>13</td><td>15</td></tr> <tr><td>36</td><td>40</td><td>44</td><td>52</td></tr> </table>	11	12	13	15	36	40	44	52	<p>B95</p>  <table border="1"> <tr><td>11</td><td>12</td><td>13</td><td>15</td></tr> <tr><td>3</td><td>3</td><td>3</td><td>3</td></tr> </table>	11	12	13	15	3	3	3	3
11	12	13	15																							
18	20	22	26																							
11	12	13	15																							
36	40	44	52																							
11	12	13	15																							
3	3	3	3																							
<p>BA4</p>  <table border="1"> <tr><td>11</td><td>12</td><td>13</td><td>15</td></tr> <tr><td>5</td><td>6</td><td>6</td><td>7</td></tr> </table>	11	12	13	15	5	6	6	7	<p>BB3</p>  <table border="1"> <tr><td>11</td><td>12</td><td>13</td><td>15</td></tr> <tr><td>8</td><td>10</td><td>10</td><td>12</td></tr> </table>	11	12	13	15	8	10	10	12	<p>BB6</p>  <table border="1"> <tr><td>11</td><td>12</td><td>13</td><td>15</td></tr> <tr><td>3</td><td>4</td><td>4</td><td>5</td></tr> </table>	11	12	13	15	3	4	4	5
11	12	13	15																							
5	6	6	7																							
11	12	13	15																							
8	10	10	12																							
11	12	13	15																							
3	4	4	5																							

BB7



11	12	13	15
10	10	10	10

BF7



11	12	13	15
5	6	6	7

BG1



11	12	13	15
30	35	35	40

BG2



11	12	13	15
3	4	4	5

BG3



11	12	13	15
3	4	4	5

BG4



11	12	13	15
8	10	10	12

BH4



11	12	13	15
3	3	3	4

C49



11	12	13	15
1	1	1	1

C50



11	12	13	15
1	1	1	1

C54



11	12	13	15
6	7	7	8

C57



11	12	13	15
45	49	53	61

C58



11	12	13	15
3	3	3	3

C76



11	12	13	15
10	10	10	10

C77



11	12	13	15
30	35	35	40

C83



11	12	13	15
6	7	7	8

CD3



11	12	13	15
12	14	14	16

CE3



11	12	13	15
5	6	6	7

CE4



11	12	13	15
1	1	1	1

CF8



11	12	13	15
18	20	22	26

D38



11	12	13	15
10	10	10	10

D40



11	12	13	15
10	10	10	10

D43



11	12	13	15
6	7	7	8

F09



11	12	13	15
1	1	1	1

F12



11	12	13	15
2	2	2	2

F20



11	12	13	15
4	4	4	4

F33



11	12	13	15
2	2	2	2

F54



11	12	13	15
1	1	1	1

L42



11	12	13	15
10	11	12	14

L43



11	12	13	15
1	1	1	1

N16



11	12	13	15
1	1	1	1

N17



11	12	13	15
1	1	1	1

N18



11	12	13	15
7	8	9	11

N19



11	12	13	15
1	1	1	1

X04





IT) ATTENZIONE!

Leggere e seguire scrupolosamente queste istruzioni e tenere per future consultazioni.

Eseguire l'installazione "a regola d'arte", utilizzando attrezzi idonei; seguire scrupolosamente le istruzioni di montaggio. Informarsi prima dell'installazione, sui regolamenti locali e nazionali da rispettare, in funzione della destinazione d'uso (privato principale, secondario, uffici, negozi,...).

EN) WARNING!

Carefully read and strictly follow these instruction and keep them for future consultation.

Carry out the installation in a "workmanlike" manner, strictly following the installation instructions and using suitable tools. Always consult your local building department for code requirements that must be respected depending on its destination of use (private, secondary, public...).

DE) ACHTUNG!

Lesen sie diese Anleitung sorgfältig durch und heben sie sie für spätere Zwecke auf.

Die Montage muss fachgerecht, unter Zuhilfenahme geeigneter Hilfsmittel und unter strikter Einhaltung der Montageanleitung ausgeführt werden. Damit die Montage normgerecht erfolgen kann, muss man zuvor Informationen zur Aufstellung und zu den lokal und national geltenden Vorschriften je nach Bestimmungszweck (privat, Haupt- oder Nebeneinrichtung, Büros, Geschäfte, ...) einholen.

FR) ATTENTION !

Lire et respecter scrupuleusement les présentes instructions ; les conserver pour toute autre consultation.

Effectuer l'installation dans les règles de l'art en utilisant des outils appropriés ; suivre scrupuleusement les instructions de montage. Pour réaliser un montage conforme aux normes en vigueur, il faut s'informer avant l'installation quant aux réglementations locales et nationales à respecter, en fonction du domaine d'utilisation (résidence privée principale, secondaire, bureaux, magasins,...).

ES) ¡ATENCIÓN!

Leer y seguir estrictamente estas instrucciones y conservarlas para consultas futuras.

Realizar la instalación "según las reglas del arte", utilizando herramientas adecuadas; seguir estrictamente las instrucciones de montaje. Informarse antes de la instalación sobre los reglamentos locales y nacionales a respetar, en función del destino de uso (privado principal, secundario, oficinas, tiendas,...).



DA) ADVARSEL!

Læs og overhold nøje disse anvisninger og opbevar dem til efterfølgende henvisninger.

Installationen skal udføres i overensstemmelse med bedste praksis, ved brug af egnede redskaber; følg omhyggeligt monteringsinstruktionerne. Hent oplysninger før installationen angående de lokale og nationale bestemmelser, der skal overholdes afhængigt af den påtænkte anvendelse (privat hovedbrug, privat sekundær brug, kontorer, butikker,....).

NO) ADVARSEL!

Les og følg bruksanvisningen nøye og oppbevar den for senere bruk.

Produktet må installeres "etter alle kunstens regler" og med passende verktøy. Følg monteringsbeskrivelsen nøye. Informer deg om eventuelle lokale og nasjonale forskrifter som gjelder for ditt spesielle bruksområde (primær eller sekundær privat bruk, kontorer, forretninger osv.) før du installerer produktet.

FI) VAROITUS!

Lue ja noudata huolellisesti näitä ohjeita ja säilytä ne tulevaa tarvetta varten.

Suorita asennus kunnolla käyttäen asianmukaisia välineitä; noudata huolellisesti asennusohjeita. Tutustu ennen asennusta voimassa oleviin paikallisiin ja kansallisiin määräyksiin, käyttökohteen mukaan (yksityinen pääasiallinen, toissijainen, toimisto, kaupat,...).

CS) VAROVÁNÍ!

Pečlivě si přečtěte a přesně dodržujte tyto pokyny a pokyny uchovejte pro pozdější použití.

Proved'te instalaci „odborným“ způsobem a přesně dodržujte pokyny pro instalaci a používejte vhodné nástroje. Vždy si zjistěte na místním stavebním úřadě, jaké jsou požadavky předpisů, které musí být dodržovány v závislosti na určeném použití (soukromý, druhotný, veřejný...).

SK) VAROVANIE!

Pozorne si prečítajte a striktné dodržiavajte tieto inštrukcie a uschovajte ich pre prípad potreby v budúcnosti.

Inštaláciu vykonajte profesionálnym spôsobom, striktné dodržiavajte nasledovné inštaláčne inštrukcie a použite vhodné nástroje. V prípade požiadavok kódov, ktoré sa musia dodržať v závislosti od miesta použitia (súkromné priestory, pomocné priestory, verejné priestory...) to vždy konzultujte so svojim miestnym stavebným oddelením.

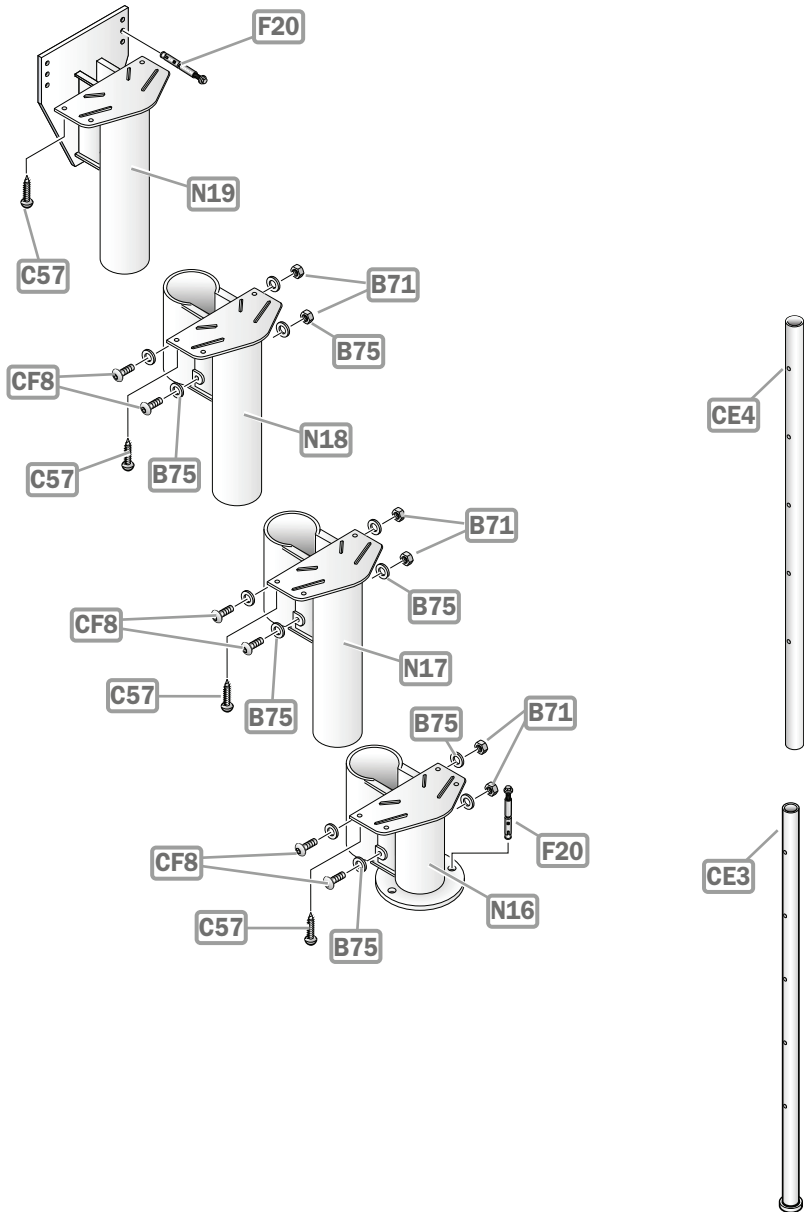

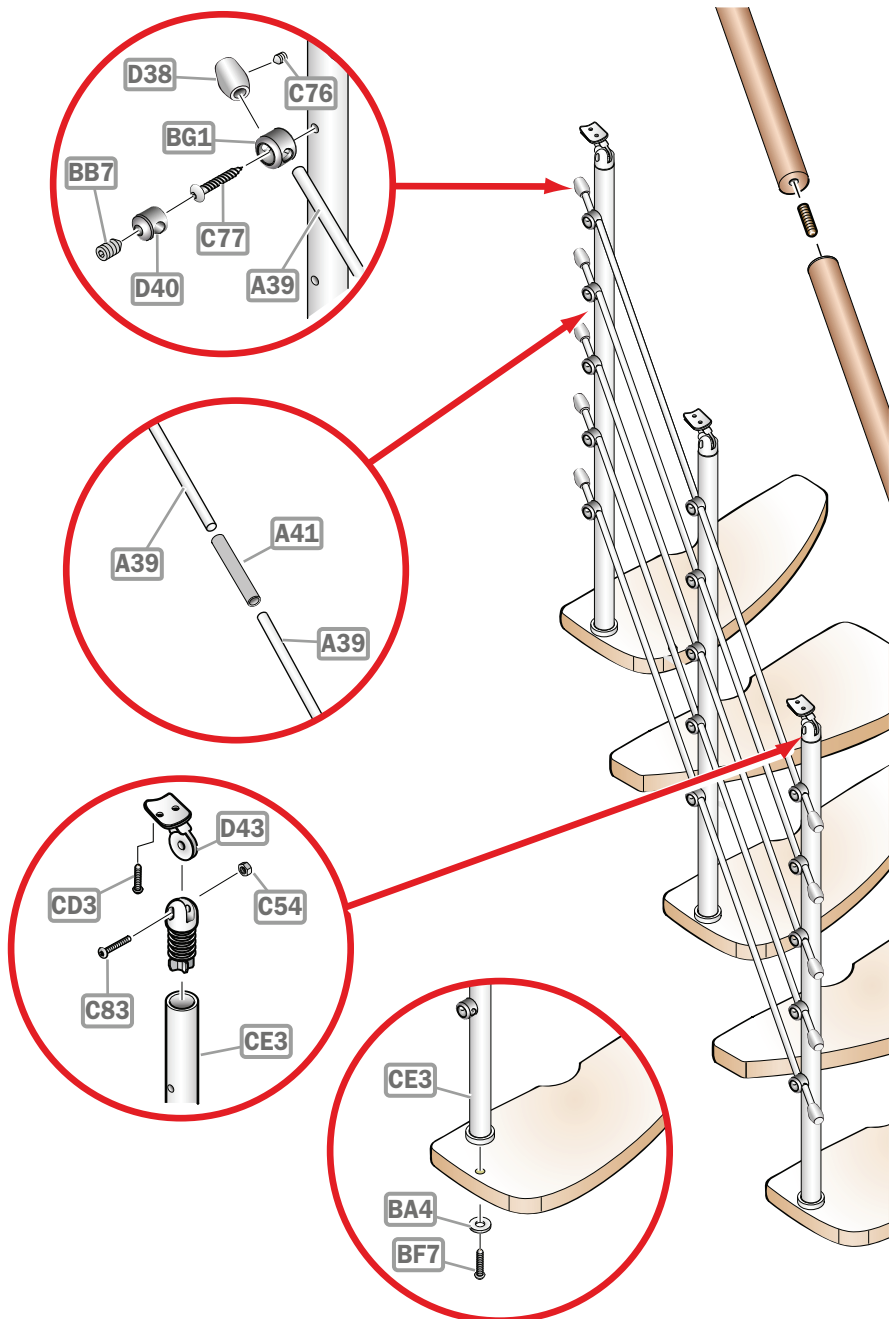

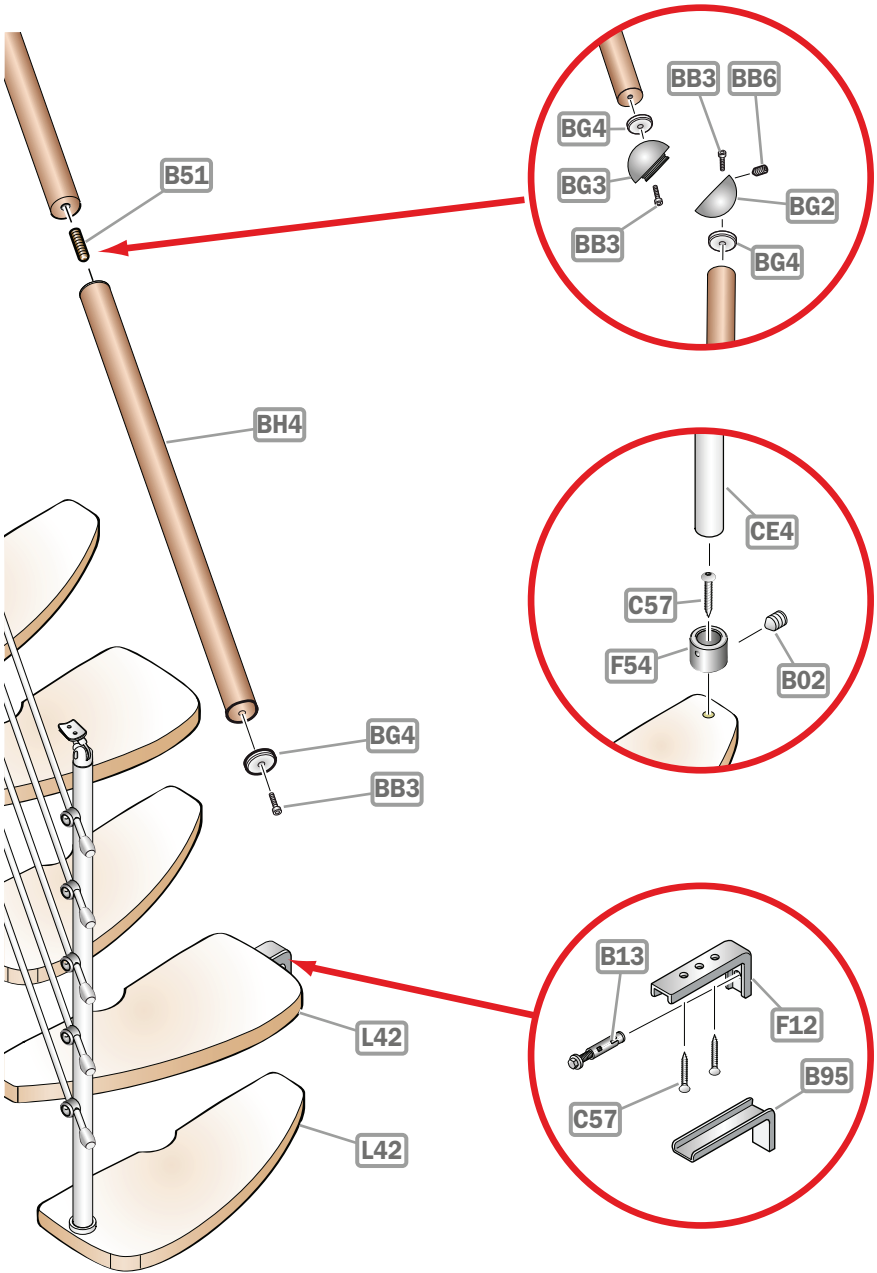

4

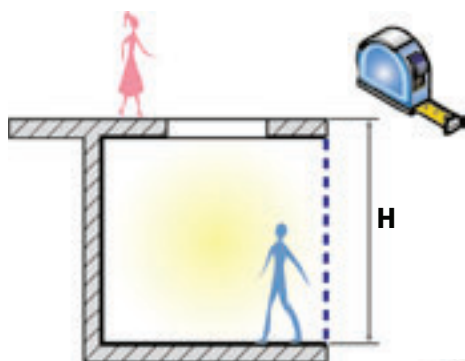
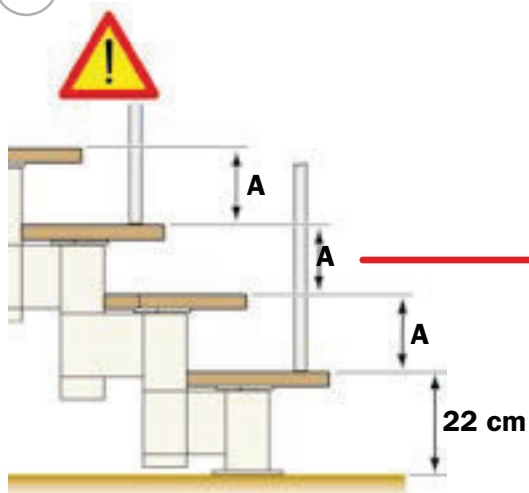

11 (N) → H = 212 ÷ 257 cm

12 (N) → H = 231 ÷ 280 cm

13 (N) → H = 250 ÷ 304 cm

15 (N) → H = 288 ÷ 351 cm



18 - 22

11 (N)

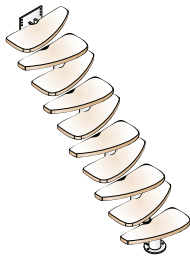

12 (N)

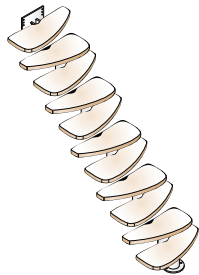

13 (N)

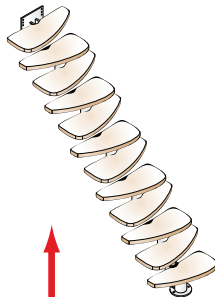

15 (N)

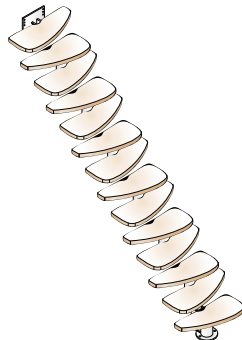

$$A = H - 22 \text{ cm} / N - 1$$

$$(A = 19 \div 23,5 \text{ cm})$$

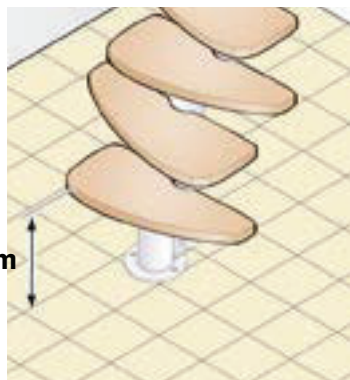
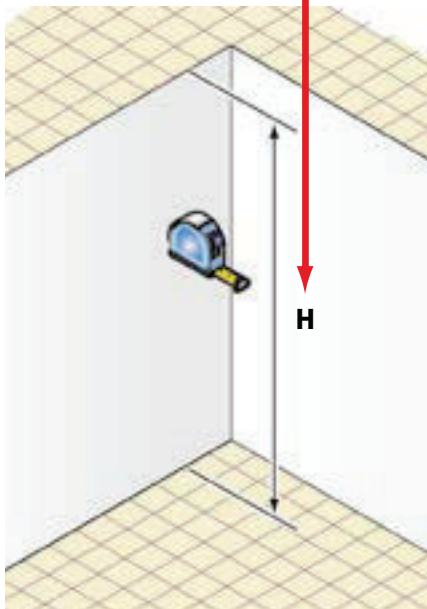

5

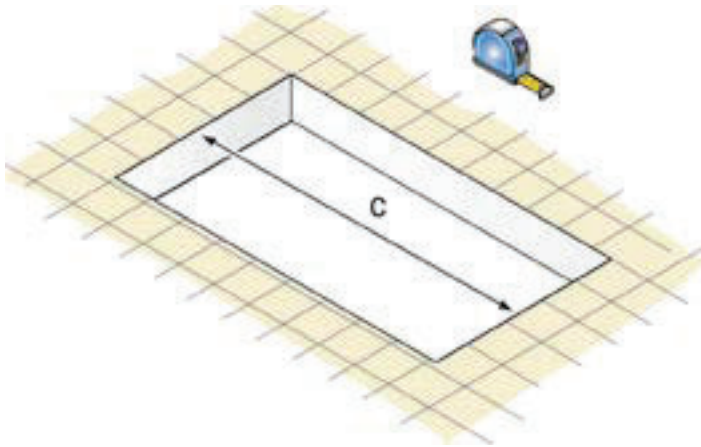

6 a

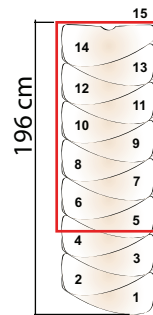
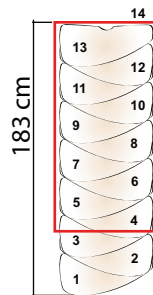
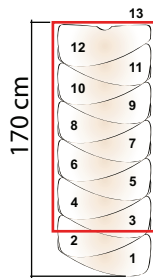
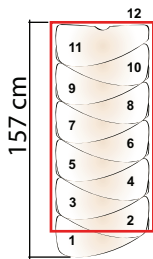
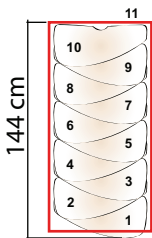
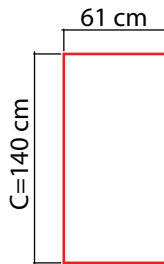

6 b

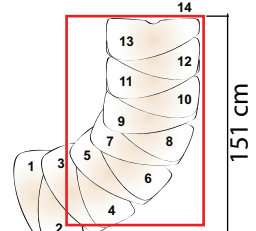
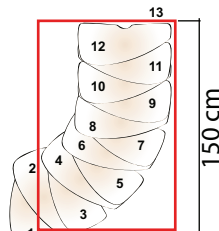
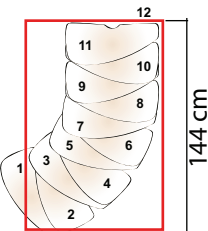
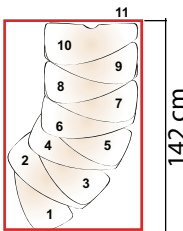
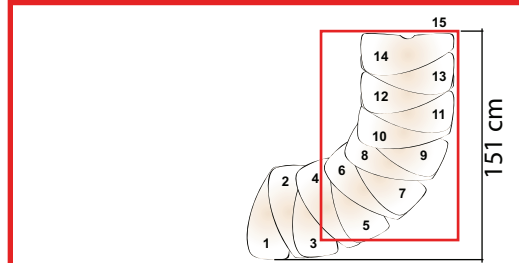
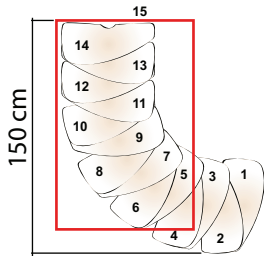
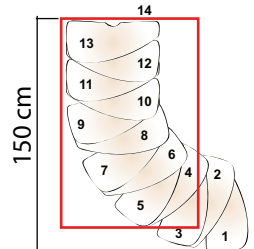
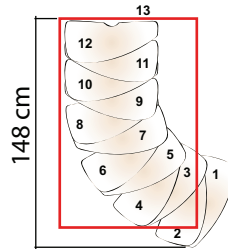
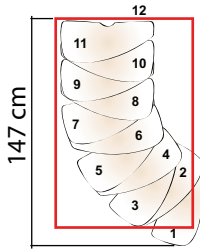
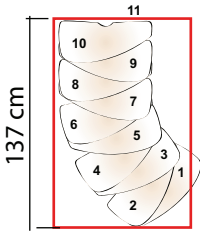
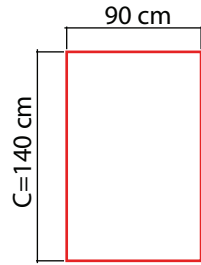
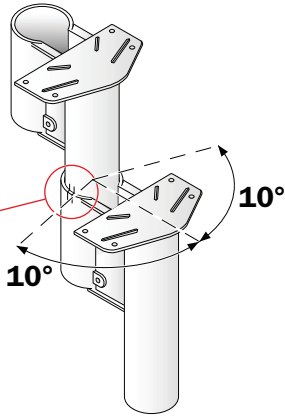
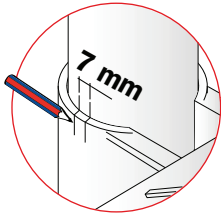

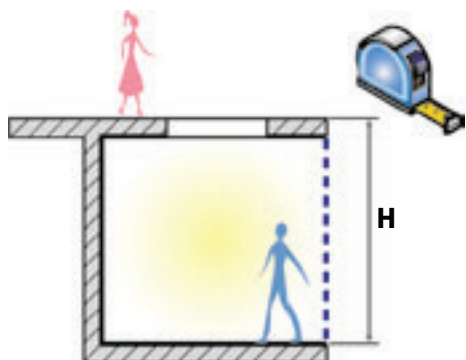

$$H = 212 \div 257 \text{ cm}$$

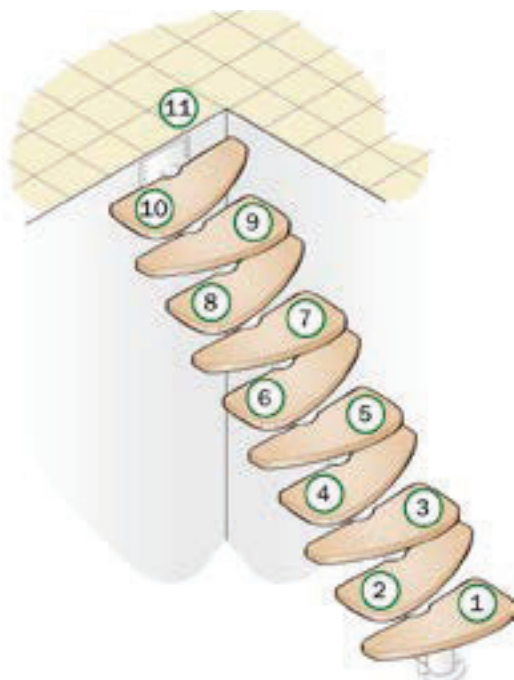
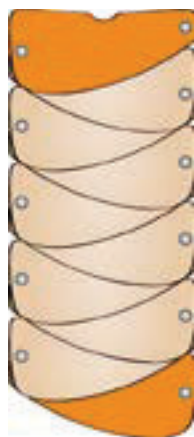

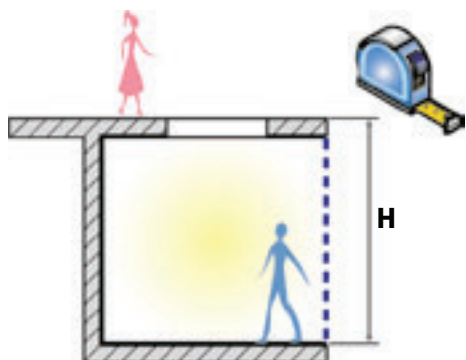

$$H = 231 \div 280 \text{ cm}$$

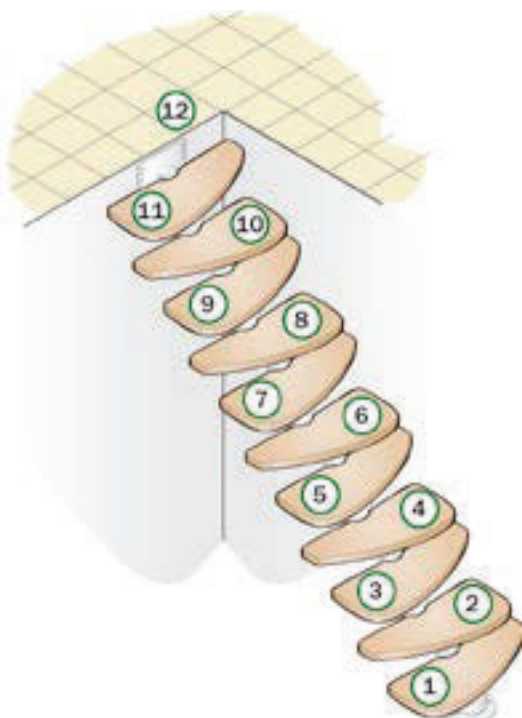

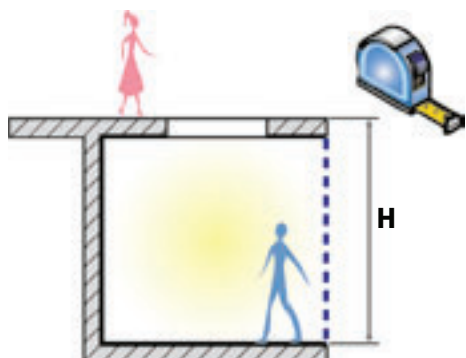

$$H = 250 \div 304 \text{ cm}$$

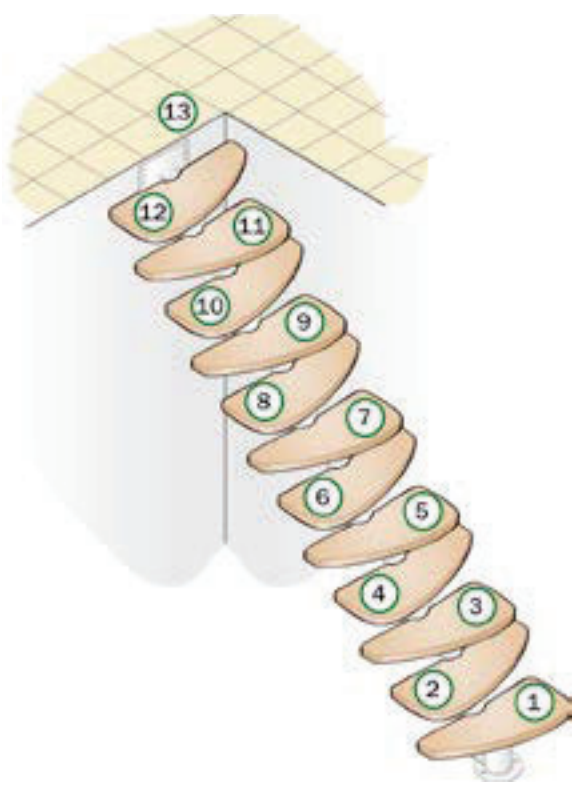

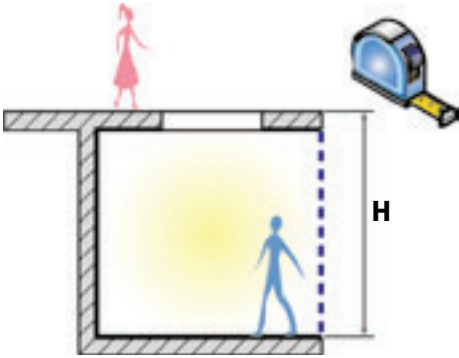

$$H = 269 \div 327 \text{ cm}$$

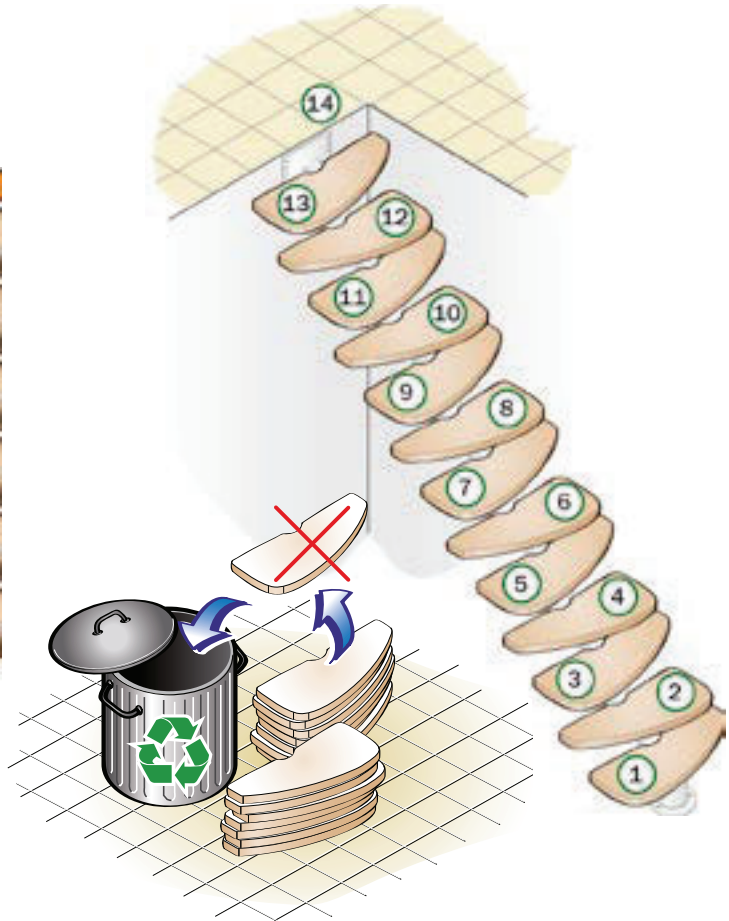
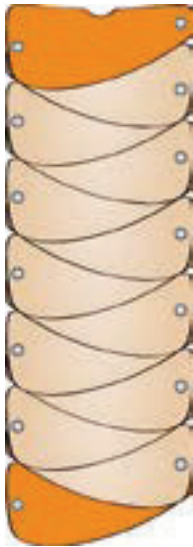

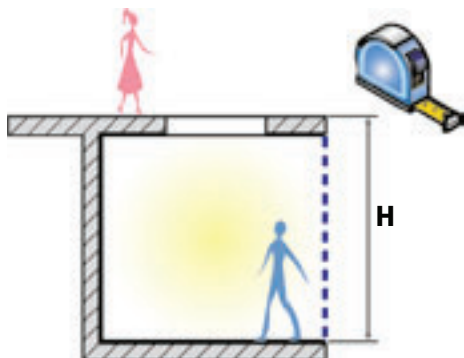

$$H = 269 \div 327 \text{ cm} \quad (14)$$

$$H = 288 \div 351 \text{ cm} \quad (15)$$

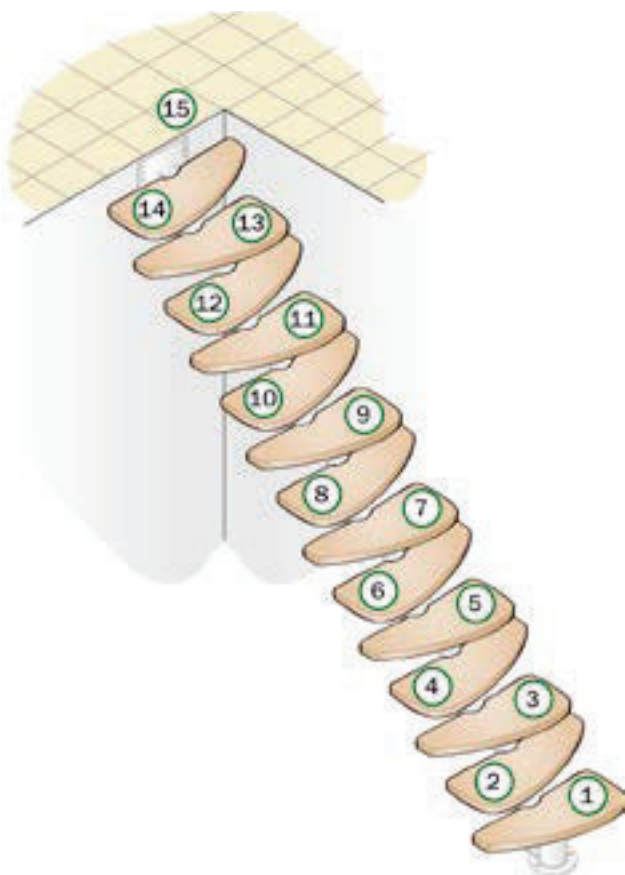
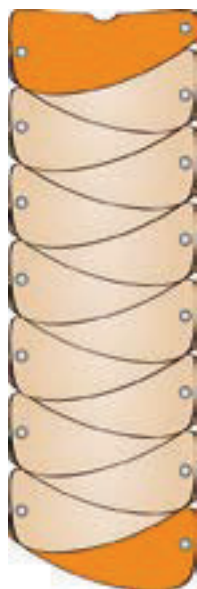

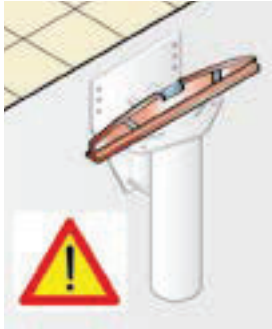

$$Q = A + 3,5 \text{ cm}$$

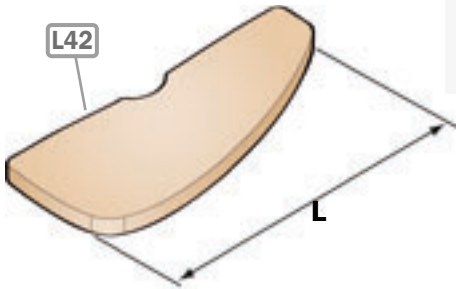
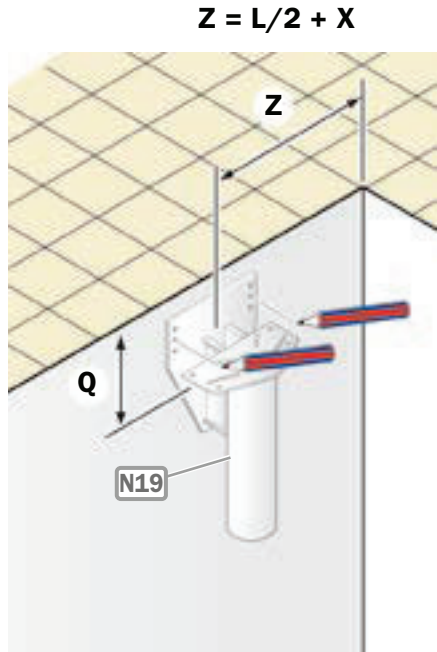

$$X = 2 \div 6 \text{ cm}$$

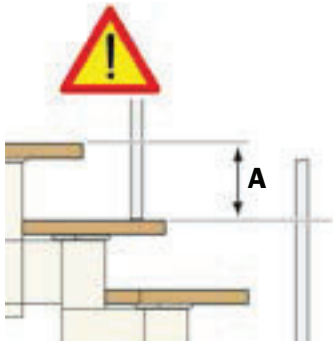
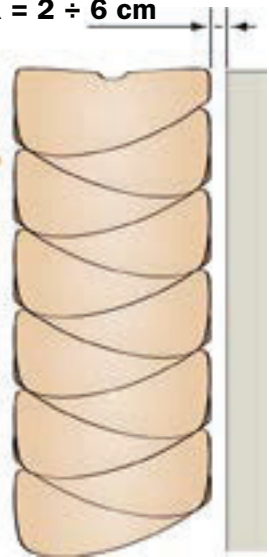

7

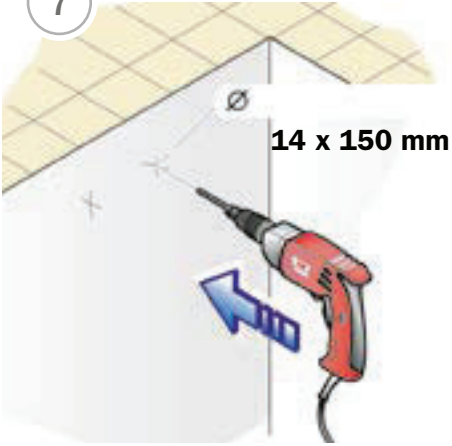

8

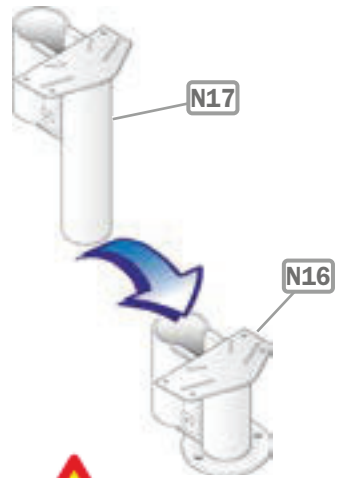

9

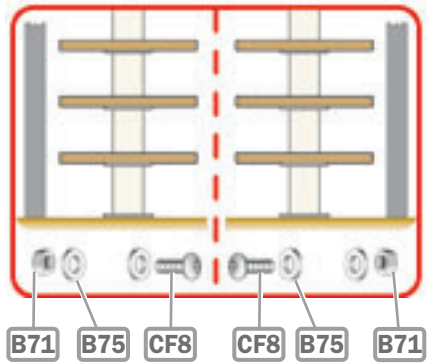
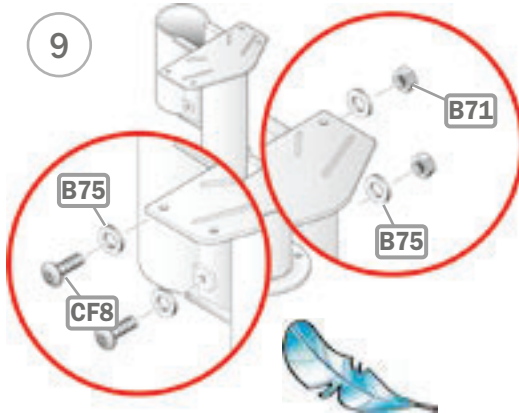

10



11

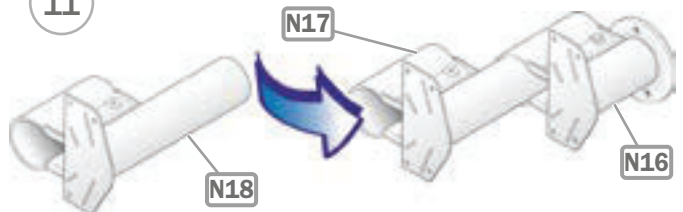

12

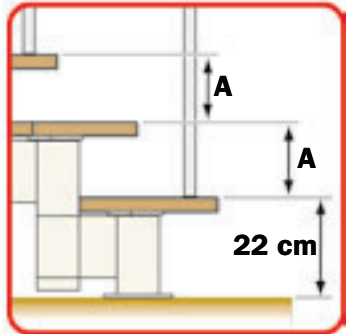
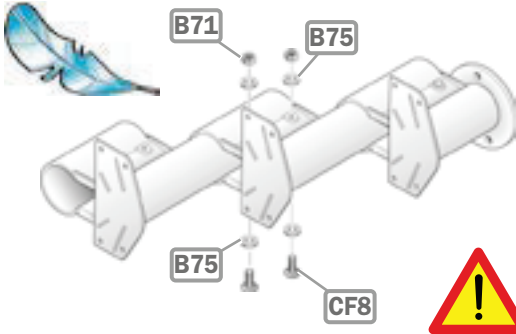

13

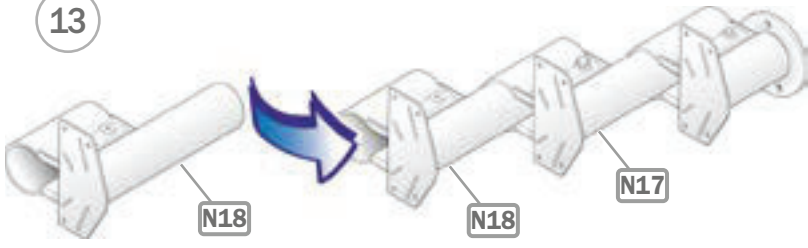

14

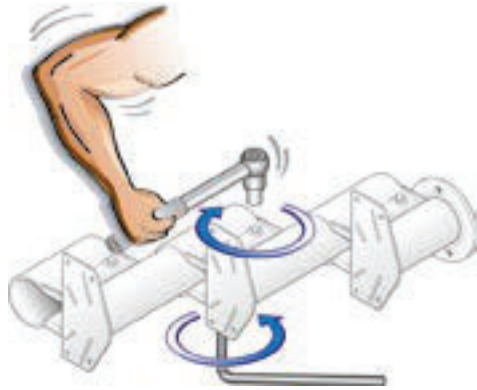

15

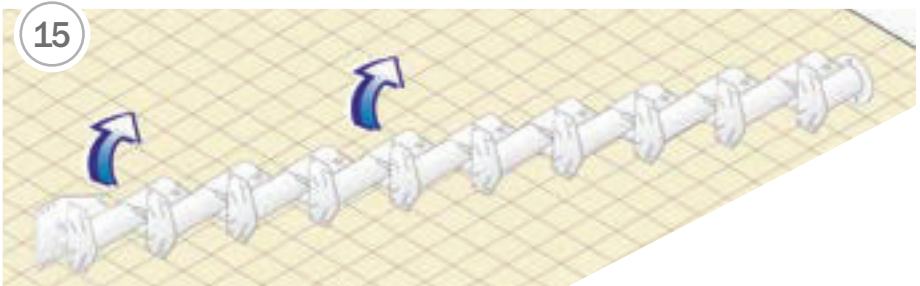

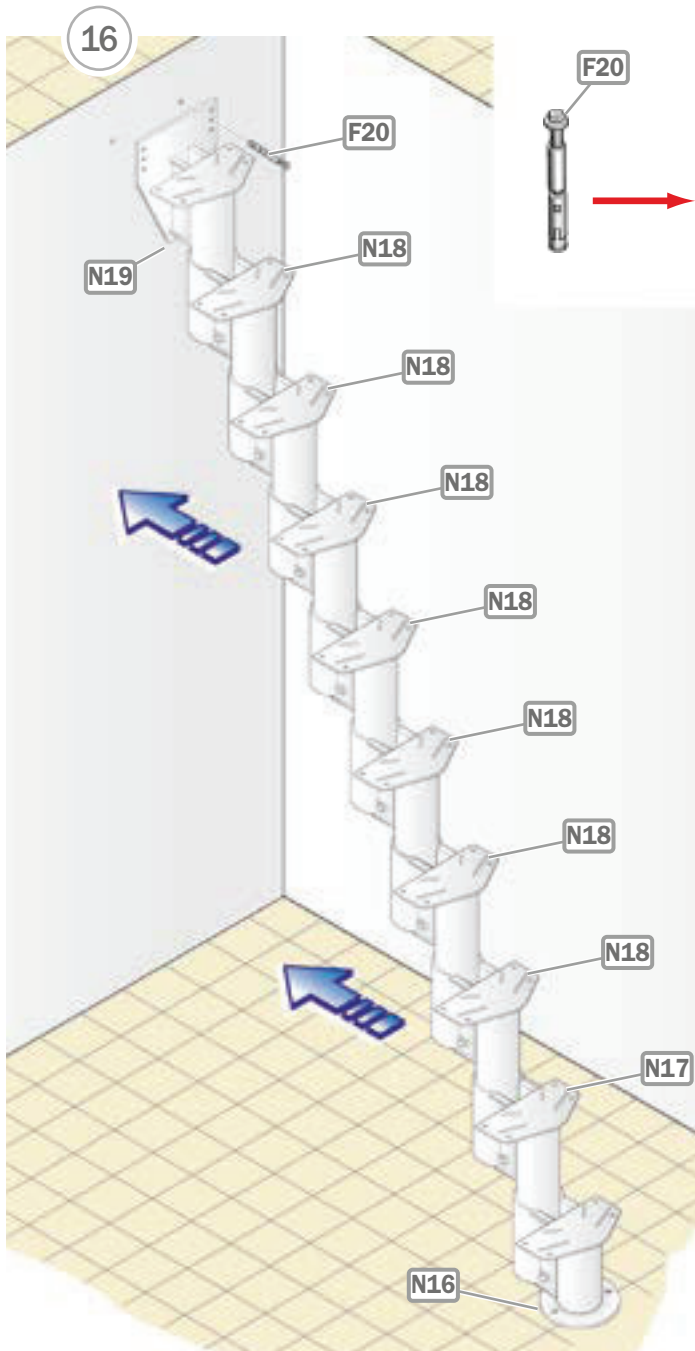

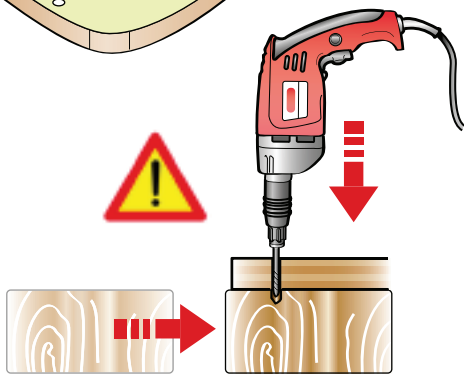
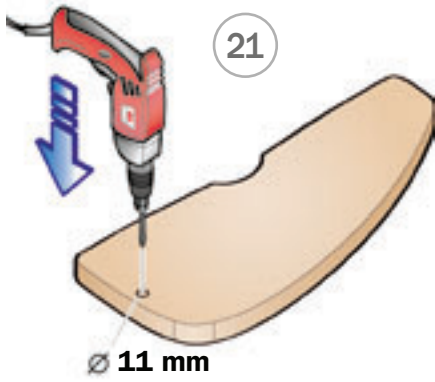
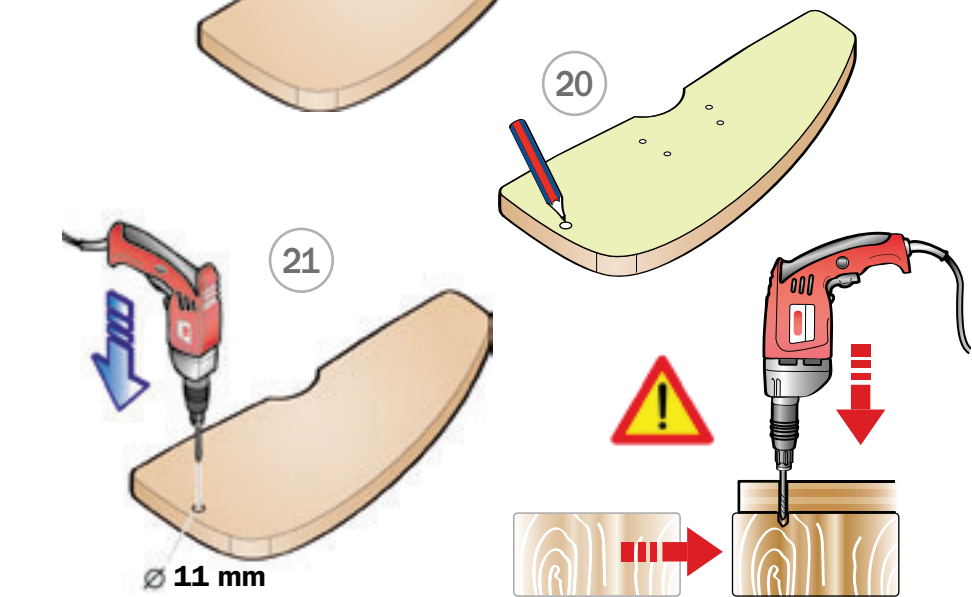
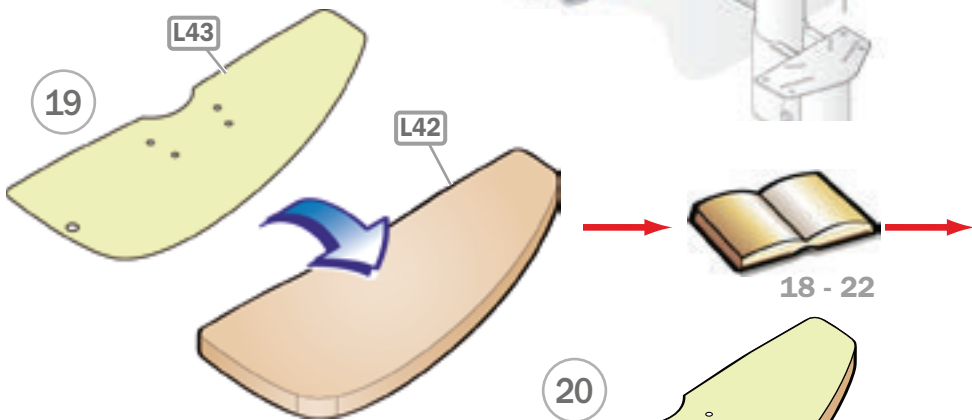
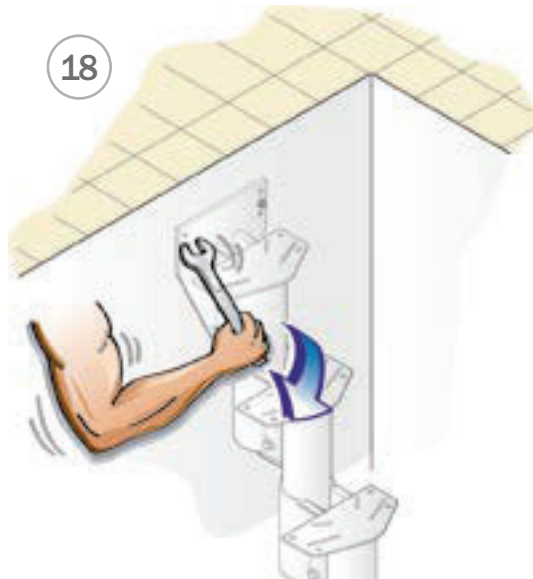
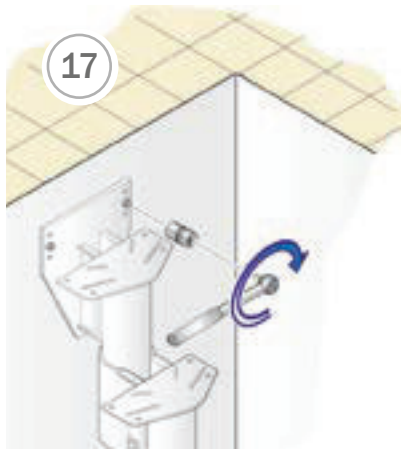

22 - b

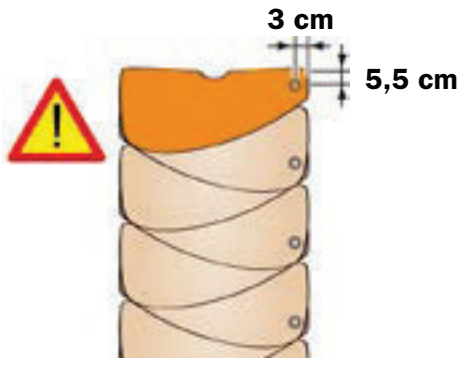
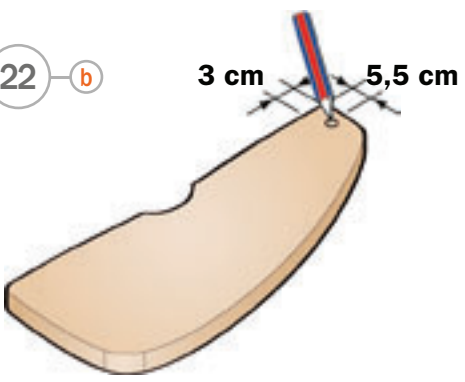

23 - b

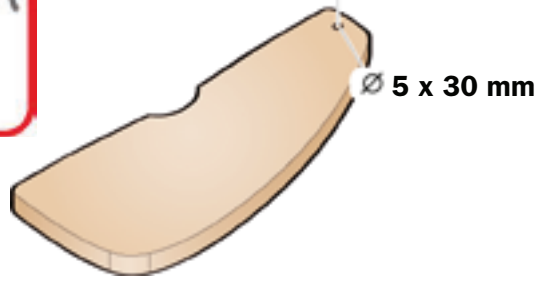
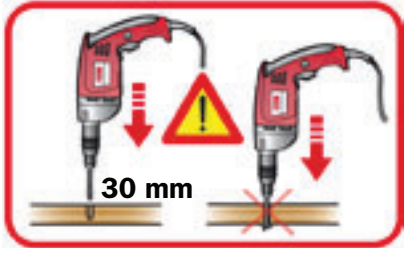

24

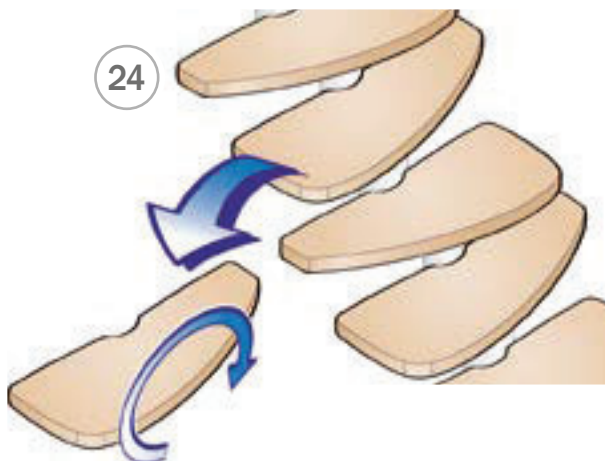

25

L43

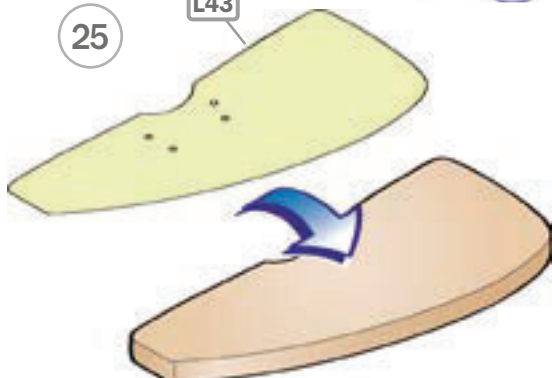

26

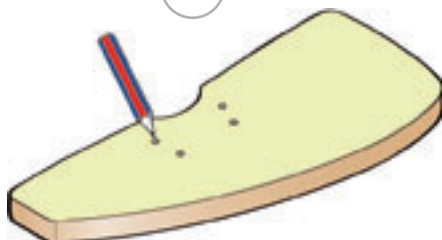

27

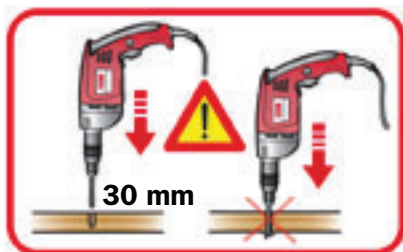
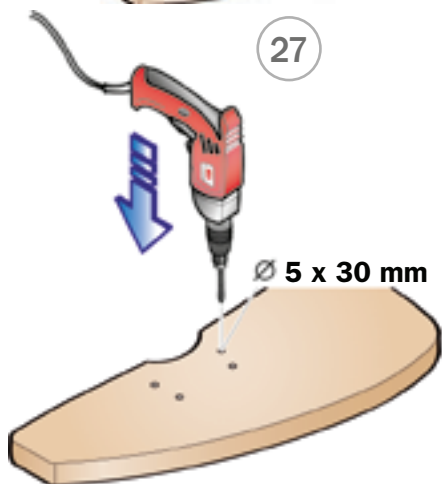

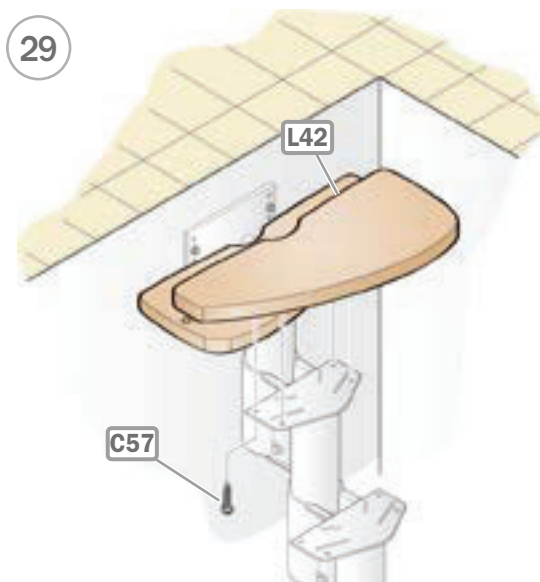
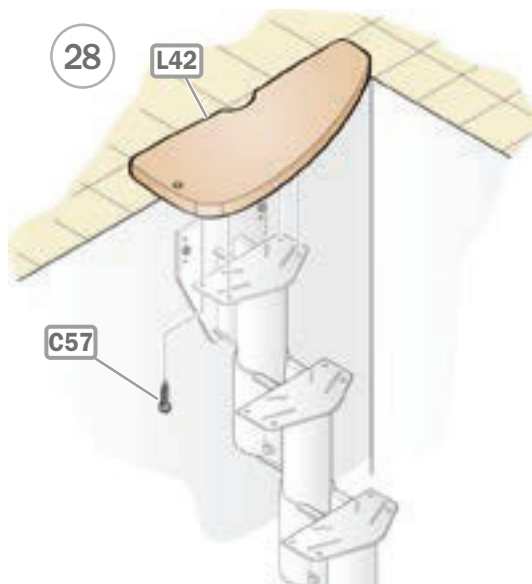

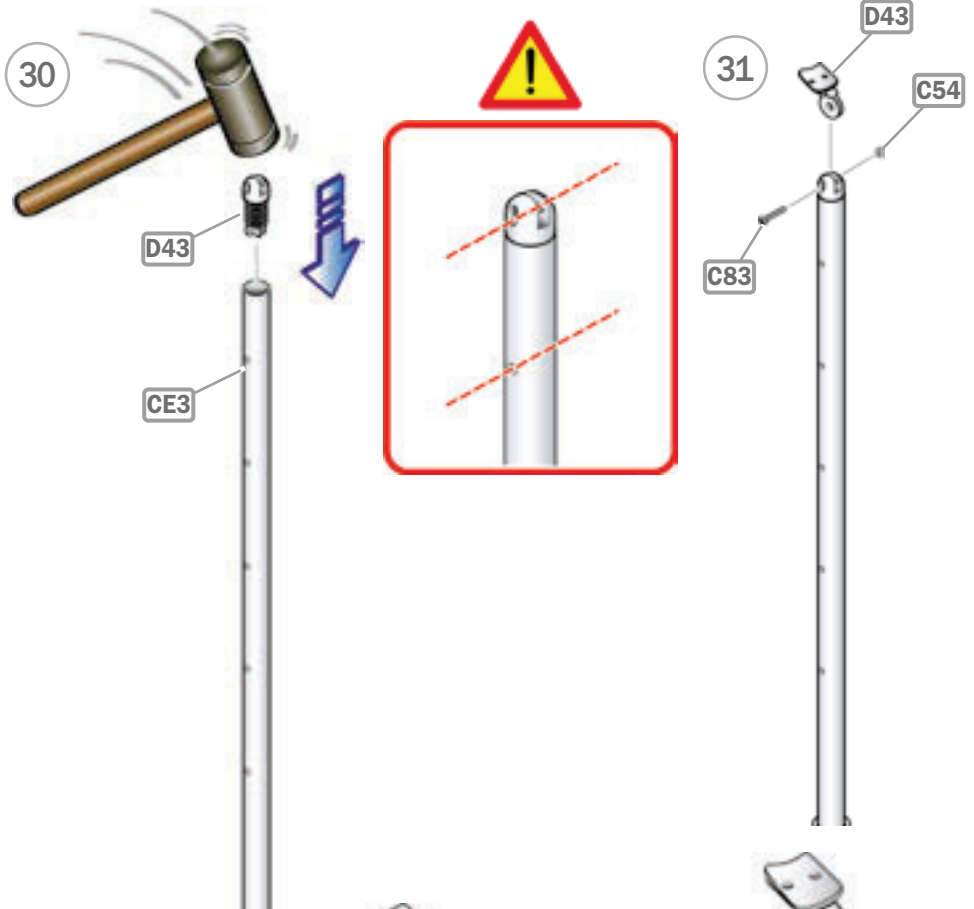

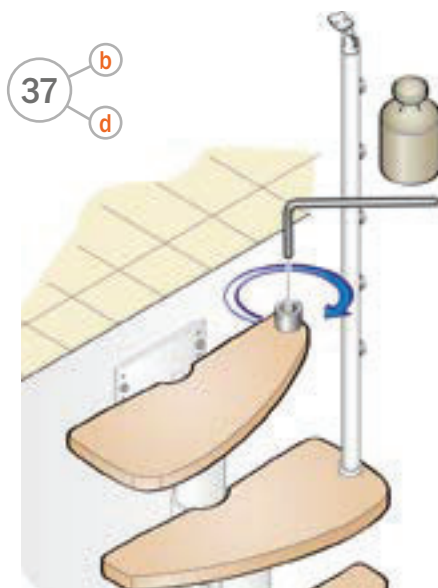
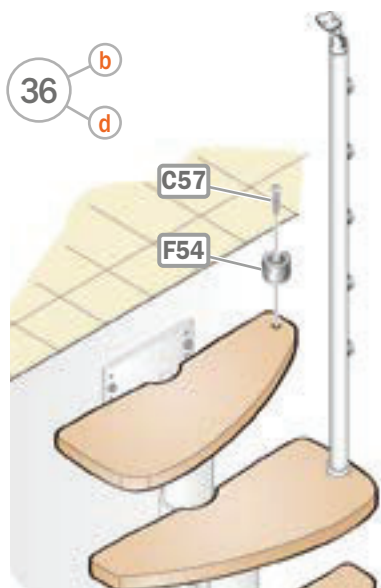
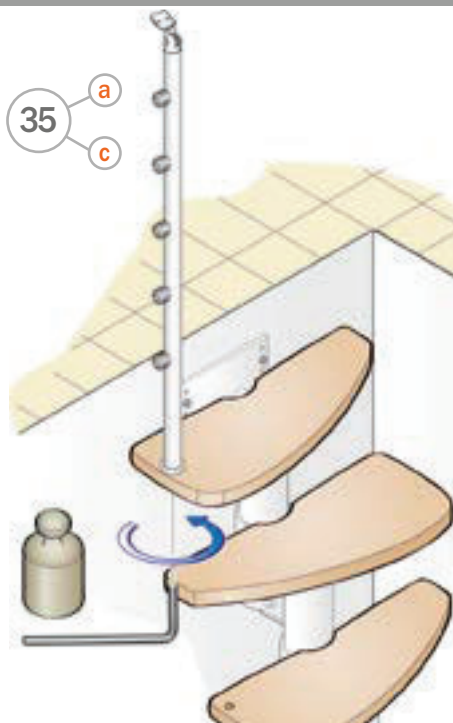
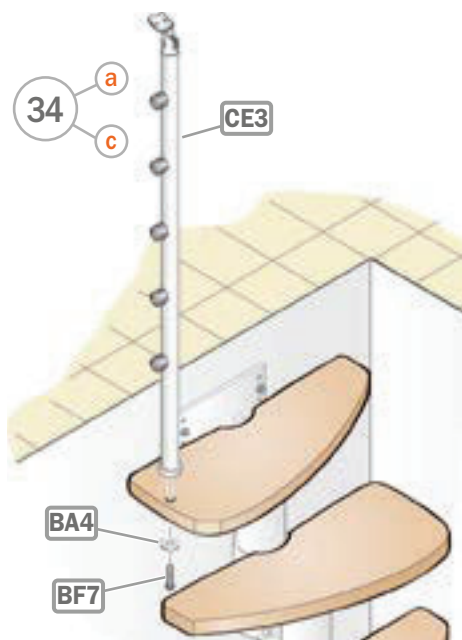

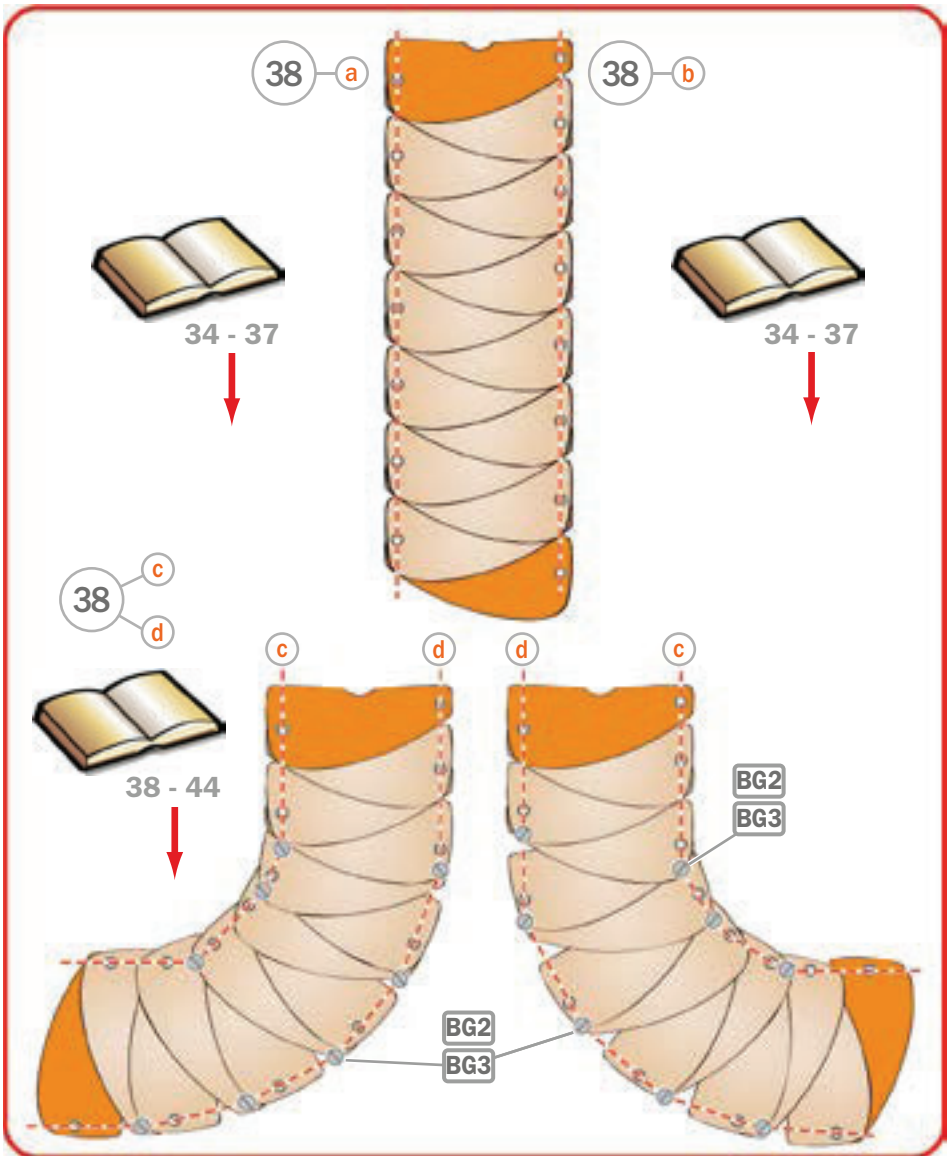

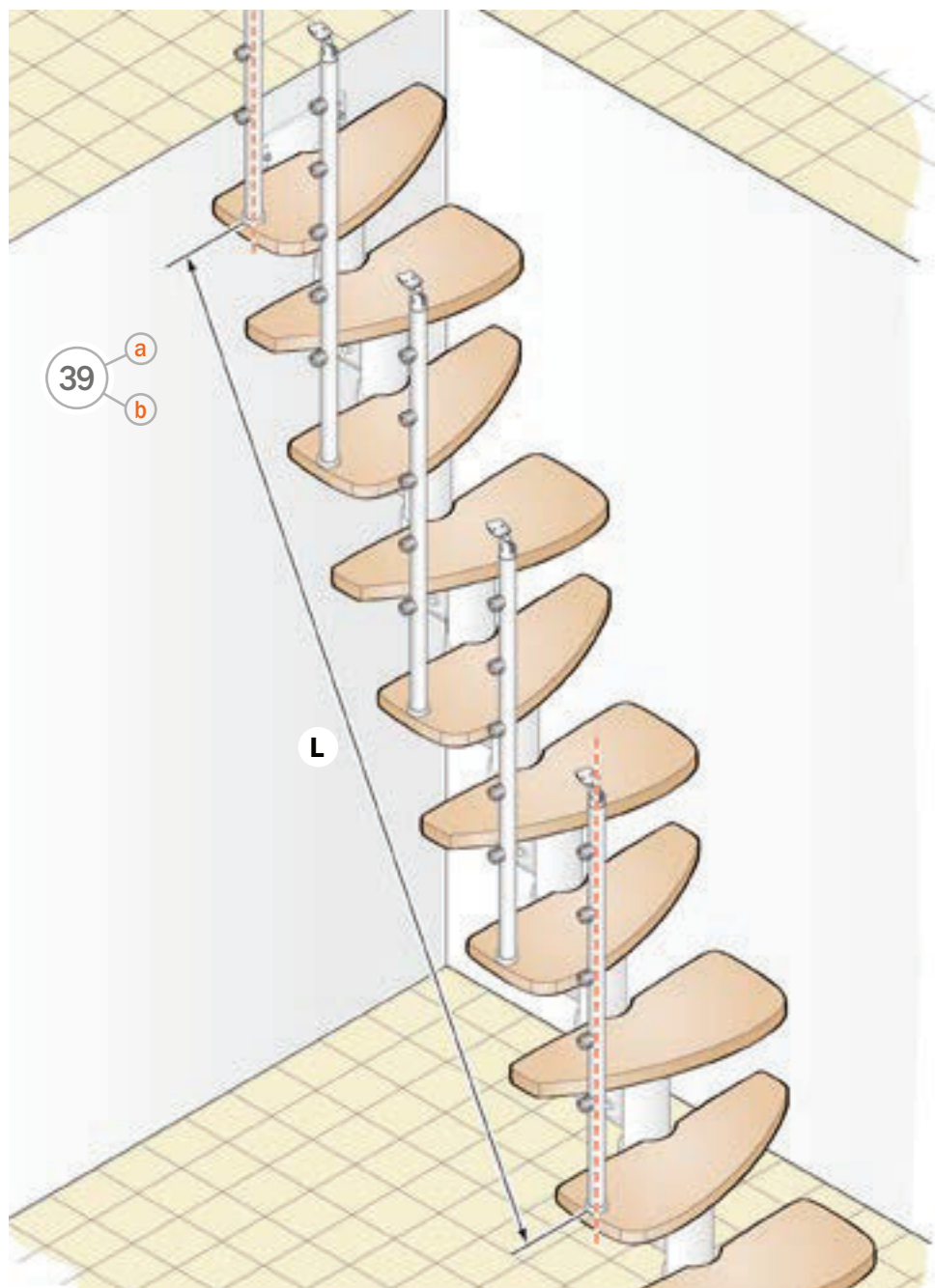

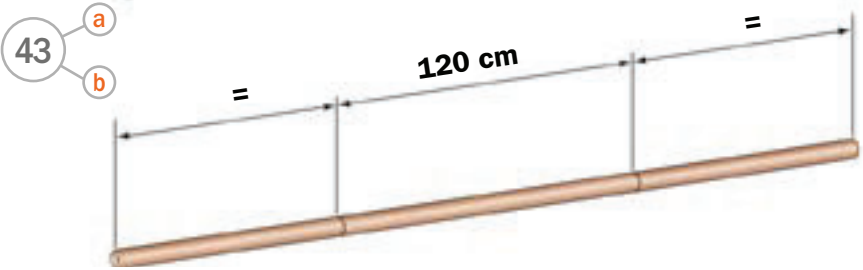
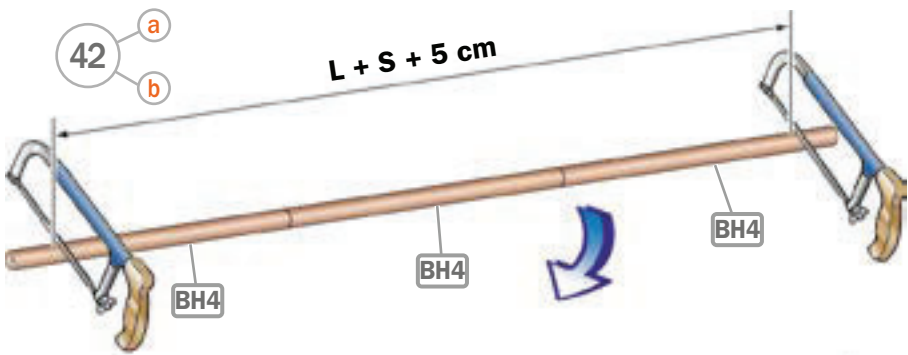
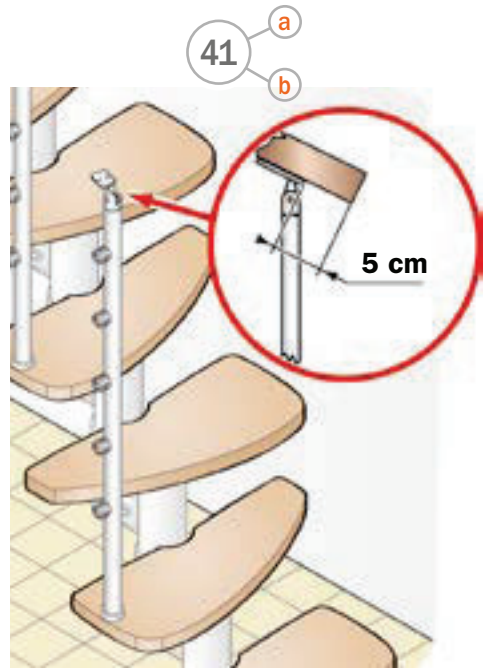
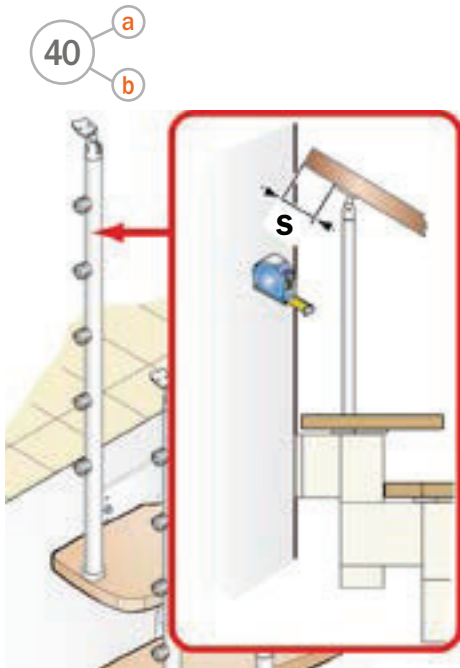

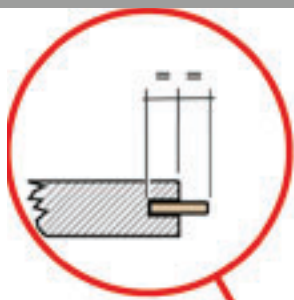

44
a
b

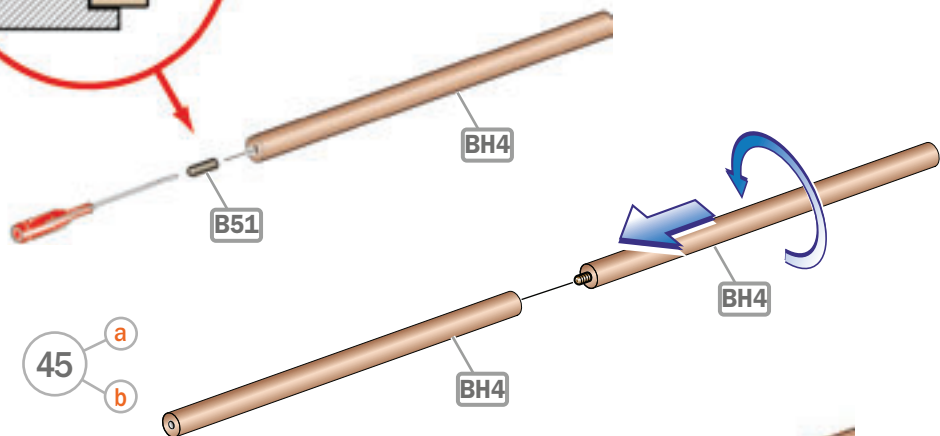

45
a
b



46
a
b



47
a
b



48
a
b

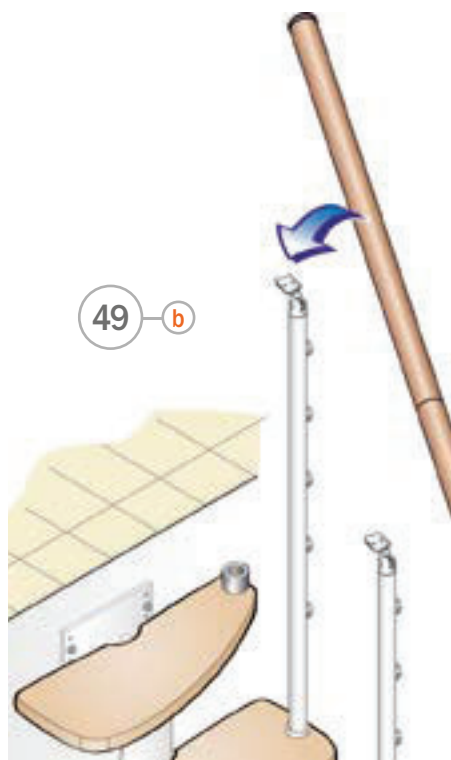
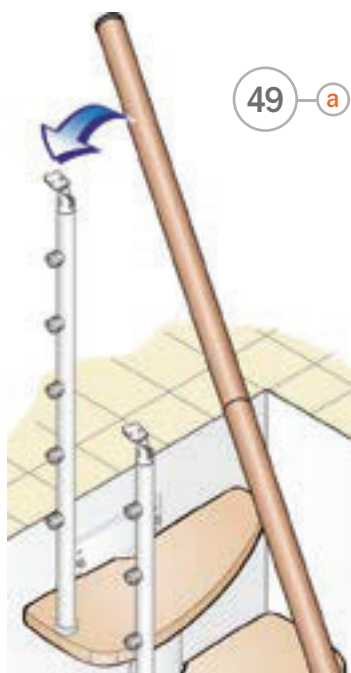

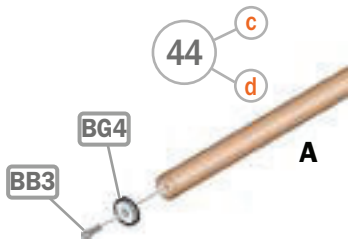
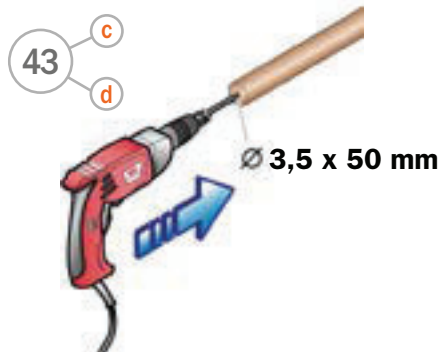
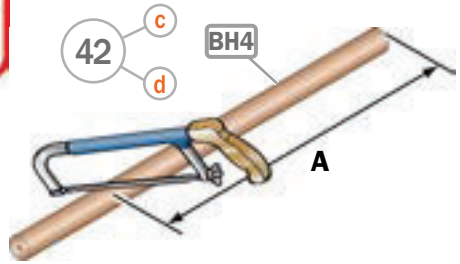
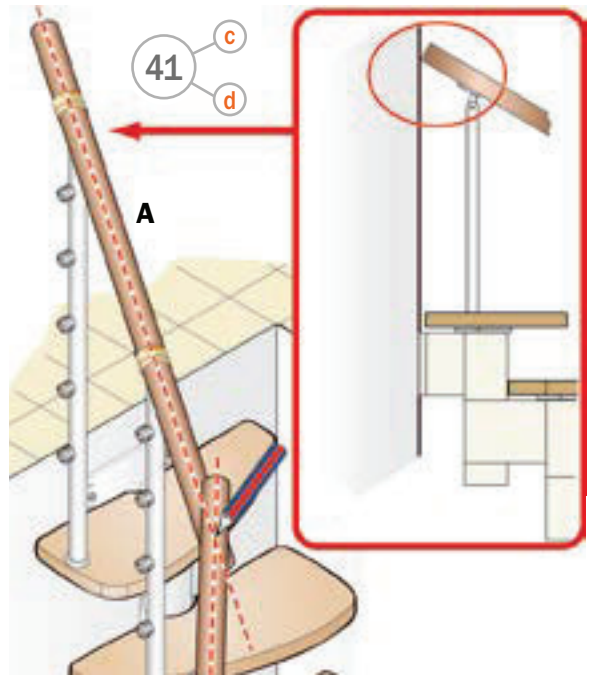
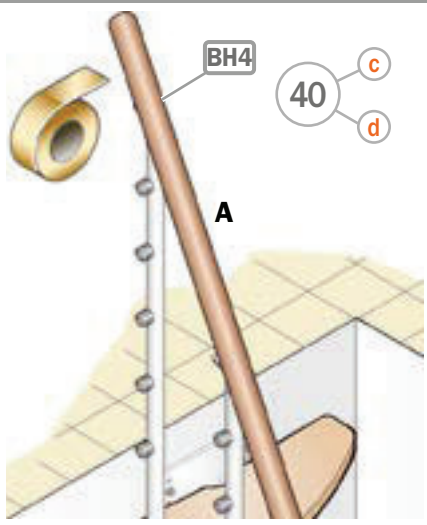
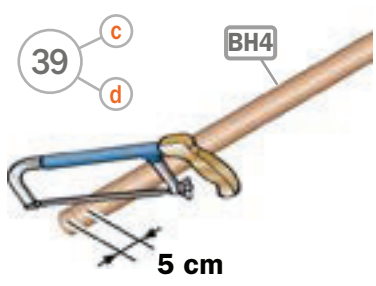

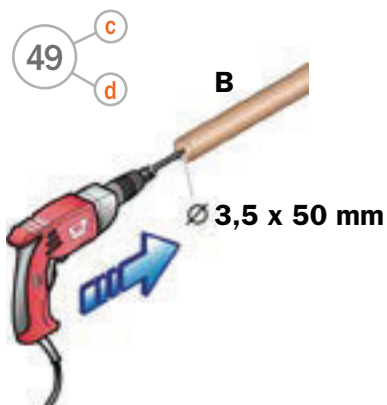
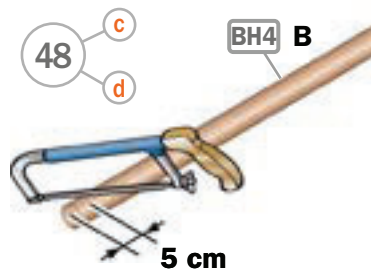
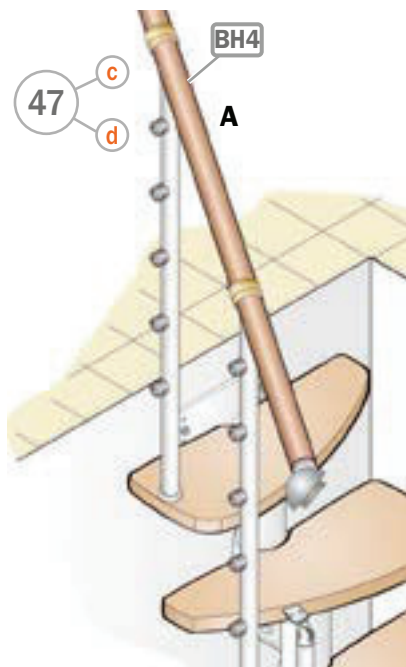
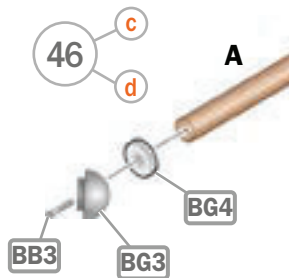

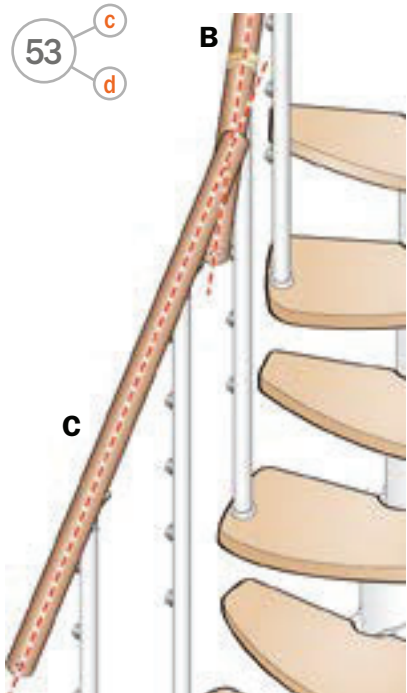
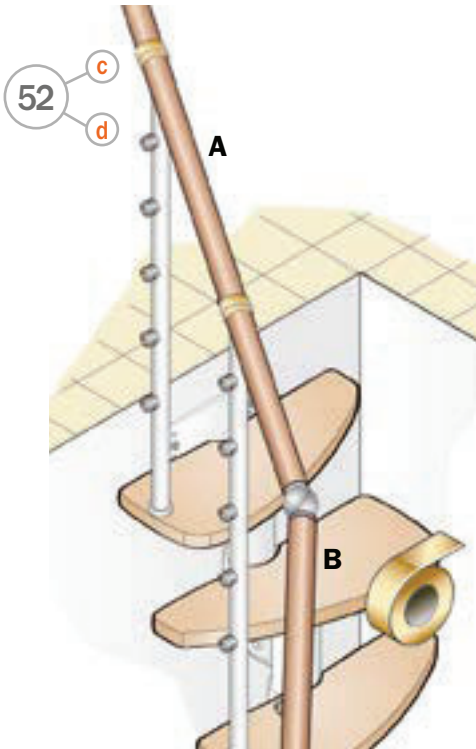
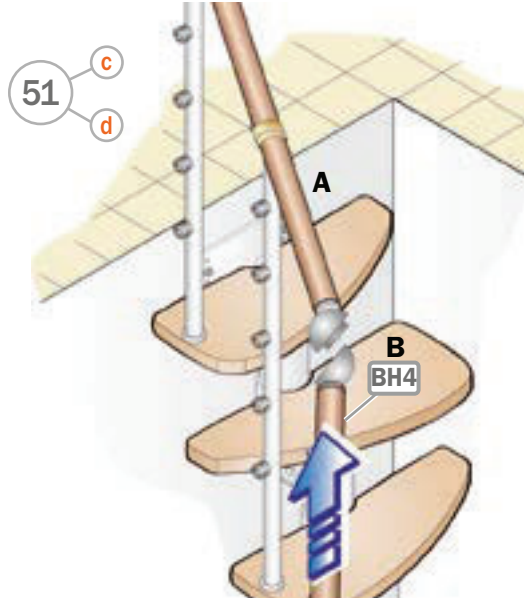
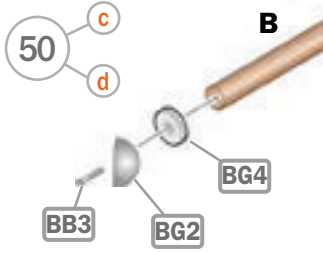

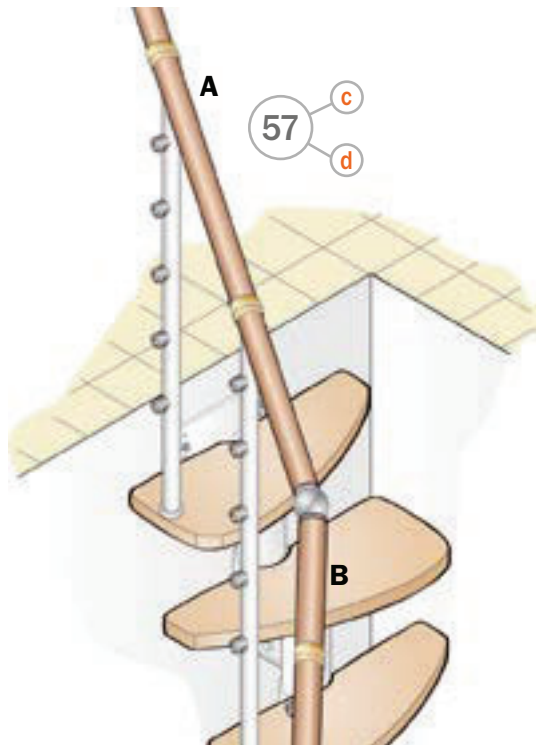
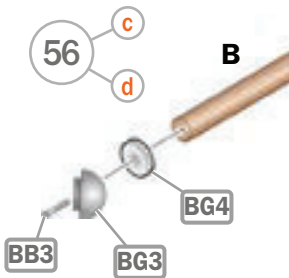
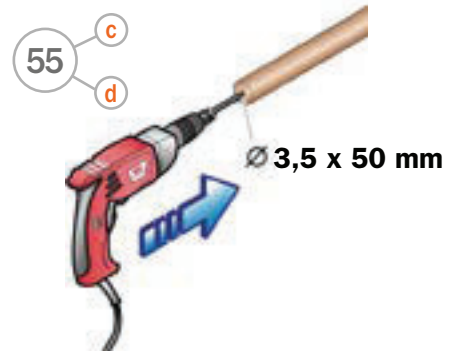
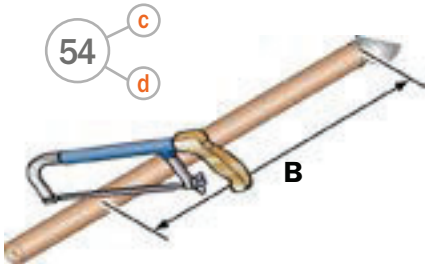

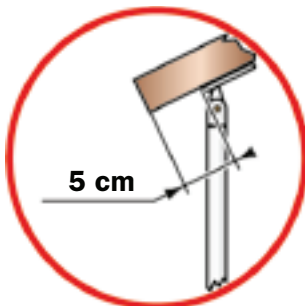
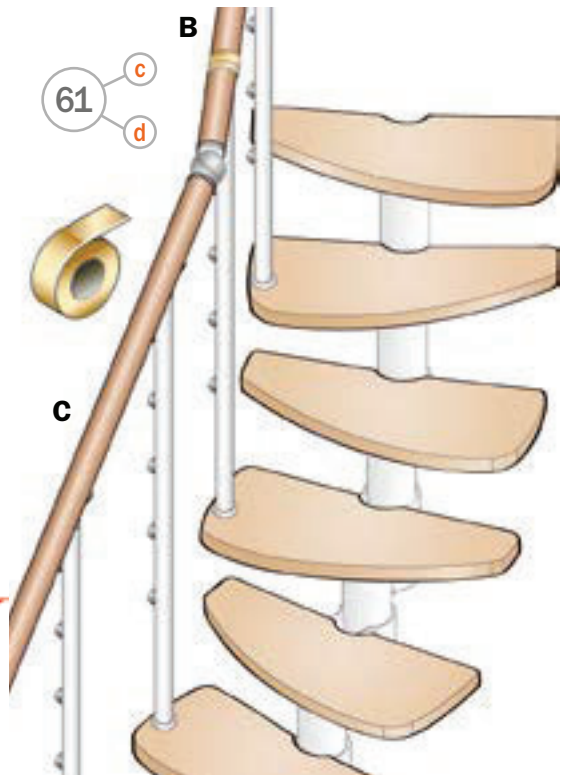
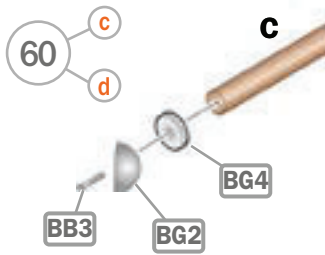
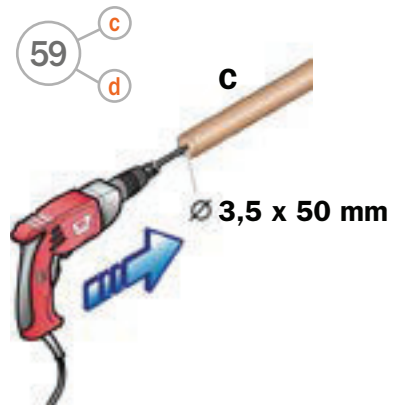
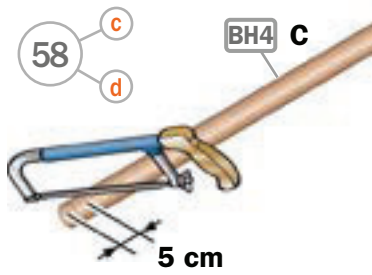

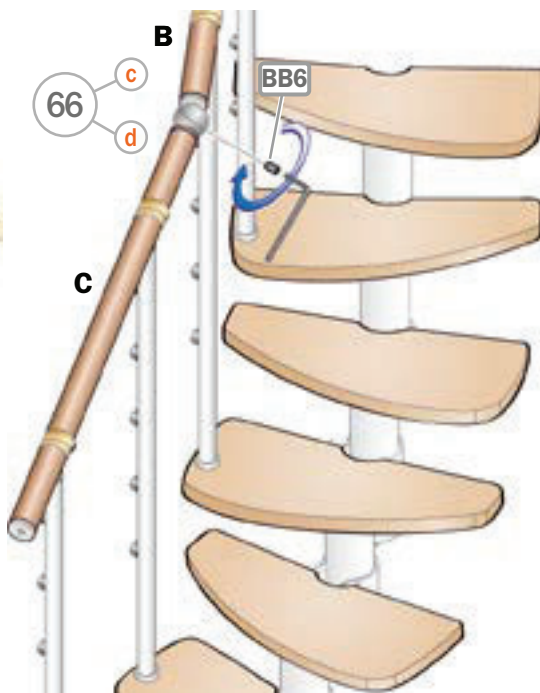
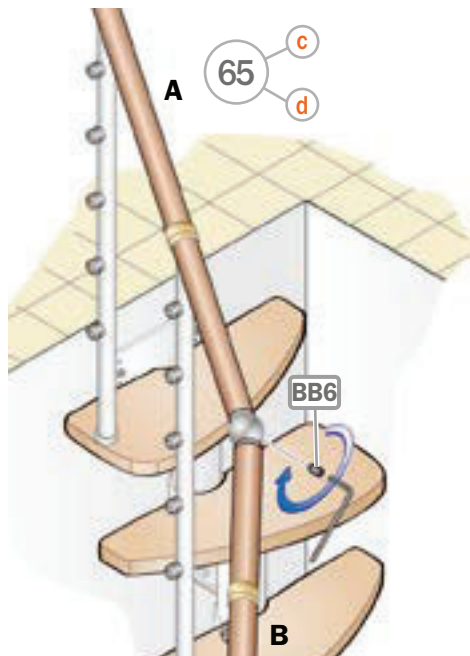
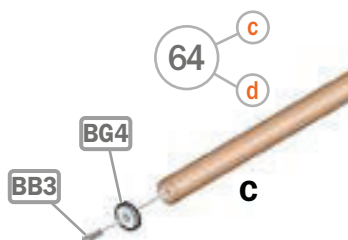
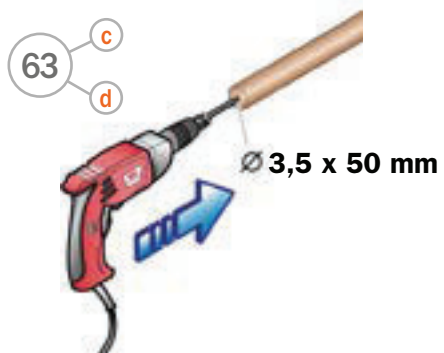
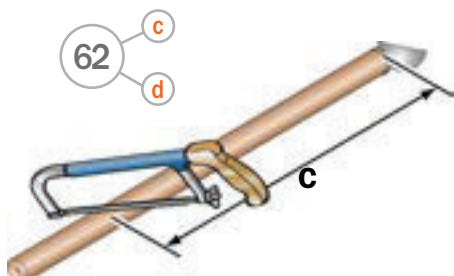

67
b
d

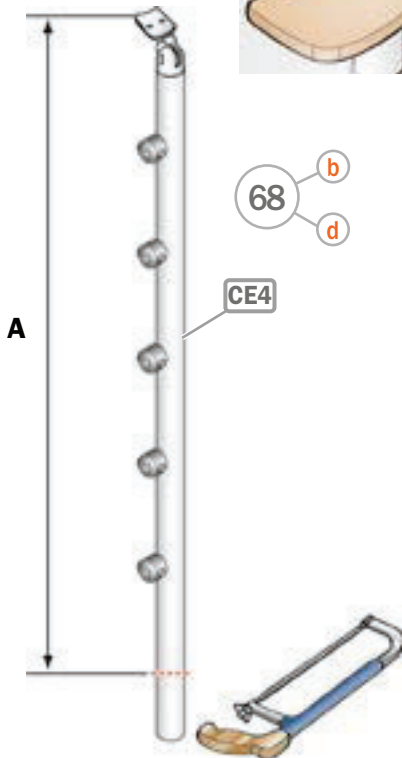
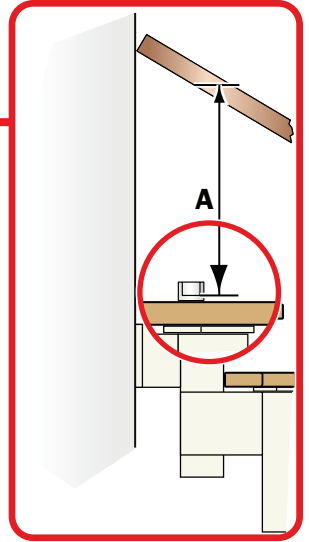
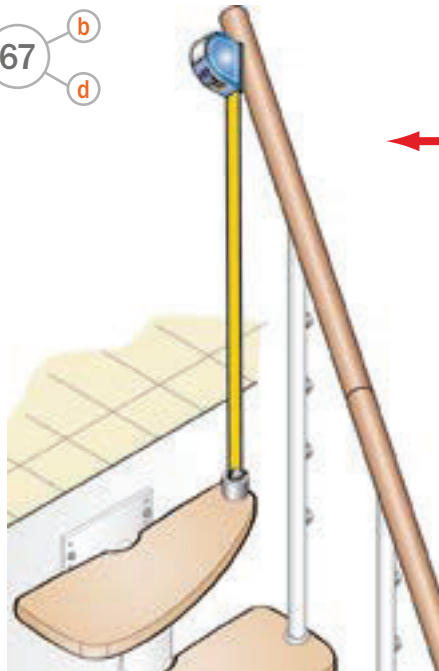

69
b
d

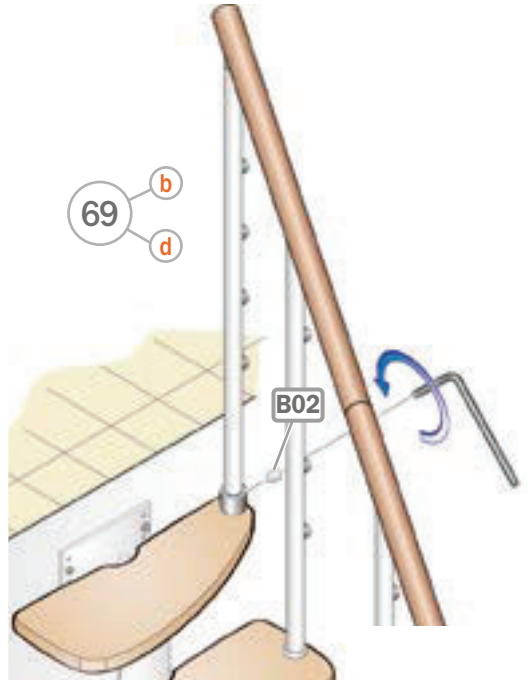

70

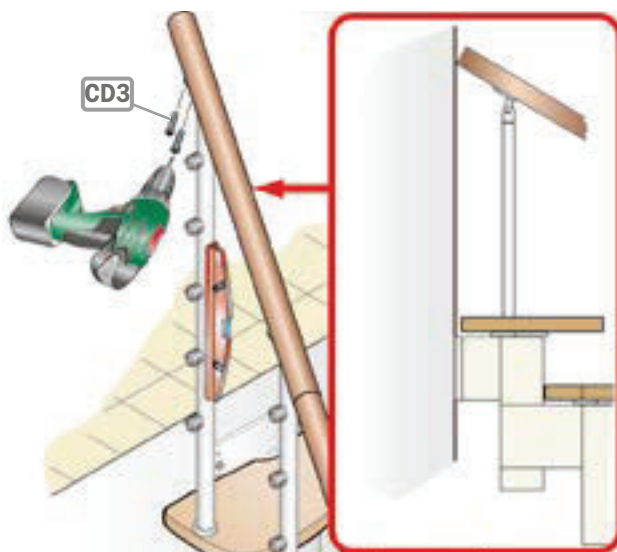

71

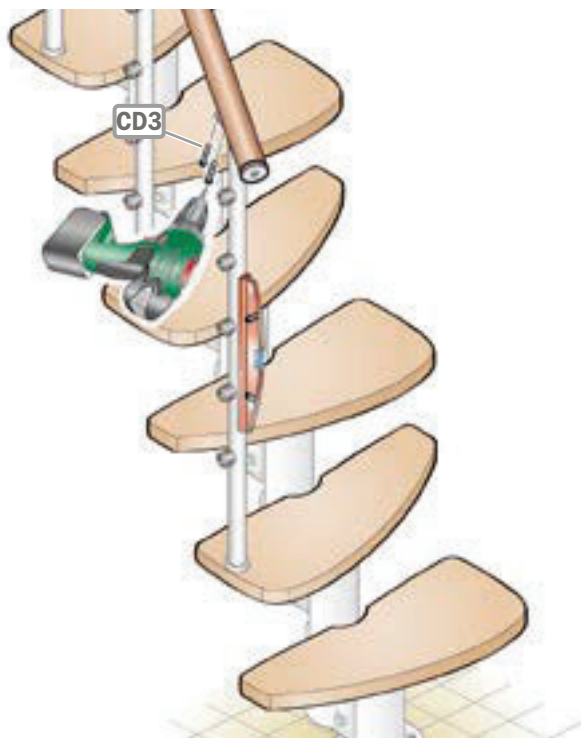

72

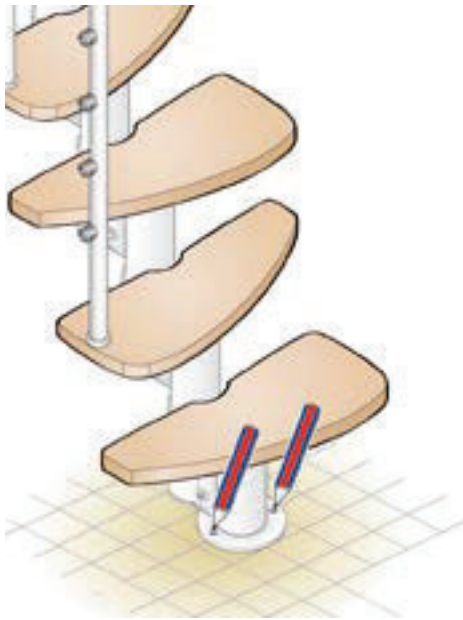

73 b

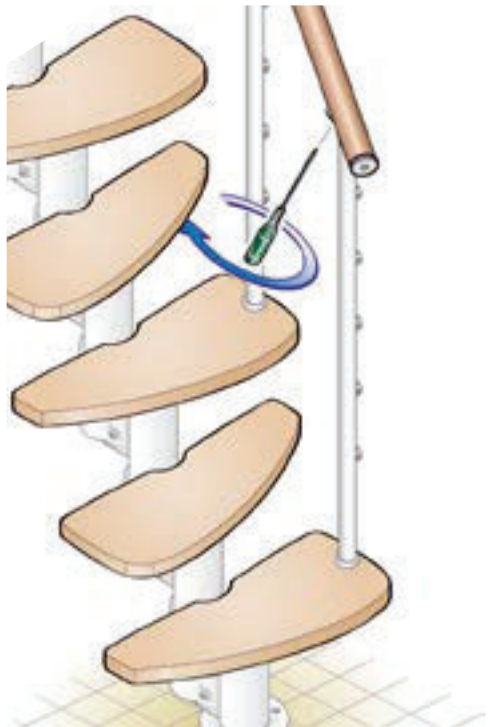

74 b

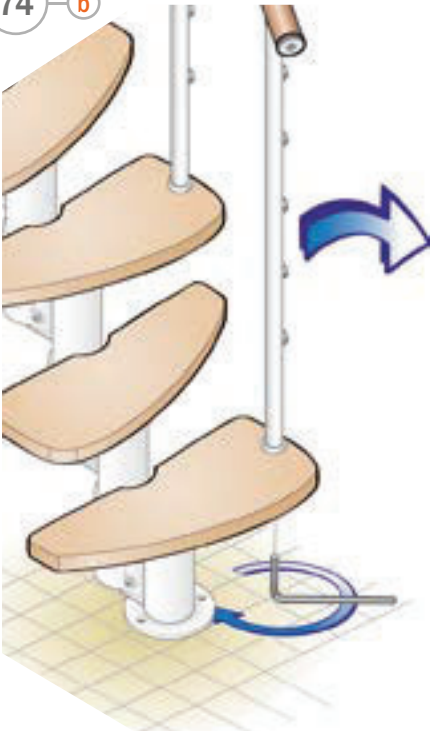

75

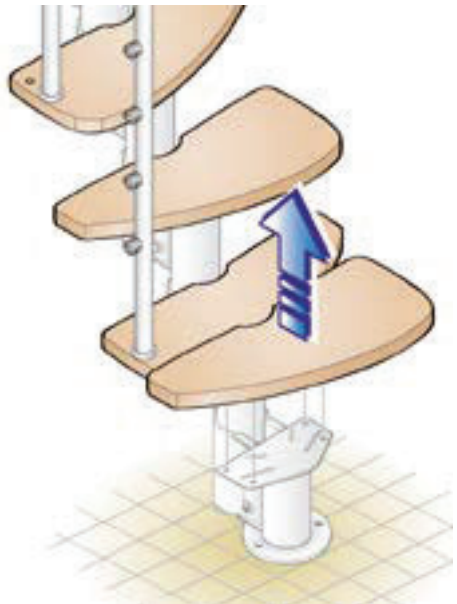

76

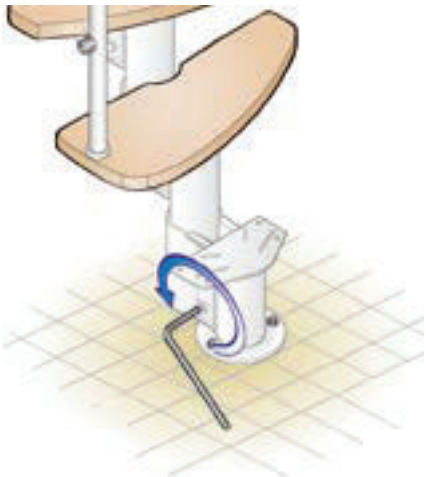

77



78

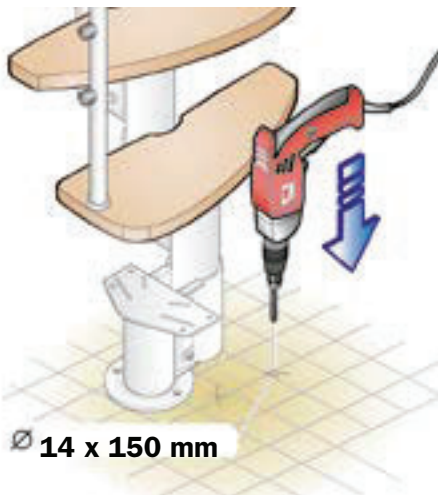

Ø 14 x 150 mm

79

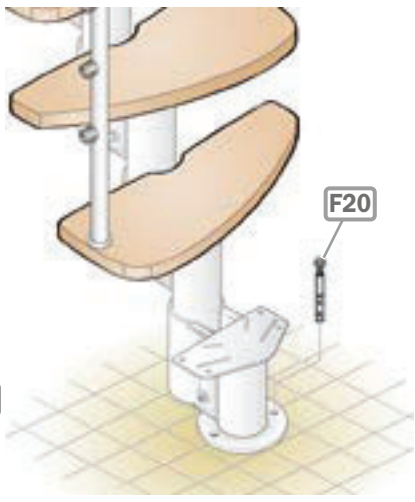

F20

F20



58

80

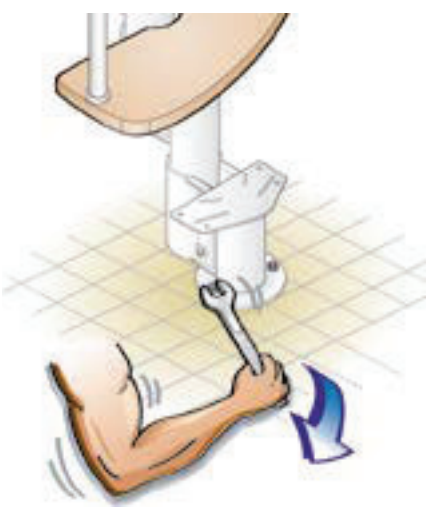

81

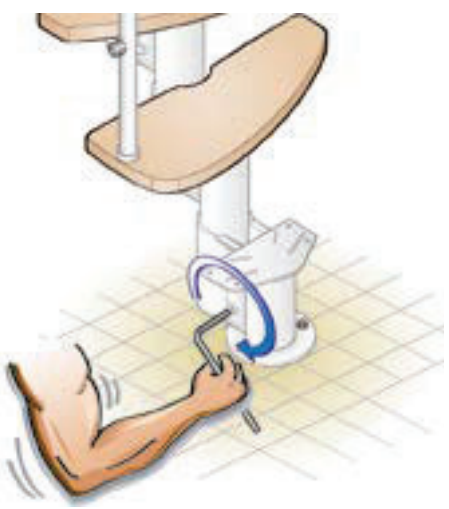

82

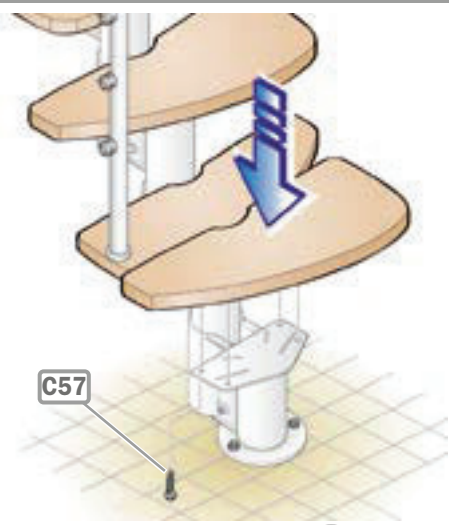

83 b

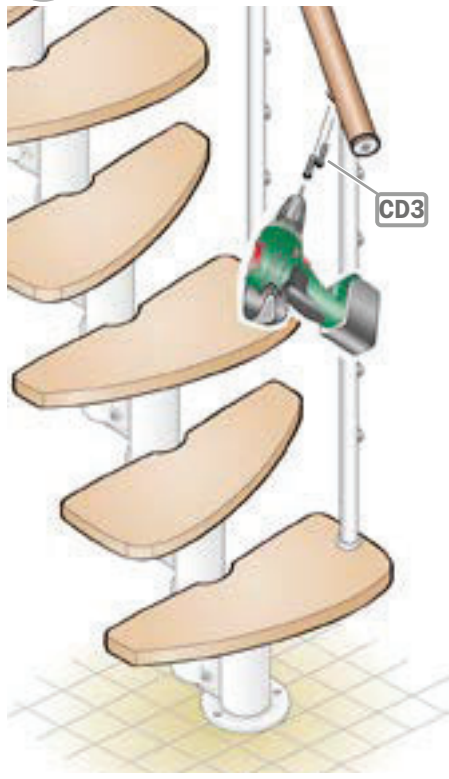

84 b

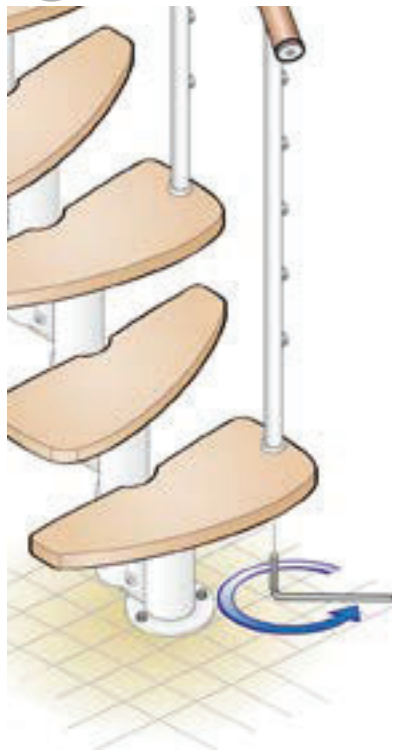

85

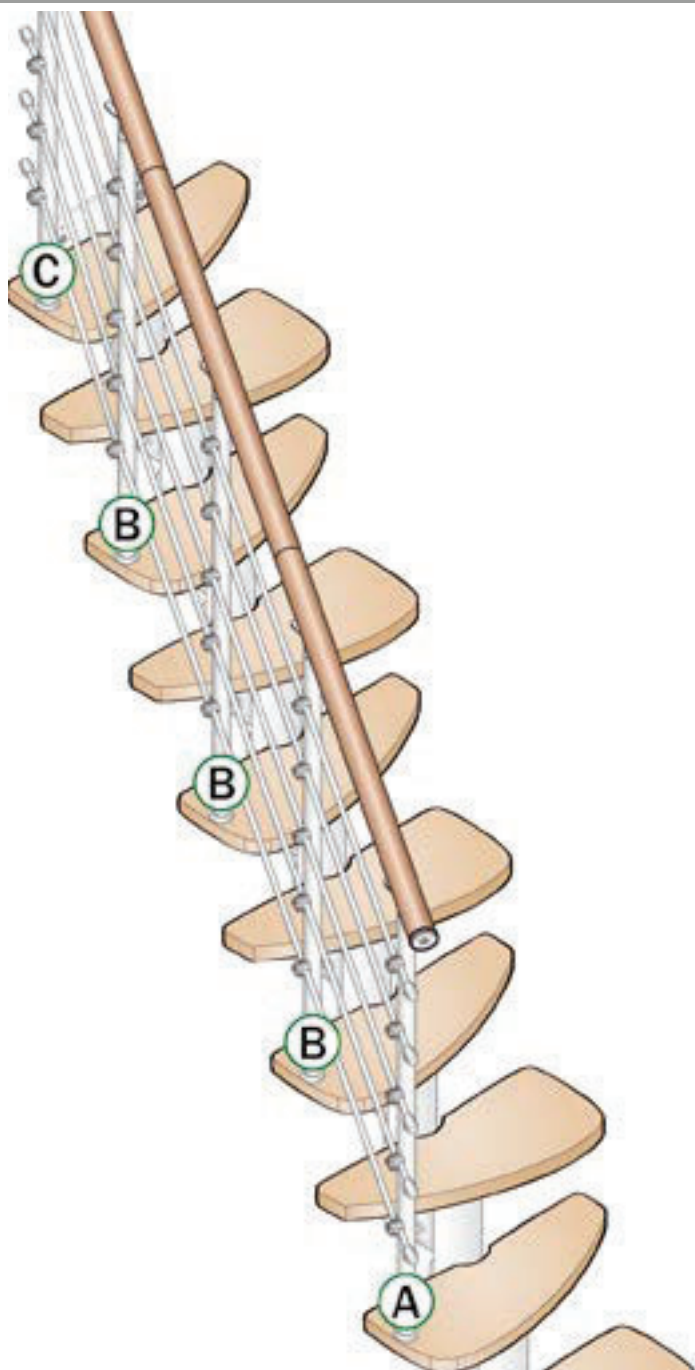

86

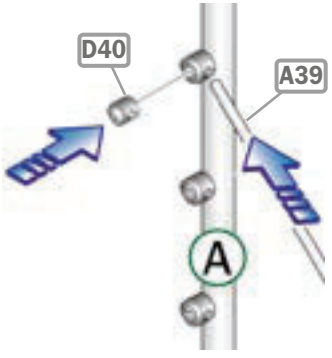

87



88

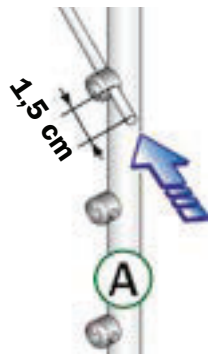

89

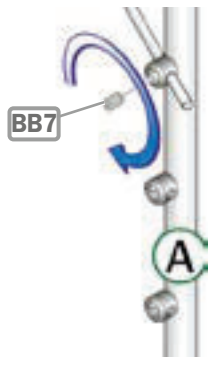

90

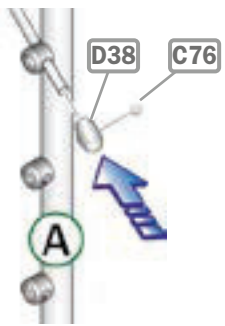

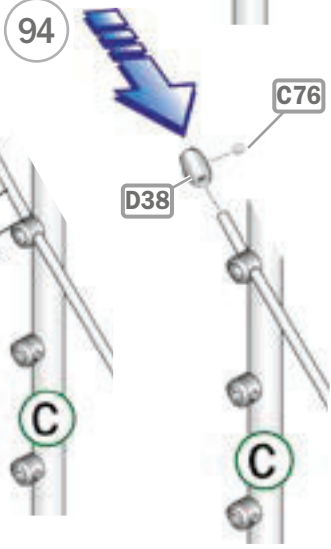
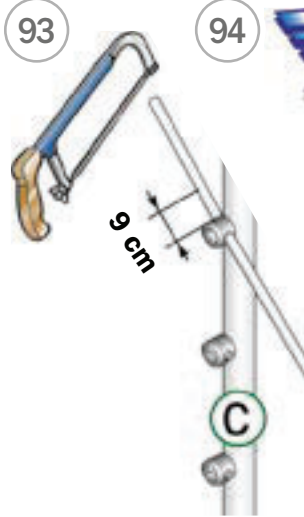
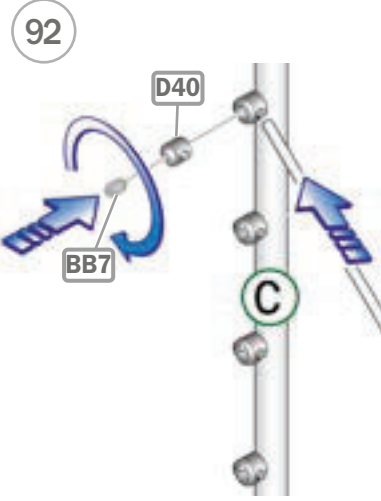
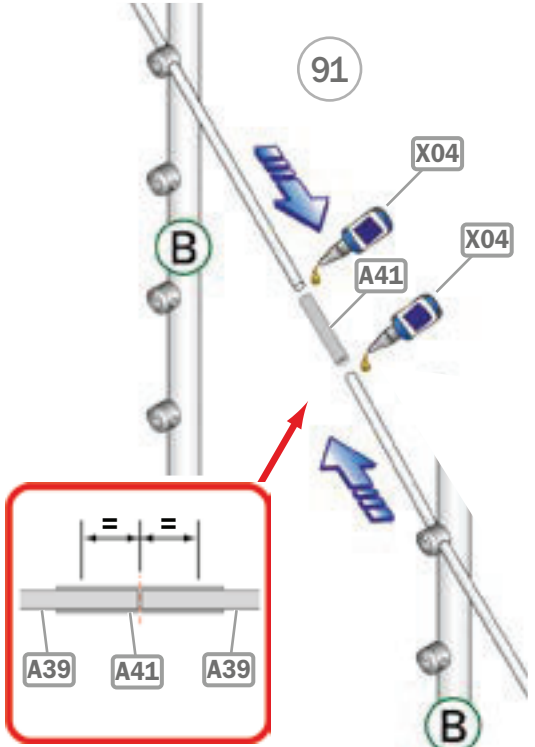
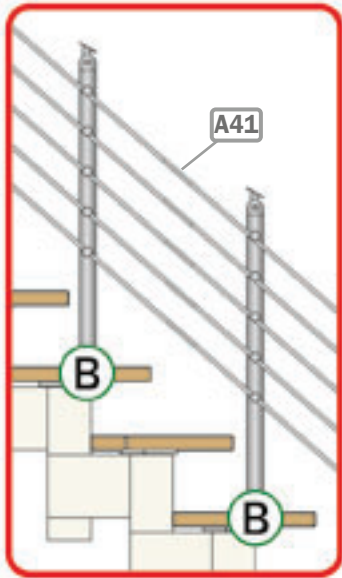

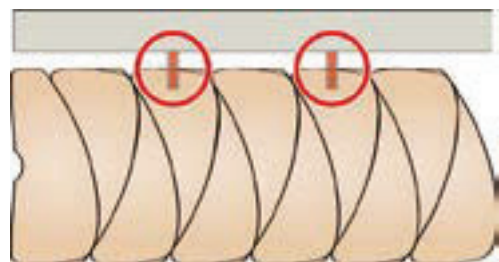
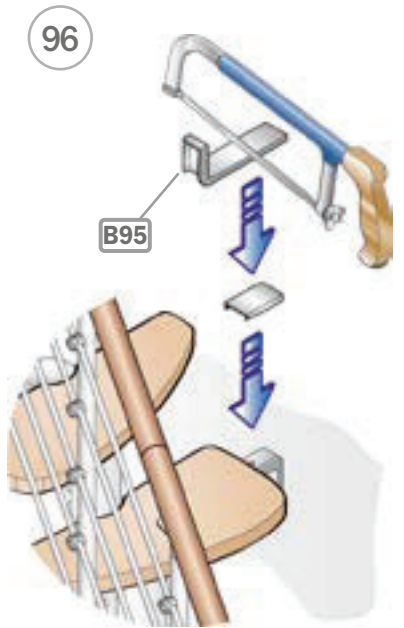
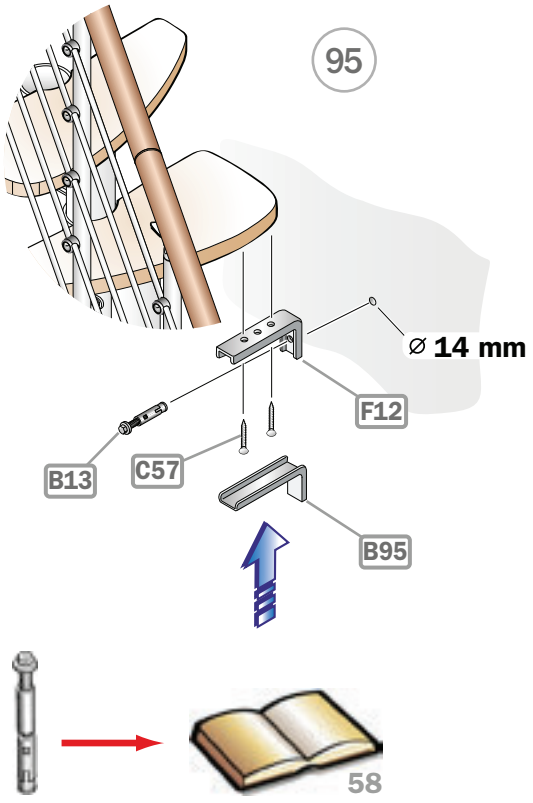

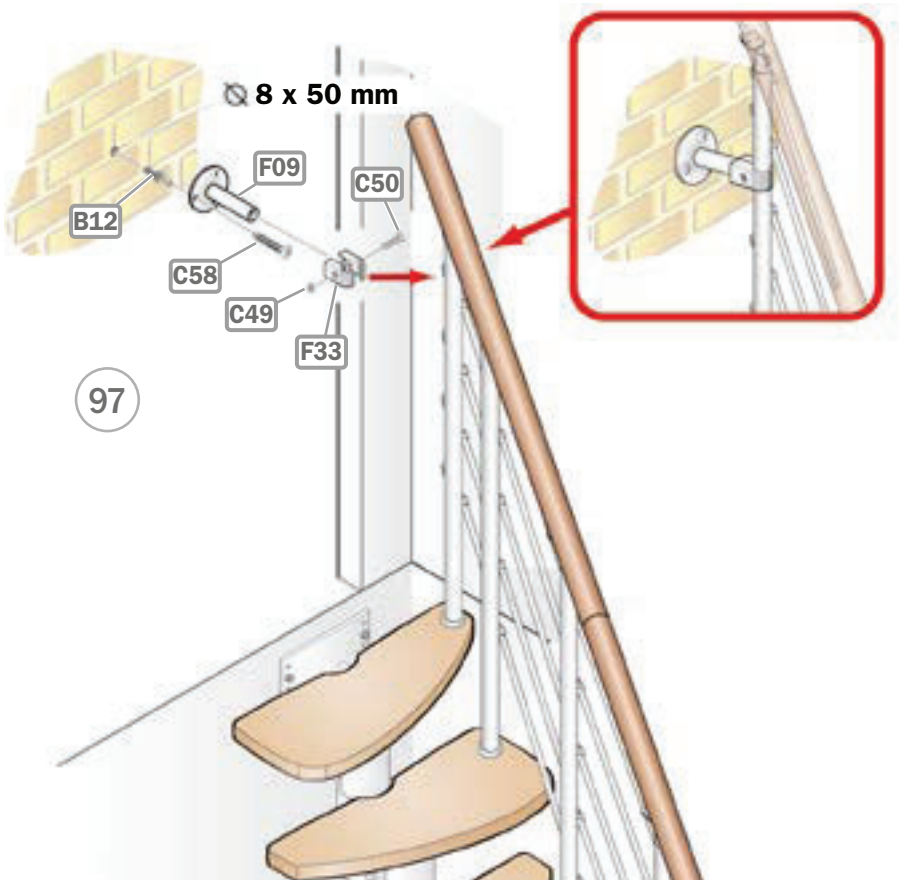

97

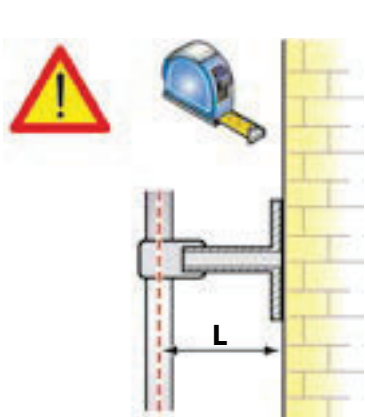

98

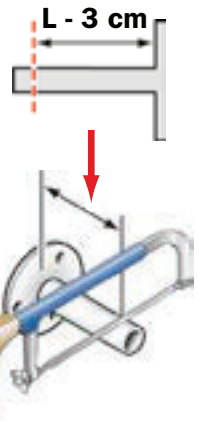

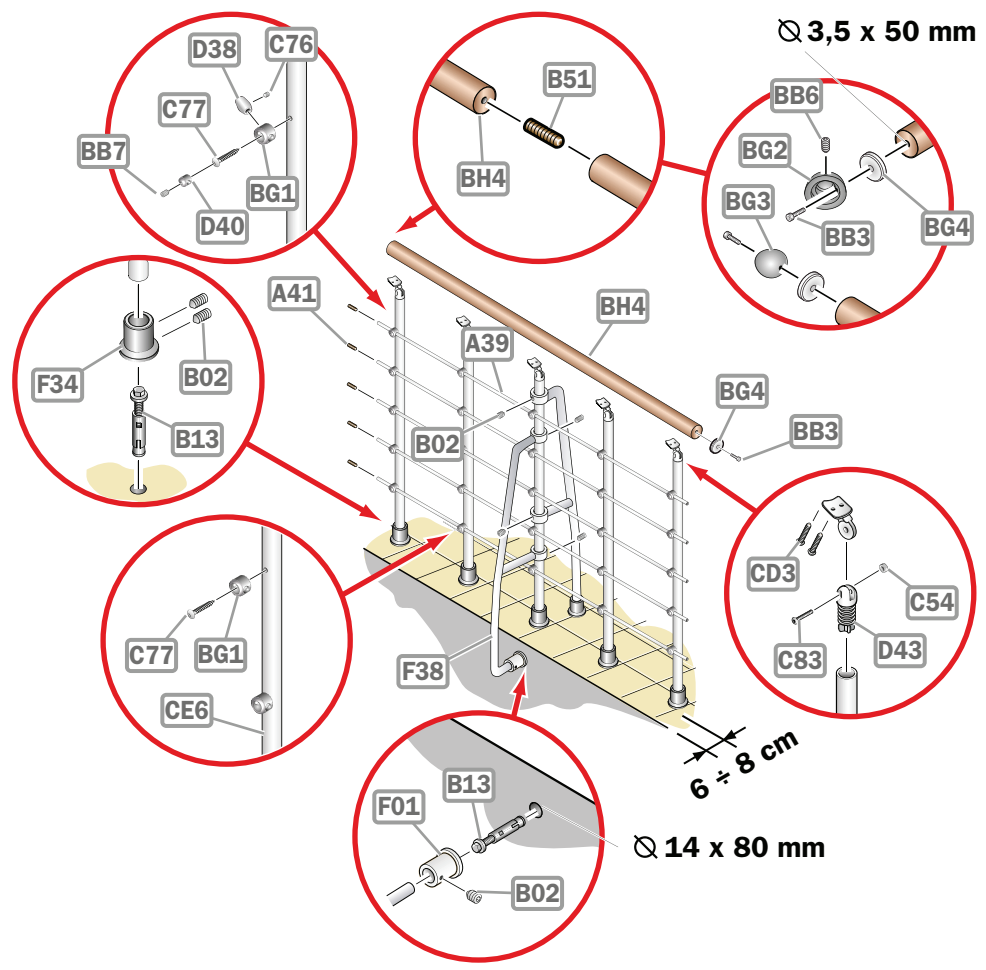
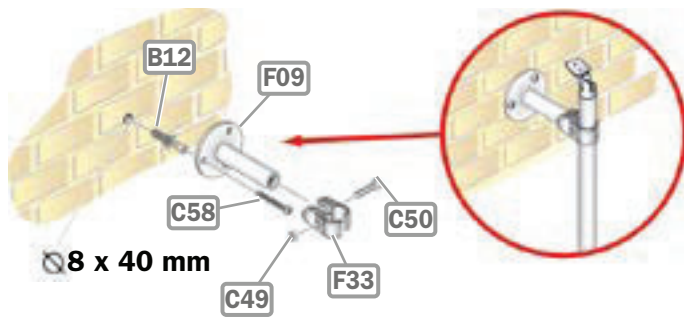

A39



5

A41



5

B02



13

B12



3

B13



6

B51



1

BB3



4

BB6



1

BB7



10

BG1



25

BG2

1



BG3

1

BG4



4

BH4



1

C49



1

C50



1

C54



5

C58



3

C76



10

C77



25

C83



5

CD3



10

CE6



5

D38



10

D40



10

D43



5

F01



1

F09



1

F33



2

F34



5

F38

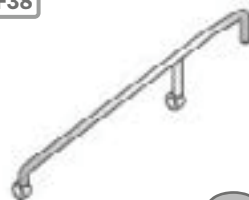

1

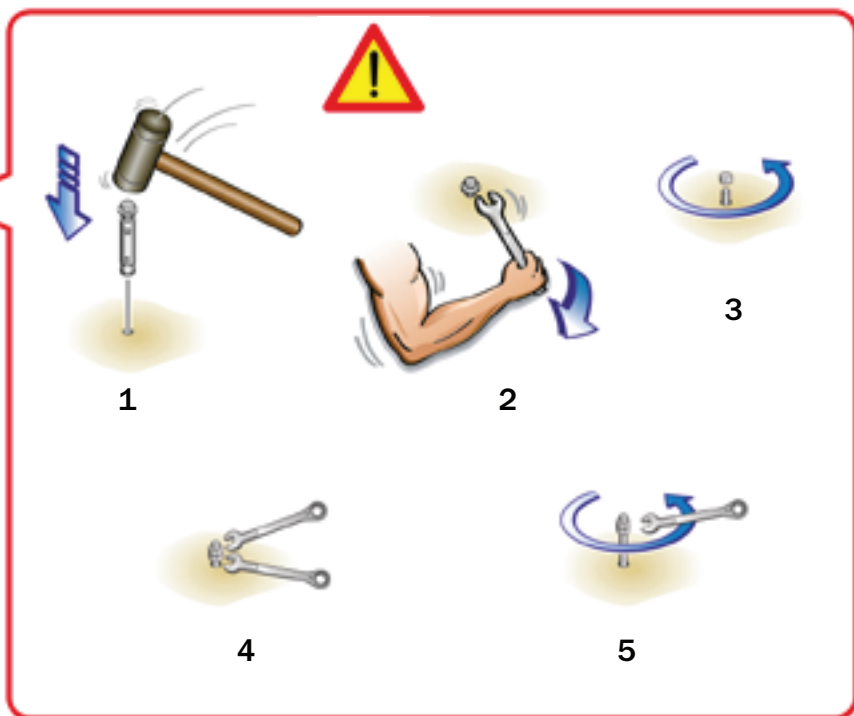
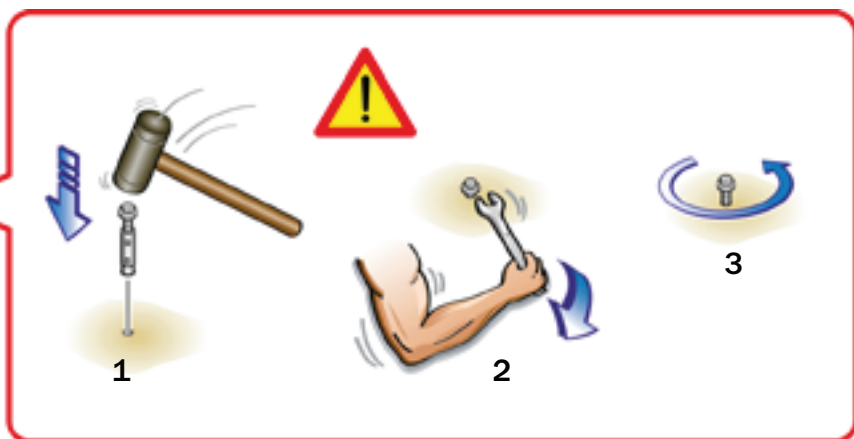



Italiano	DATI IDENTIFICATIVI DEL PRODOTTO
English	PRODUCT DETAILS
Deutsch	PRODUKTEIGENSCHAFTEN
Français	DONNÉES D'IDENTIFICATION DU PRODUIT
Español	DATOS DE IDENTIFICACIÓN DEL PRODUCTO
Svenska	PRODUKTDETALJER
Dansk	PRODUKTETS IDENTIFIKATIONSDATA
Norsk	PRODUKTINFORMASJON
Suomi	TUOTTEEN TUNNISTETIEDOT
Česky	IDENTIFIKAČNÍ ÚDAJE O VÝROBKU
Slovensky	IDENTIFIKAČNÉ ÚDAJE O VÝROBKU



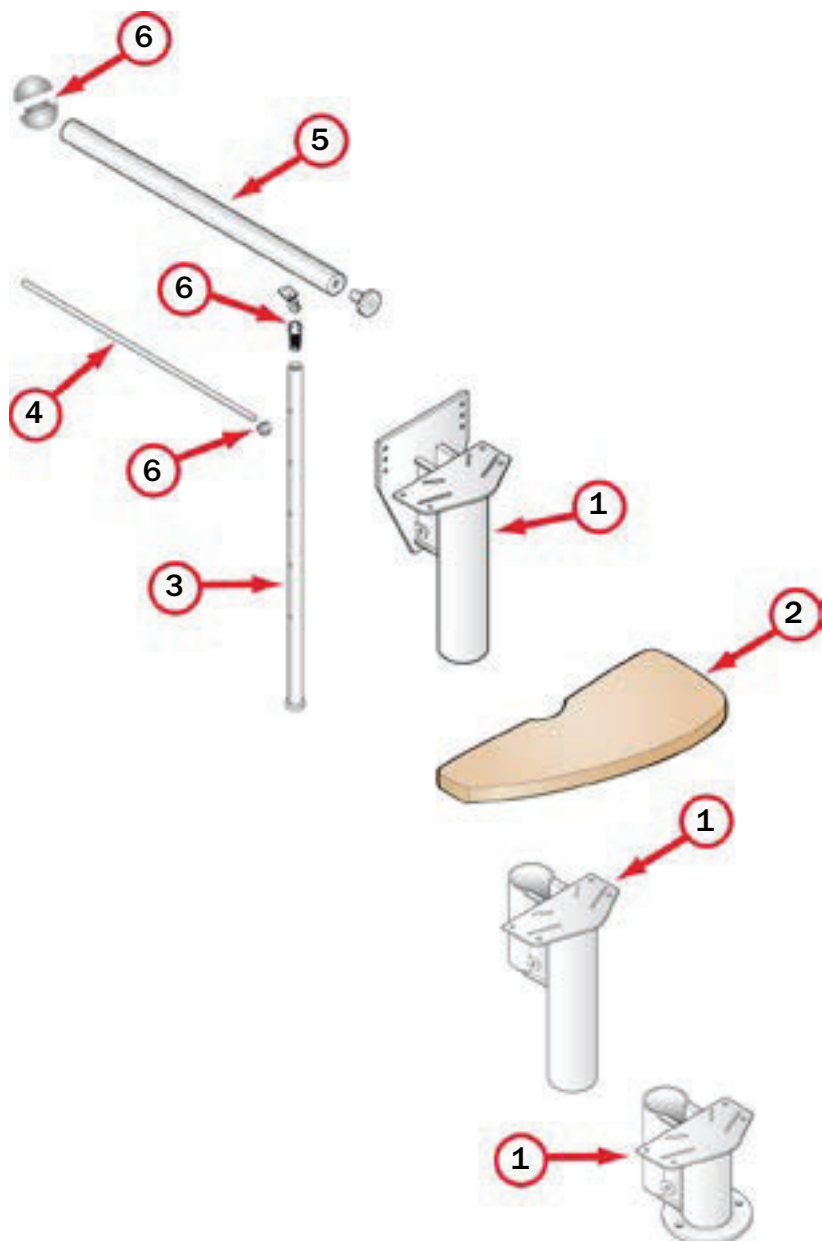

IT)

dati identificativi del prodotto

denominazione commerciale: **ZEN**

tipologia: scala a giorno con gradini sfalsati e rotazione delle rampe con pendenza

materiali impiegati

STRUTTURA

descrizione

composta da elementi **(1)** metallici assemblati fra di loro con bulloni

materiali

Fe 370

finitura

verniciatura a forno con polveri epossidiche

GRADINI

descrizione

gradini **(2)** legno sagomati assemblati alla struttura con bulloni

materiali

multistrato di betulla/faggio

finitura

tinta: all'acqua

fondo: all'acqua

finitura: all'acqua

RINGHIERA

descrizione

composta da colonnine **(3)** verticali in metallo fissate ai gradini **(2)**, da 5 tondini longitudinali **(4)** e da corrimano **(5)** in legno

materiali

colonnine **(3)**: Fe 270

tondini **(4)**: acciaio inox

fissaggi **(6)**: nylon

corrimano **(5)**: faggio

finitura

colonnine **(3)**: verniciatura a forno con polveri epossidiche

corrimano **(5)**: tinta: all'acqua

fondo: acrilica

finitura: acrilica

PULIZIA E MANUTENZIONE OBBLIGATORIA

Eseguire la pulizia della scala alla prima comparsa di macchie di sporco e depositi di polvere e periodicamente almeno ogni 6 mesi con panno morbido inumidito in acqua e detergenti specifici non abrasivi ed aggressivi. NON usare mai pagliette abrasive o in ferro. Pulire ed asciugare accuratamente dopo il lavaggio con un panno in microfibra al fine di eliminare gli aloni del calcare presente nell'acqua. Dopo circa 12 mesi dalla data di installazione, controllare il serraggio della viteria dei vari componenti. Al verificarsi di qualsiasi minimo malfunzionamento è obbligatorio effettuare una manutenzione straordinaria, da eseguire subito e a regola d'arte.

PRECAUZIONI D'USO

Evitare usi impropri e non consoni al prodotto, eventuali manomissioni o installazioni non rispondenti alle istruzioni del produttore possono inficiare le conformità prestabilite del prodotto.

EN)

product details

trade name: **ZEN**

type: flight staircase with alternate treads and flight rotation with slope

materials used

STRUCTURE

description

composed of metallic elements **(1)** assembled between themselves by bolts

materials

Fe 370

finishing

oven varnishing with epoxy powders

TREADS

description

wooden shaped treads **(2)** assembled to the structure by bolts

materials

birch plywood/beech

finishing

colour: water-base

undercoat: water-base

finishing: water-base

RAILING

description

composed of metal vertical balusters **(3)** fixed to the treads **(2)**, of 5 parallel steel bars **(4)** and of a wooden handrail **(5)**

materials

balusters **(3)**: Fe 370

bars **(4)**: stainless steel

fixings **(6)**: nylon

handrail **(5)**: beech

finishing

balusters **(3)**: oven varnishing with epoxy powders

handrail **(5)**: colour: water-base

undercoat: acrylic

finishing: acrylic

OBLIGATORY CLEANING AND MAINTENANCE

Clean the treads as soon as dirt spots and dust deposits appear and at least every 6 months using a soft cloth moistened with water and specific nonabrasive and non-aggressive detergents. NEVER use abrasive scourers. After cleaning, thoroughly dry the surfaces with a microfibre cloth to remove the haloes that form because of the limestone in the water. Approximately 12 months from the date of installation, check tightness of the screws of the various components. Should even the smallest malfunction occur, it is obligatory to immediately and professionally carry out extraordinary maintenance.

USE PRECAUTION

Avoid any improper use that is not in accordance with the product. Possible violations or installations which don't comply with the providers instructions can invalidate the agreed product conformities.

DE)

Produkteigenschaften

kommerzielle Bezeichnung: **ZEN**

Typologie: Mittelholztreppe mit versetzten Stufen, Wendelung der Treppenhäufe mit Neigung

verwendete Materialien

STRUKTUR

Beschreibung

bestehend aus Metallteilen (1) die miteinander durch Bolzen verbunden sind

Materialien

Fe 370

Ausführung

Ofenlackierung mit Epoxydharzpulver

STUFEN

Beschreibung

geformte Stufen (2) aus Holz an der Struktur mittels Bolzen befestigt

Materialien

Mehrschichtbirkenholz/Buche

Ausführung

Beizung: Wasserfarbe
Wasserfarbe-Grundierung
Wasserfarbe-Oberlack

GELÄNDER

Beschreibung

bestehend aus senkrechten Metallgeländerstäben (3) die auf den Stufen (2) befestigt sind, 5 Längsstäben (4) und einem Holzhandlauf (5)

Materialien

Geländerstäben (3): Fe 370

Längsstäben (4): Edelstahl

Befestigungen (6): Nylon

Handlauf (5): Buche

Ausführung

Geländerstäben (3): Ofenlackierung mit Epoxydharzpulver
Handlauf (5): Beizung: Wasserfarbe
Wasserfarbe-Grundierung
Wasserfarbe-Oberlack

REINIGUNG UND VORGESCHRIEBENE INSTANDHALTUNG

Die Treppe sofort reinigen wenn Schmutzfl ecken und Staubansammlungen entstehen und sie mindestens alle 6 Monate mit einem weichen, mit Wasser und einem spezifischen, weder scheuernden, noch aggressiven Reinigungsmittel befeuchteten Lappen abzuwischen. NIEMALS scheuernde Eisenschwämme verwenden. Nach der Feuchtreinigung mit einem Mikrofasertuch sorgfältig nachtrocknen, um die Schlierenbildung durch kalkhaltiges Wasser zu vermeiden. 12 Monate nach der Montage das Anzugsmoment der Schrauben der verschiedenen Komponenten kontrollieren. Bei Auftreten einer noch so geringen Funktionsstörung muss unbedingt sofort eine fachgerechte außerordentliche Instandhaltung durchgeführt werden.

VORSICHTSMAßNAHMEN FÜR DIE ANWENDUNG

Die falsche und unangemessene Verwendung des Produkts vermeiden. Eventuelle Beschädigungen oder nicht der Montageanleitung des Herstellers gemäße Einrichtungen können die vorgegebene Produktkonformität für ungültig erklären.

FR)

données d'identification du produit

denomination commerciale : **ZEN**

typologie : escalier à volée avec marches decalées et rotation des volées en pente

matériaux utilisés

STRUCTURE

description

composée d'éléments (1) métalliques assemblés entre eux par boulonnage

matériaux

Fe 370

finition

vernissage à chaud avec poudres époxy

MARCHES

description

marches façonnées (2) en bois assemblées à la structure par boulonnage

matériaux

multipli de bouleau/hêtre

finition

vernis : à l'eau
mordant : à l'eau
 finition : à l'eau

GARDE-CORPS

description

composé de colonnettes (3) verticales en métal fixées aux marches (2), de 5 lisses longitudinaux (4) et d'une main courante (5) en bois

matériaux

colonnettes (3) : Fe 370

lisses (4) : acier inoxydable

fixations (6) : nylon

main courante (5) : hêtre

finition

colonnettes (3) : vernissage à chaud avec poudres époxy
main courante (5) : vernis : à l'eau
mordant : à l'eau
 finition : à l'eau

NETTOYAGE ET MAINTENANCE OBLIGATOIRE

Nettoyer les marches dès que des taches de saleté ou des dépôts de poussière apparaissent ; effectuer également un nettoyage périodique, tous les 6 mois, à l'aide d'un chiffon doux, humecté d'eau et de détergents spécifiques non abrasifs et non agressifs. NE JAMAIS utiliser de la paille de fer abrasive. Après lavage, nettoyer et essuyer soigneusement avec un chiffon en microfibre, afin d'éliminer les auréoles provoquées par le calcaire contenu dans l'eau. Environ 12 mois après la date d'installation, contrôler le serrage des vis des différents composants. À la moindre défaillance, il est obligatoire d'effectuer immédiatement une maintenance corrective, dans les règles de l'art.

PRECAUTION D'UTILISATION

Eviter l'utilisation impropre et non conforme au produit. D'éventuelles alterations ou installations non correspondantes aux instructions du producteur peuvent invalider les conformités préétablies du produit.

ES)

datos de identificación del producto

denominación comercial: **ZEN**

tipo: escalera abierta con peldaños de paso alternado y rotación de los tramos con pendiente

materiales empleados

ESTRUCTURA

descripción

compuesta por elementos (1) metálicos ensamblados entre ellos mediante pernos

materiales

Fe 370

acabado

barnizado en horno con polvos epoxídicos

PELDAÑOS

descripción

peldaños (2) de madera perfilados y ensamblados a la estructura mediante pernos

materiales

multicapa de abedul/haya

acabado

barniz: al agua

imprimación: al agua

acabado: al agua

BARANDILLA

descripción

compuesta por barrotes (3) verticales de metal fijados a los peldaños (2), por 5 barras longitudinales (4) y por un pasamanos (5) de madera

materiales

barrotes (3): Fe 370

barras (4): acero inoxidable

fijaciones (6): nylon

pasamanos (5): haya

acabado

barrotes (3): barnizado en horno con polvos epoxídicos

corrimano (5): barniz: al agua

imprimación: al agua

acabado: al agua

LIMPIEZA Y MANTENIMIENTO OBLIGATORIO

Realizar la limpieza de la escalera en cuanto aparezcan manchas de suciedad y depósitos de polvo, y periódicamente al menos cada 6 meses, con un paño suave humedecido en agua y detergentes específicos no abrasivos ni agresivos. NO utilizar nunca lanas abrasivas o de hierro. Limpiar y secar bien después del lavado utilizando un paño de microfibra para eliminar las aureolas de cal dejadas por el agua. Transcurridos unos 12 meses desde la fecha de instalación, comprobar que los tornillos que fijan las distintas partes sigan bien apretados. Ante el menor defecto de funcionamiento, es obligatorio realizar un mantenimiento extraordinario según las reglas del arte.

PRECAUCIONES DE USO

Evitar usos impropios y no conformes con el producto. Eventuales manipulaciones o instalaciones que no cumplan con las instrucciones del fabricante pueden menoscabar las cualidades certificadas en las pruebas de conformidad a las que previamente fue sometido el producto.

SV)

produkt detaljer

kommersiell benämning: **ZEN**

typ: öppen trappa med avfalsade trappsteg och av rotationstyp för trappstegsråd med lutning

konstruktionsmaterial

STRUKTUR

beskrivning

består av metallelement (1) som sitter ihop med varandra med bultar

material

Fe 370

ytbehandling

ugnslackerade med epoxipulver

TRAPPSTEG

beskrivning

trappsteg (2) av profilsågat trä monterade på stammen med bultar

material

björkplywood/bok

ytbehandling

färg: vattenbaserad

botten: vattenbaserad

ytbehandling: vattenbaserad

RÄCKE

beskrivning

bestående av vertikala stolpar (3) av metall som sitter fast på trappstegen (2) kablarna av 5 rostfritt stål (4) och en handledare (5) av trä

material

stolpar (3): Fe 370

kablarna (4): rostfritt stål

fästansordningar (6): nylon

handledare (5): bokträ

ytbehandling

stolpar (3): ugnslackerade med epoxipulver

handledare (5): färg: vattenbaserad

botten: vattenbaserad

ytbehandling: vattenbaserad

NÖDVÄNDIG RENGÖRING OCH UNDERHÅLL

Rengör trappan vid första smutsfläck eller när damm samlas, och regelbundet minst var 6:e månad. Rengör med en trasa fuktad med vatten och lämpligt rengöringsmedel som inte är slipande eller frätande. Använd aldrig slipande svampar eller stålull. Rengör och torka noggrant efter rengöring med en mikrofiberduk för att undvika kalkfläckar från vattnet. Kontrollera åtdragningen av skruvarna för de olika komponenterna efter 12 månader. Vid varje typ av felfunktion är det obligatoriskt att utföra ett extra underhåll. Detta ska utföras omedelbart och på ett yrkesmannamässigt sätt.

ANVÄNDNINGSFÖRESKRIFTER

Undvik att använda produkten på ett olämpligt sätt. Eventuell mixtring eller installation som inte överensstämmer med tillverkarens anvisningar kan leda till att överensstämmelsekraven som har fastställts för produkten inte längre gäller.

DA) produktets identifikasjonsdata

handelsbetegnelse: **ZEN**

type: svingtrappe med forskudte trin og trappeløbsrotasjon med hældning

brugte materialer

STRUKTUREN

beskrivelse

strukturen består af metalelementer **(1)** som er sammensatte med bolte

materialer

Fe 370

finish

malet i ovn med epoxypulver

TRIN

beskrivelse

trin **(2)** i massivt profileret bølgetræ sammensat til strukturen med bolte

materialer

flerlags birk/bølgetræ

finish

vandmalet

grundet vandmalet

finish vandmalet

GELÆNDER

beskrivelse

bestående af vertikale balustre **(3)** i metal fastgjort til trinene **(2)**, af 5 langsgående rundjern **(4)** og en håndliste **(5)** i træ

materialer

balustre **(3)**: Fe 370

rundjern **(4)**: rustfri stål

fastgøringer **(6)**: nylon

håndliste **(5)**: bølgetræ

finish

balustre **(3)**: fornikling og gennemsigtig beskyttelseslakering

håndliste **(5)**: vandmalet

grundet vandmalet

finish vandmalet

RENGØRING OG PÅBUDET VEDLIGEHOLDELSE

Trappen skal rengøres når de første tegn på tilsmudsning og af støvaflejringer fremkommer, og i hvert fald regelmæssigt for hver 6. måned med en blød klud vædet i vand og specifikke ikke ætsende eller aggressive rengøringsmidler. Der må ALDRIG bruges skure- eller stålsvampe. Rengør og tør omhyggeligt med en mikrofiberklud efter vask for at fjerne kalkaflejringerne, der findes i vandet. Efter ca. 12 måneder fra installationsdatoen, kontrolleres fikseringen på de forskellige komponenters skruer. I tilfælde af en hvilken som helst fejlfunktion, er det påbudt at udføre en ekstraordinær vedligeholdelse, der bør udføres omgående og i overensstemmelse med bedste praksis.

FORHOLDSREGLER VED BRUG

Undgå ukorrekt brug, som produktet ikke er beregnet til. Eventuelle ændringer eller installationer, som ikke stemmer overens med producentens anvisninger, kan påvirke produktets overensstemmelse som fastsat inden brug.

NO) produktinformasjon

produktnavn: **ZEN**

karakteristikk: åpen trapp med trinn som er plassert vekselvis, og roterende trappeløp med stigning

produksjonsmaterialer

STRUKTUR

beskrivelse

sammensatt av metalelementer **(1)** festet sammen med bolter

materialer

Fe 370

finish

ovnslakkert med epoksyulver

TRAPPETRINN

beskrivelse

formede trappetrinn **(2)** i tre, montert og boltet fast på strukturen

materialer

kryssfinér i bjørk/bøk

finish

fargestoff: vannbasert

underlagsstrøk: vannbasert

finish: vannbasert

REKKVERK

beskrivelse

sammensatt av lodrette spiler i metall **(3)**, festet i trappetrinnene **(2)**, av 5 langsgående stenger **(4)** og en håndløper **(5)** i tre

materialer

spiler **(3)**: Fe 370

stengene **(4)**: rustfritt stål

fester **(6)**: nylon

håndløper **(5)**: bøk

finish

spiler **(3)**: ovnslakkert med epoksyulver

håndløper **(5)**: fargestoff: vannbasert

underlagsstrøk: vannbasert

finish: vannbasert

RENGØRING OG NØVDENDIG VEDLIKEHOLD

Rengjør trappen straks det oppstår flekker eller støvansamlinger. Trappen må dessuten rengjøres jevnlig minst hver 6. måned med en myk klut fuktet med vann og spesielle milde rengjøringsmidler som ikke lager riper. Bruk IKKE rengjøringssvamper med slipeeffekt eller stålull. Skyll og tørk omhyggelig med en mikrofiberklud etter rengjøringen, slik at alle kalkholdige vannflekker fjernes. Kontroller etter ca. 12 måneder fra installasjonen, at skruene i de forskjellige komponentene er korrekt strammet. Så snart man oppdager den minste funksjonsfeil må det utføres et skriftsmessig ekstraordinært vedlikeholdstiltak.

FORHOLDSREGLER VED BRUK

Unngå uriktig og uegnet bruk av produktet. Eventuelle endringer eller installasjoner som ikke er i samsvar med produsentens anvisninger vil kunne medføre at de forhåndsdefinerte produktkonformitetene ugyldiggjøres.

FI)

tuotteen tunnistetiedot

kauppanimi: **ZEN**

tyyppi: portaat lomitettuilla askelmilla, keskeytymätön porrassyöksyen kierto

käytetyt materiaalit

RAKENNE

kuvas

koostuu metallisista osista (1), jotka kiinnitetään yhteen pulteilla

materiaalit

Fe 370

viimeistely

maalaus uunissa epoksijauheilla

ASKELMAT

kuvas

puiset tuotoillut askelmat (2), jotka asennetaan rakenteeseen pulteilla

materiaalit

koivuvaneri/pyökki

viimeistely

väri: vesipohjainen

pohjamaali: vesipohjainen

viimeistely: vesipohjainen

KAIDE

kuvas

käsittää metalliset pystypinnat (3) kiinnitettyinä askelmiin (2) viisi yhdensuuntaista terästankoa (4) ja puinen käsijohde (5)

materiaalit

pystypinnat (3): Fe 370

terästankoa (4): ruostumaton teräs

kiinnikkeet (6): nailon

käsijohde (5): pyökki

viimeistely

pystypinnat (3): maalaus uunissa epoksijauheilla

käsijohde (5): väri: vesipohjainen

pohjamaali: vesipohjainen

viimeistely: vesipohjainen

PAKOLLINEN PUHDISTUS JA YLLÄPITO

Huolehdi portaiden puhdistuksesta ensimmäisten likatahrojen tai pölyjäämien ilmestyessä sekä säännöllisin väliajoin vähintään joka 6. kuukausi liinalla, joka on kostutettu miedon hankaamattoman pesuaineen ja veden muodostamassa liuoksessa. ÄLÄ koskaan käytä hankaavia tai metallisia sieniä. Puhdistusta ja kuivaa huolellisesti pesun jälkeen mikrokuittuliinalla, jotta poistetaan vesijäämien aikaansaamat kalkkiläikät. Noin 12 kuukauden kuluttua asennuksesta tarkista, että kaikki eri osien ruuvit ja mutterit ovat tiukalla. Mikäli havaitaan pienikin toimintahäiriö, on pakollista suorittaa ennakoimaton huolto, välittömästi ja tarvittavat toimenpiteet kunnolla suorittaen.

KÄYTÖN VAROTOIMET

Vältä tuotteen sopimatonta käyttöä. Mahdolliset väärinkäytökset tai asennukset, jotka eivät vastaa valmistajan ohjeita, voivat aiheuttaa sen, ettei tuote vastaa sen ilmoitettuja ominaisuuksia.

CS)

identifikační údaje o výrobku

obchodní název: **ZEN**

typ: točité schodiště se střídavými stupni a otáčením se sklonem

použité materiály

STRUKTURA

popis

složeno z kovových prvků (1) vzájemně smontovaných pomocí šroubů

materiály

Fe 370

povrchová úprava

epoxidový práškový lak vytvrzený v peci

SCHODKY

popis

dřevěné tvarované stupně (2) přimontované ke konstrukci pomocí šroubů

materiály

březová překližka / buk

povrchová úprava

barva: na bázi vody

podkladový nátěr: na bázi vody

krycí nátěr: na bázi vody

ZÁBRADLÍ

popis

složeno z kovových vertikálních sloupků (3) upevněných ke stupňům (2), z 5 rovnoběžných ocelových tyčí (4) a z dřevěného madla (5)

materiály

sloupky (3): Fe 370

tyče (4): nerezová ocel

spojovací prvky (6): nylon

madlo (5): buk

povrchová úprava

sloupky (3): epoxidový práškový lak vytvrzený v peci

madlo (5): barva: na bázi vody

podkladový nátěr: na bázi vody

krycí nátěr: na bázi vody

POVINNÉ ČIŠTĚNÍ A ÚDRŽBA

Očistěte závitý jakmile se objeví nečistoty a usazený prach, nejméně však jednou za 6 měsíců. Čištění proveďte měkkým hadrem namočeným do vody s neabrazivním a neagresivním čisticím prostředkem. NIKDY nepoužívejte drátěnky. Po vyčištění důkladně otřete hadrem z mikrovláken, aby se odstranily odlesky způsobené vápnen ve vodě. Asi po 12 měsících po instalaci, zkontrolujte utažení šroubů všech součástí. Pokud dojde k jakémukoli i malému poruše, je nezbytné okamžitě a profesionálně provést mimořádnou údržbu.

BEZPEČNOSTNÍ POKYNY

Vyhýbat se nesprávnému a nevhodnému použití výrobku. Eventuální poškození nebo instalace neodpovídající instrukcím výrobce mohou porušit předem sjednané kvality výrobku.

SK)

identifi kačné údaje o výrobku

obchodný názov: **ZEN**

typ: vnútorné schodisko so striedavým tvarom schodiskových stupňov a otočením ramien so sklonom

použité materiály

KONŠTRUKCIA

opis

skladá sa z kovových dielov **(1)** spájaných skrutkami

materiály

Fe 370

povrchová úprava

lakovanie s vypaľovanými epoxidovými práškami

SCHODISKOVÉ STUPNE

opis

drevené tvarované schodiskové stupne **(2)** pripevnené ku konštrukcii skrutkami

materiály

brezový/bukový vrstvený materiál

povrchová úprava

farba: vodná báza

podkladová vrstva: vodná báza

povrchová úprava: vodná báza

ZÁBRADLIE

opis

skladá sa zo zvislých kovových stĺpikov **(3)** upevnených k schodiskovým stupňom **(2)**, 5 pozdĺžnych okrúhlych ocelových tyčí **(4)** a dreveného madla **(5)**

materiály

stĺpiky **(3)**: Fe 370

okružle ocelové tyče **(4)**: nehrdzavejúca ocel

upevnenia **(6)**: nylon

madlo **(5)**: buk

povrchová úprava

stĺpiky **(3)**: lakovanie s vypaľovanými epoxidovými práškami

madlo **(5)**: farba: vodná báza

podkladová vrstva: vodná báza

povrchová úprava: vodná báza

POVINNÉ ČISTENIE A ÚDRŽBA

Závity vyčistite hneď, ako sa na nich objavia známky znečistenia alebo nánosy prachu a aspoň každých 6 mesiacov používania pomocou vlhkej utierky a špecifických, neabrazívnych a neagresívnych čistiacich prostriedkov. **NIKDY** nepoužívajte abrazívne drôtenky. Po vyčistení dokonale vysušte povrch utierkou z mikro vlákien, aby sa odstránili zvyšky vodného kameňa, ktorý sa tvorí prítomnosťou vápnika vo vode. Približne 12 mesiacov od dátumu inštalácie skontrolujte, či sú dotiahnuté skrutky na všetkých komponentoch. Keď sa vyskytne sebemenšia porucha, povinne sa musí okamžite a profesionálne vykonať špeciálna údržba.

OPATRENIA PRE POUŽÍVANIE

Nepoužívajte spôsobom, ktorý nie je pre výrobok vhodný a primeraný. V dôsledku neodborných zásahov alebo montáže, ktoré nie sú v súlade s pokynmi výrobcu, môžu byť stanovené zhody výrobku neplatné.



Zen
D.U.M.
03/2021

zen

Fontanot S.p.A.
Sede legale ed amministrativa
via P. Paolo Pasolini, 6
47853 Cerasolo Ausa
Rimini, Italy

tel. +39.0541.90.61.11
fax. +39.0541.90.61.24
info@fontanot.it
www.fontanot.it

cod. 066632000

Design: Centro Ricerche Fontanot

Sistema aziendale Fontanot S.p.A.
certificato CSQ ISO-9001

