

# 67000

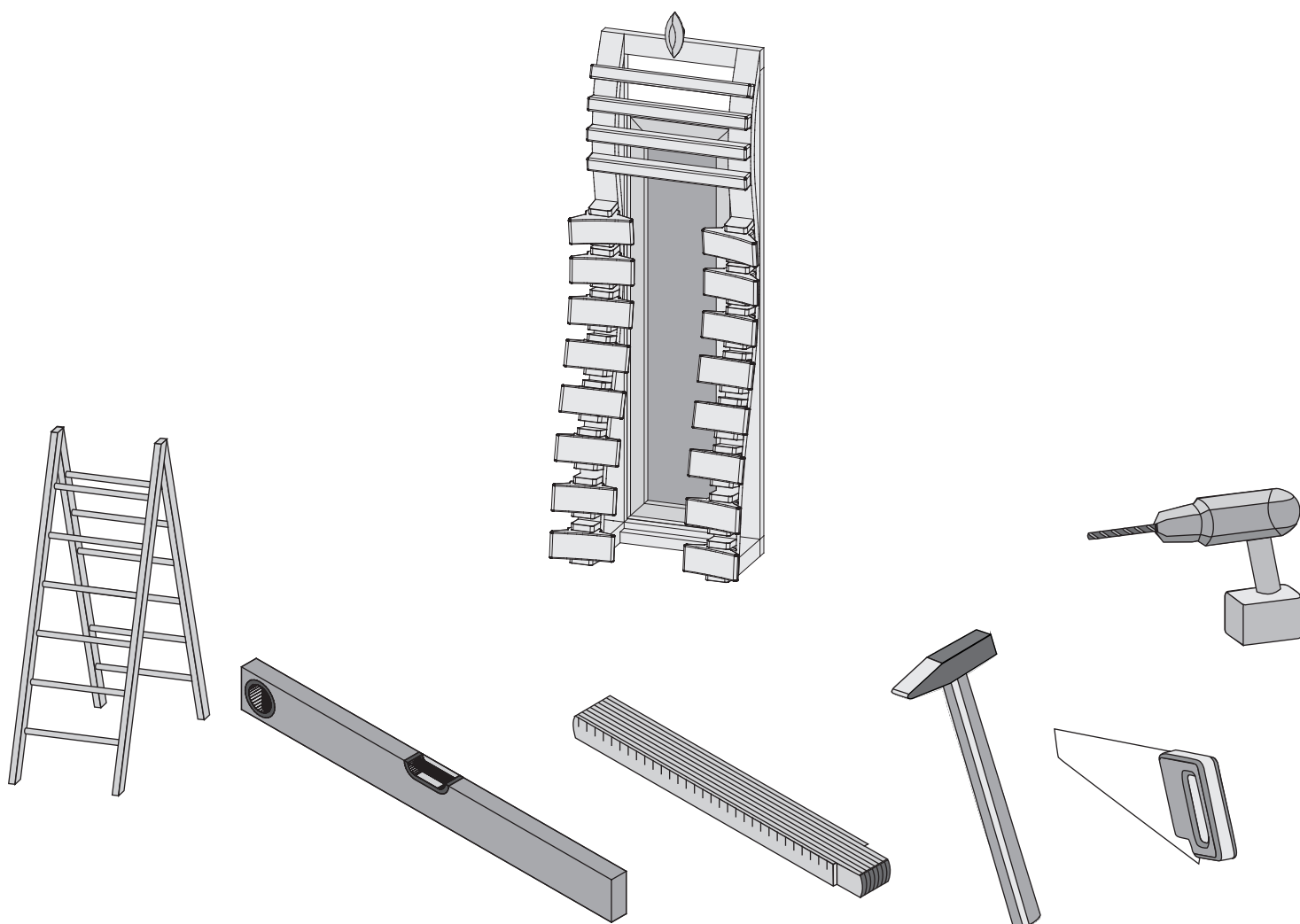

 **Aufbauanleitung**

 **notice de montage**

 **Building Instructions**

 **montagehandleiding**

 **Instrucciones de construcción**

 **Istruzioni per il montaggio**

 **Montážní návod**

 **Service-Hotline: +49 421 38693 33**



Vergleichen Sie zuerst die Materialliste mit Ihrem Paketinhalt! Bitte haben Sie Verständnis, dass Beanstandungen nur im nicht aufgebauten Zustand bearbeitet werden können!



Commencez par comparer la liste du matériel avec le contenu de votre paquet! Sachez que nous traitons uniquement les réclamations concernant le matériel à l'état non monté!



First compare the list of materials with your package contents! Please understand that complaints can be processed in the non-built status only!



Vergelijk eerst de lijst van materialen met de inhoud van uw pakket! Reclamaties kunnen alleen in behandeling worden genomen zolang de onderdelen nog niet zijn gemonteerd!



En primer lugar, compare la lista de material con el contenido del paquete. Rogamos entienda que las reclamaciones sólo pueden ser tramitadas antes de montar el objeto!



Confrontate questa distinta materiali prima con il contenuto del pacchetto! Vi preghiamo di comprendere che eventuali reclami possono essere accolti solo prima del montaggio!



67000

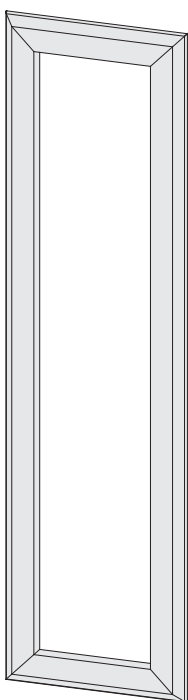

1 x R1

720 x 197 x 17mm

ID 67003

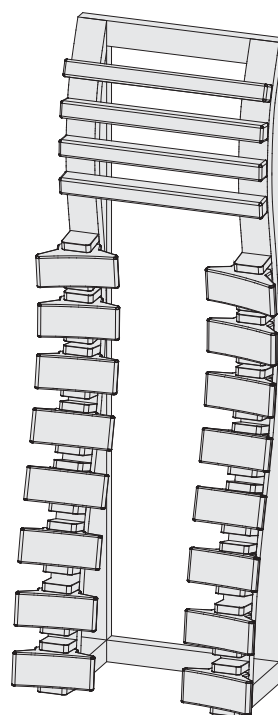

1 x R2

720 x 275 x 195mm

ID 66999

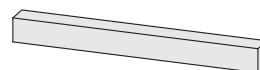

1 x B1

195 x 19 x 19mm

ID 67226



1 x F1

4 x 35mm

ID 3687

10 x S1



ID 26116



10 x

4,5 x 40mm

ID 26285

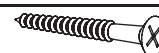

4 x

4 x 25mm

ID 5841



**Hinweis**

Die Verwendung von Infrarotstrahler darf nicht zusammen mit Saunaöfen erfolgen.



**renseignement**

L'utilisation d'émetteurs infrarouges ne peut être combiné avec des radiateurs.



**warning**

The use of infrared emitters may not be combined with heaters.



**waarschuwing**

Het gebruik van infrarood stralers mag niet worden gecombineerd met kachels.



**la nota**

El uso de emisores de infrarrojos no se puede combinar con los calentadores.









**avvertenza**

L'uso di emettitori infrarossi non può essere combinata con i riscaldatori.

68mm Saunen

40mm Saunen

-  Einbau nur an der Rückwand
-  En utilisant seulement la paroi arrière
-  Using only the rear wall
-  Met alleen de achterwand
-  Utilizando sólo la pared posterior
-  Utilizzando solo la parete posteriore

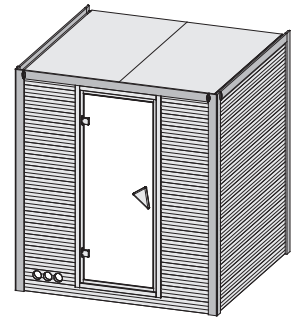
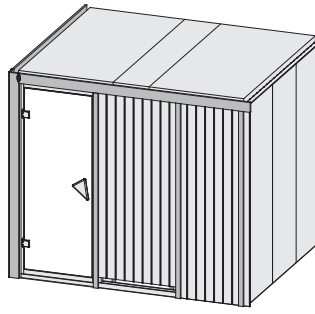

01 ... 06



07 ... 11

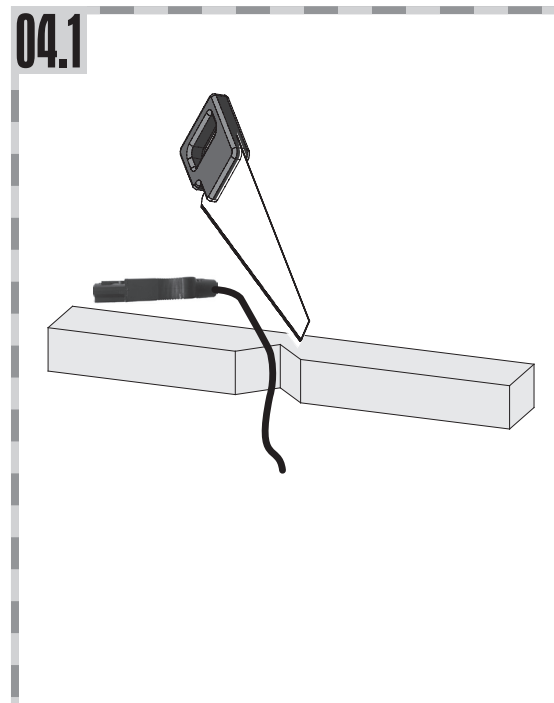
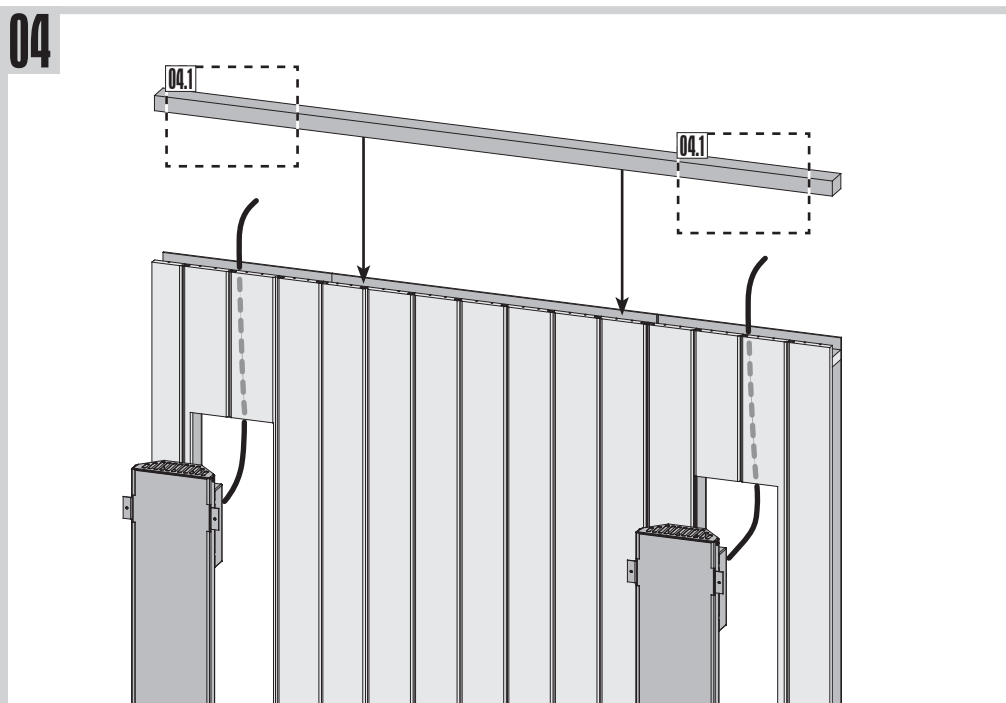
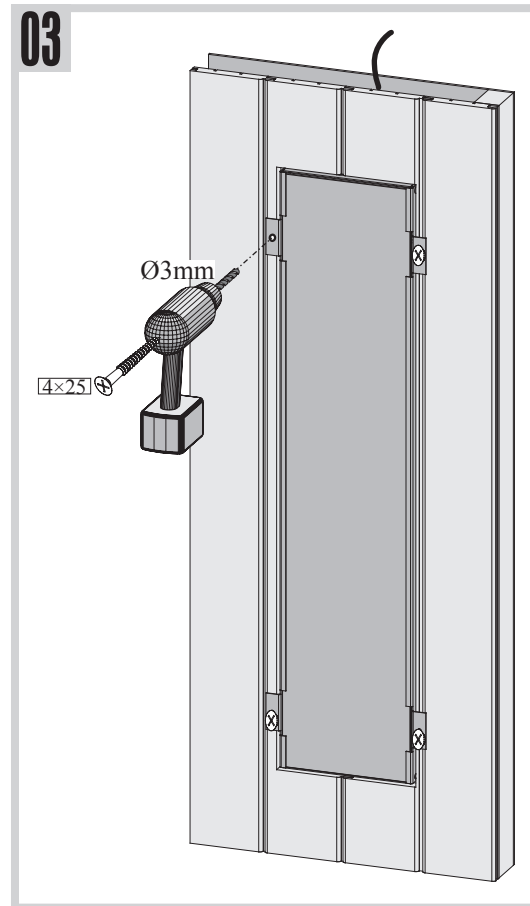
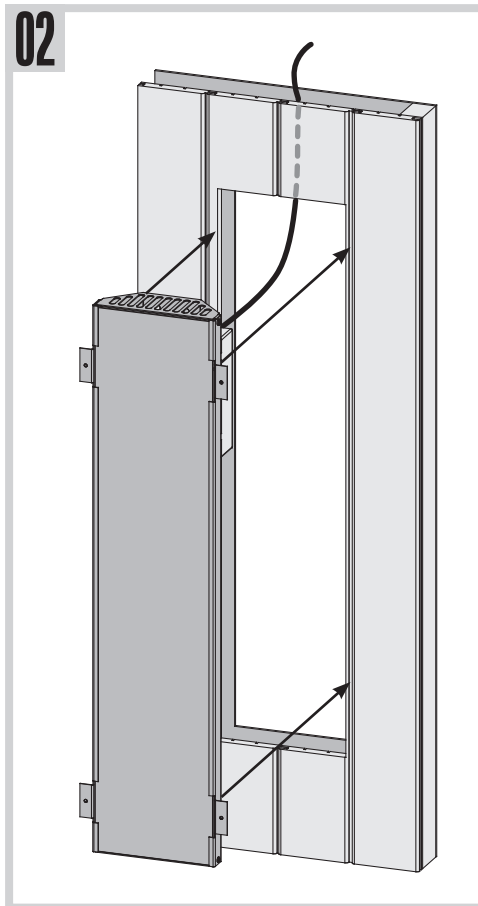
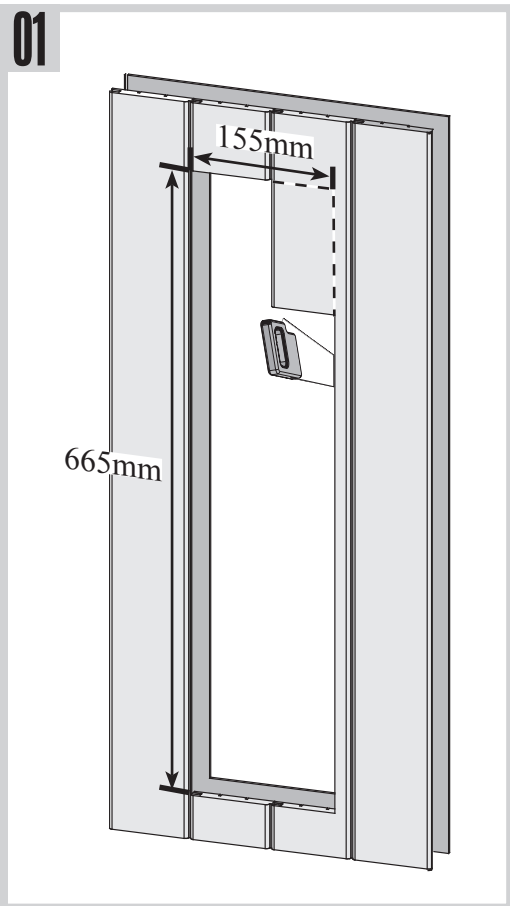

05

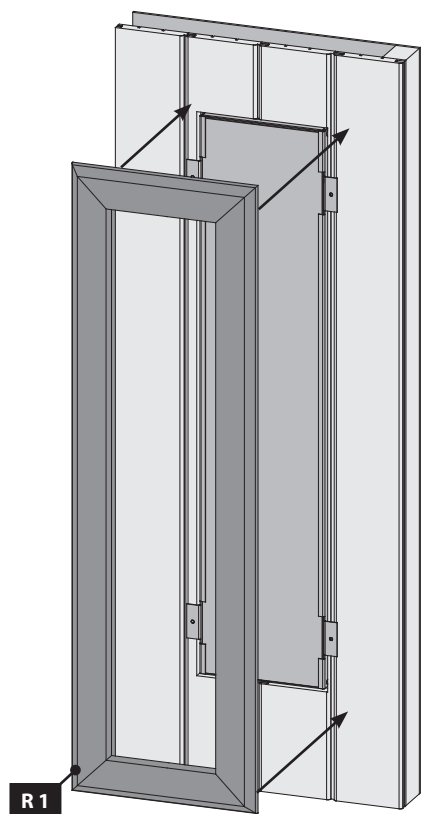

06

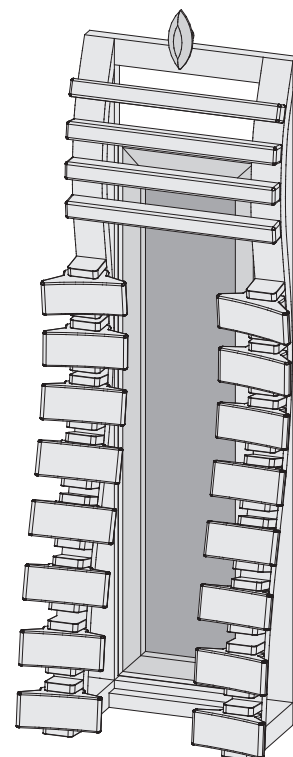
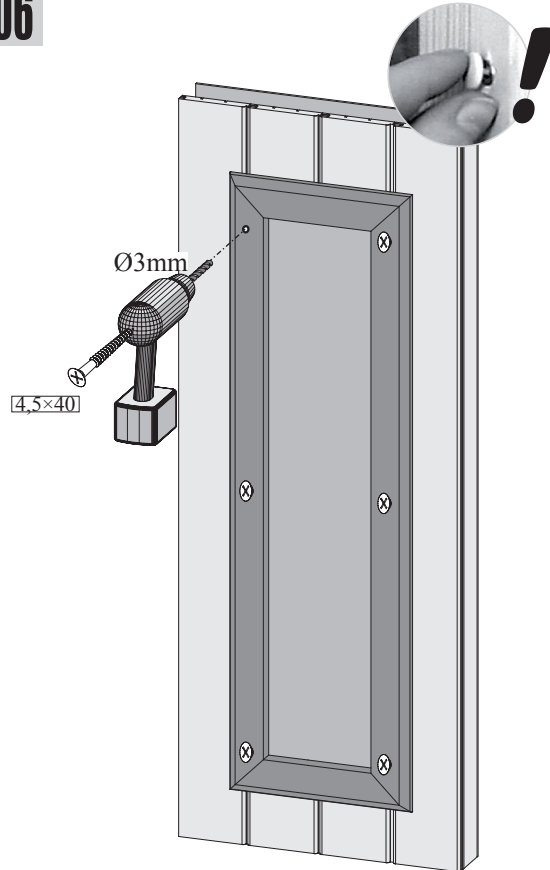

⇒ 12 ... 14



**Hinweis**



**renseignement**



**warning**



**waarschuwing**



**la nota**



**avvertenza**

Das Reinigen mit Dampfreinigern, Hochdruckreinigern oder Spritzwasser ist nicht zulässig.

Nettoyage avec des nettoyeurs à vapeur, nettoyeurs à haute pression ou éclaboussure n'est pas permis.

Cleaning with steam cleaners, high pressure cleaners or splash water is not allowed.

Reinigen met stoom reinigingsmiddelen, is Hogedruk Reinigers of spuiten water niet toegestaan.

La limpieza con limpiadores de vapor, limpiadores de alta presión o el roción no está permitido.

Pulizia con pulitori a vapore, idropultrici o spruzzo dell'acqua non è consentito.

07

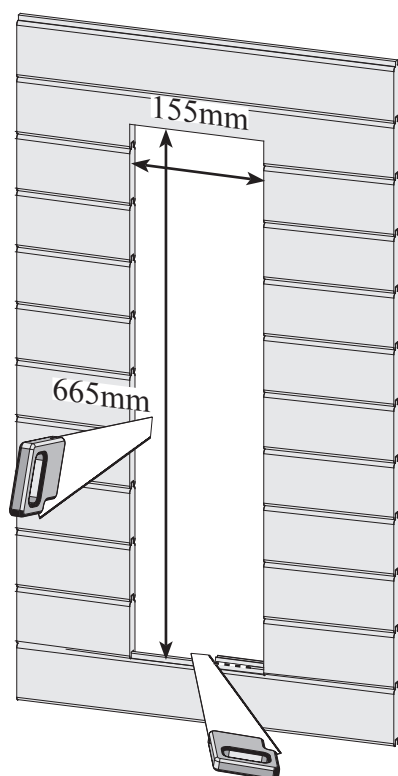

08

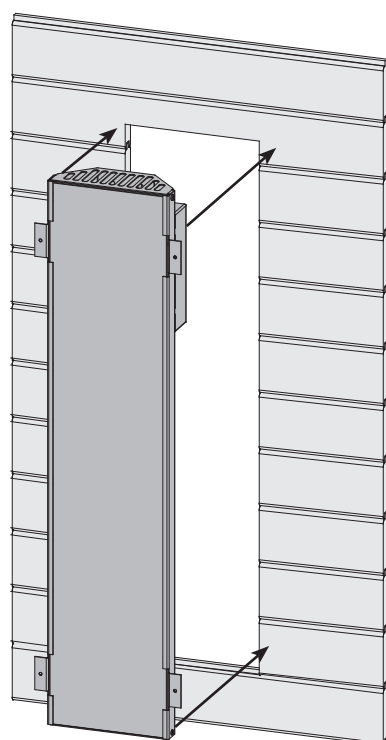

09

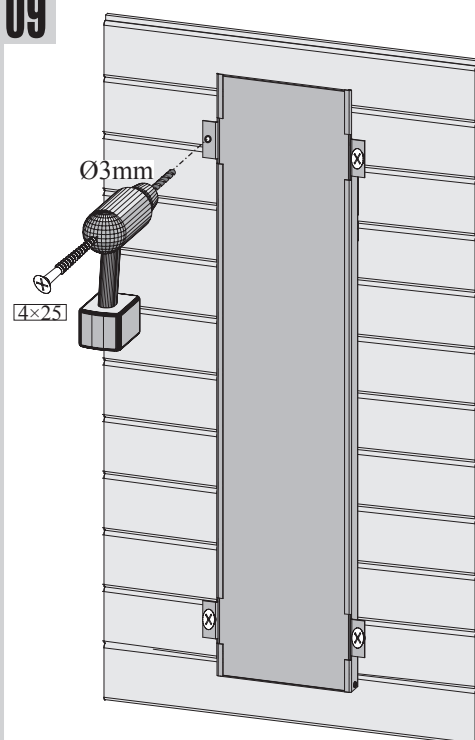

10

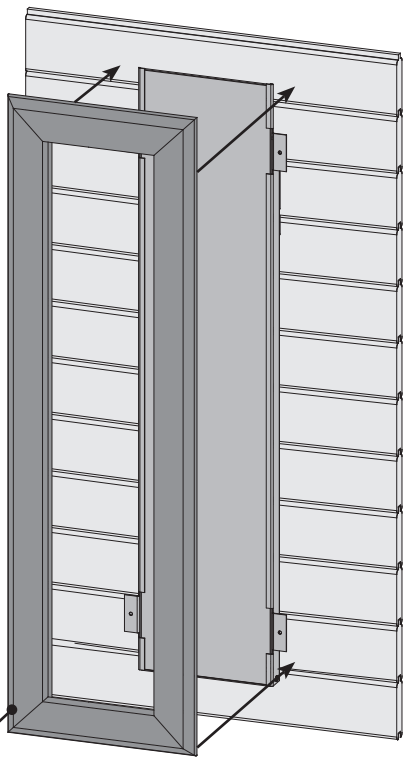

11

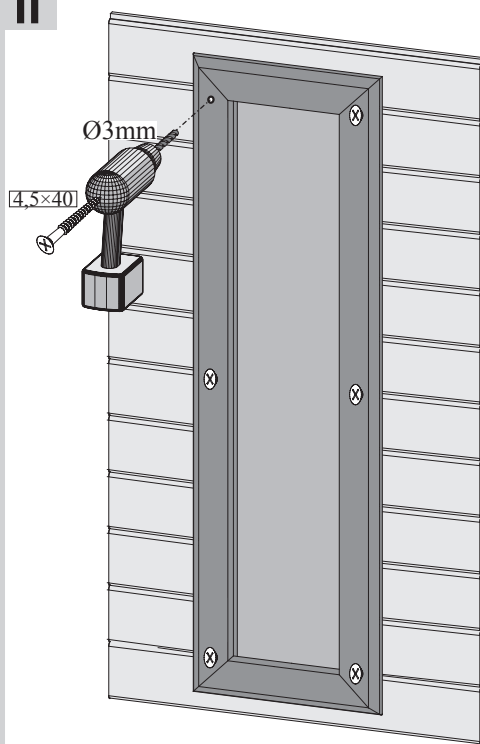

 **Das Steuergerät nach beiliegender Montageanleitung montieren**

Dabei bitte folgende **Hinweise** beachten:

Ihr Set ist für Saunen ausgelegt, die keine Kabeldurchführungen in den Wänden haben. Aus diesem Grund sollten Sie an der Stelle an der später Ihr Steuergerät sitzen soll, eine Kabeldurchführung einsetzen. Bohren Sie dafür ein Loch ( $\text{Ø } 10\text{mm}$ ) durch die Kabinenwand und ein weiteres oben durch das Kabinendach. Durch diese führen Sie das Kabel von der Decke innen an der Kabinenwand entlang und wieder durch die Wand hinaus zum Steuergerät. Den Ausschnitt sowie die Kabel verdecken Sie mit der Kabelleiste K1. Sie wird mit 4 Spax  $4,5 \times 40\text{mm}$  verschraubt und mit den Kappen S1 abgedeckt.

12

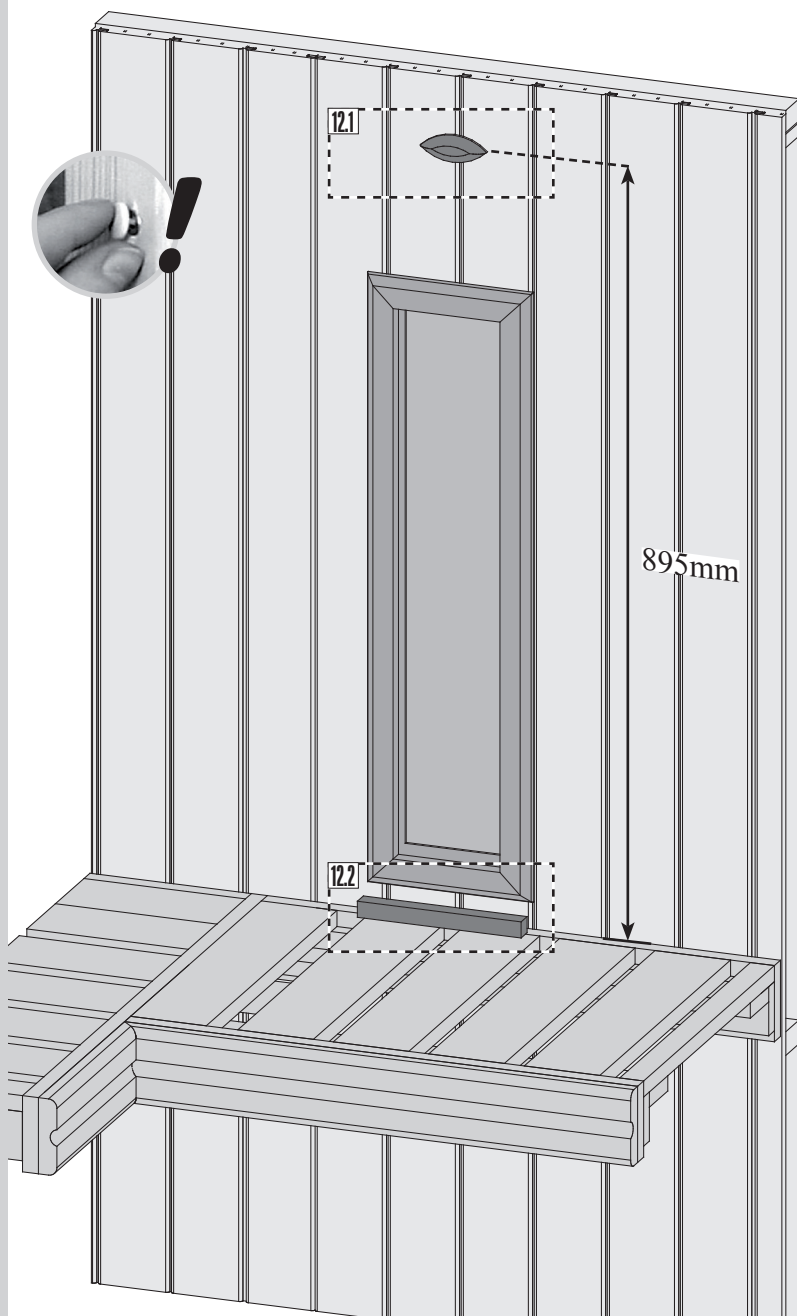

12.1

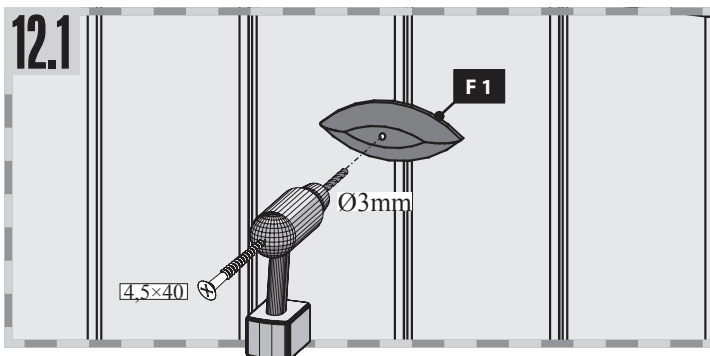

12.2

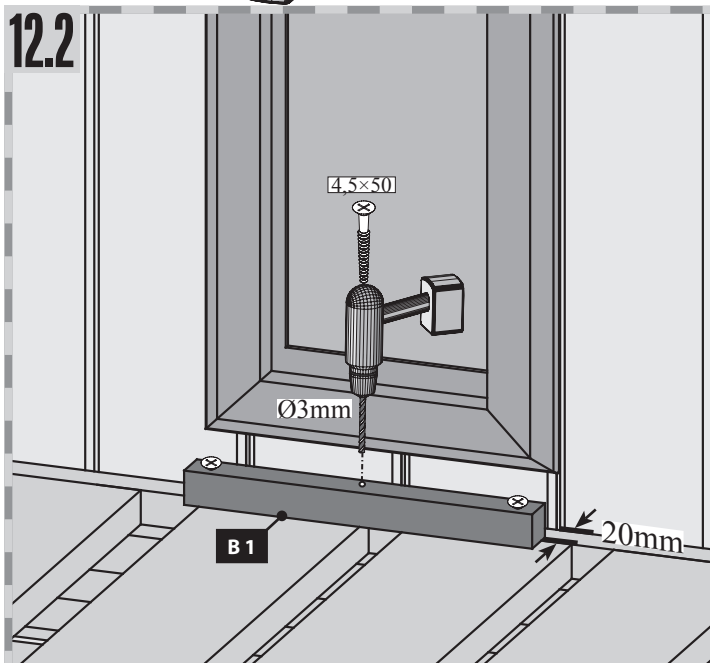

13



14

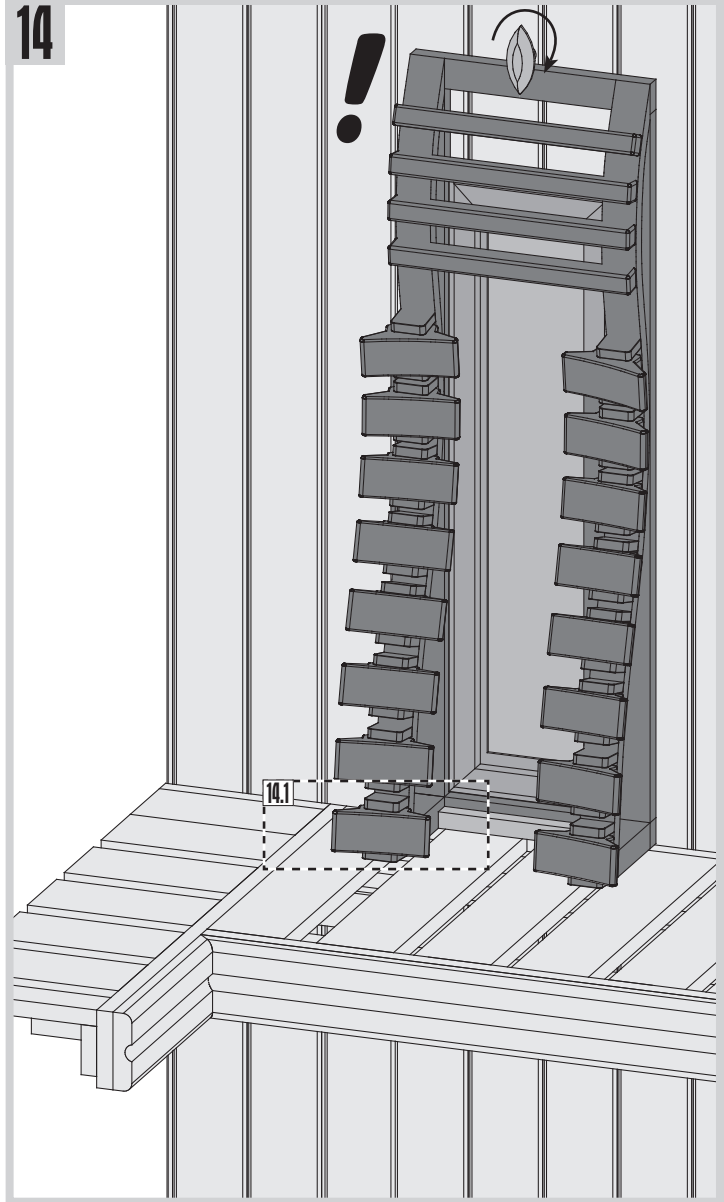

14.1

