

84588

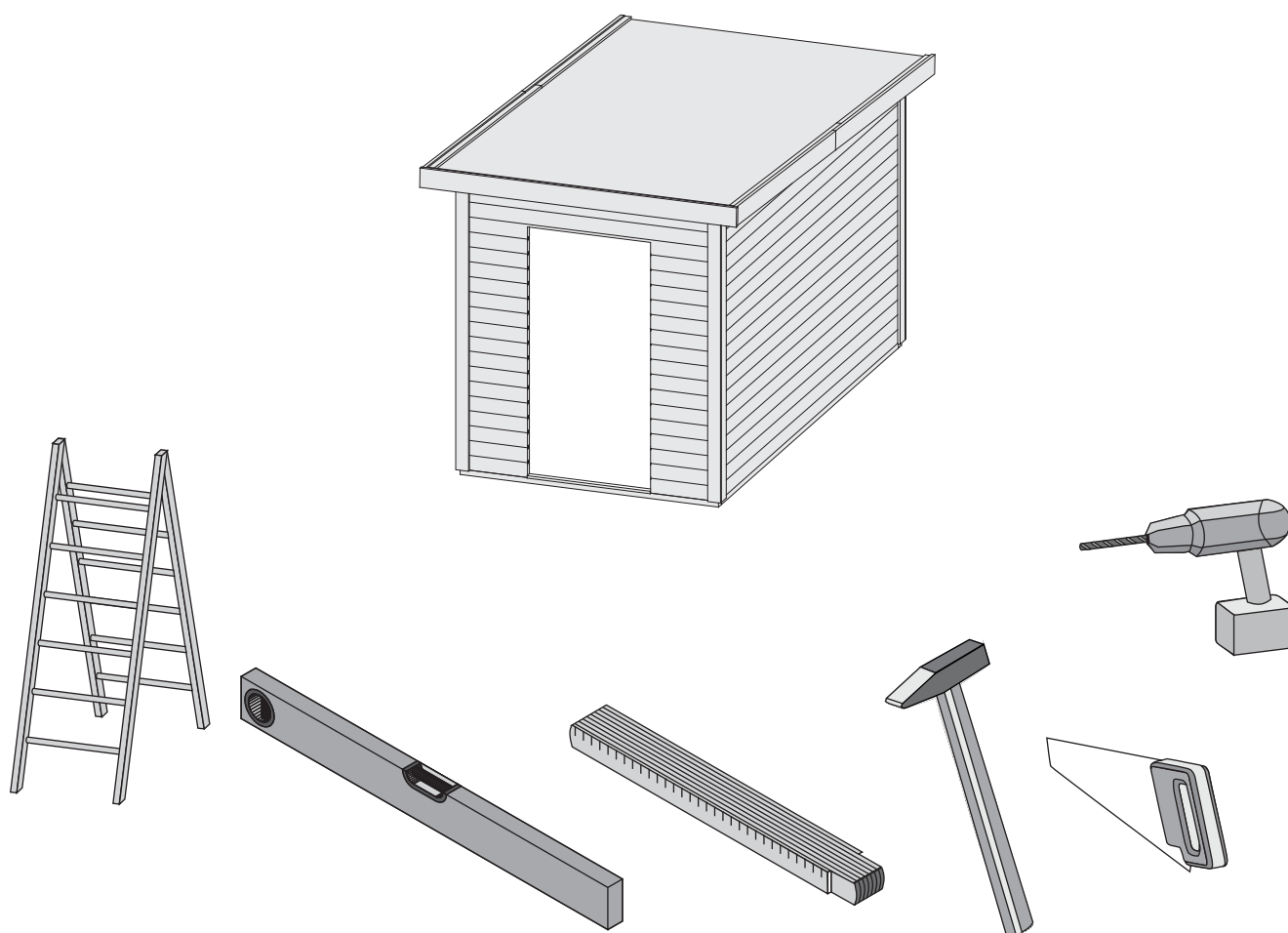

 **Aufbauanleitung**

 **Building Instructions**

 **notice de montage**

 **montagehandleiding**

 **Montagevejledning**

 **Instrucciones de construcción**

 **Istruzioni per il montaggio**

 **Montážní návod**



+49 421 38693 33



Vergleichen Sie zuerst die Material-liste mit Ihrem Paketinhalt! Bitte haben Sie Verständnis, dass Beanstandungen nur im nicht aufgebauten Zustand bearbeitet werden können!



Vergelijk eerst de lijst van materialen met de inhoud van uw pakket! Reclamaties kunnen alleen in behandeling worden genomen zolang de onderdelen nog niet zijn gemonteerd!



Confrontate questa distinta materiali prima con il contenuto del pacchetto! Vi preghiamo di comprendere che eventuali reclami possono essere accolti solo prima del montaggio!



First compare the list of materials with your package contents! Please understand that complaints can be processed in the non-built status only!



Start med at kontrollere materialelisten med indholdet af den leverede pakke! Vi gør venligst opmærksom på at reklamationer kun kan behandles for materialer som ikke er blevet bearbejdet!



Nejprve přezkontrolujte obsah balení podle materiálového listu! Mějte pochopení pro to, že případnou reklamaci se můžeme zabývat pouze tehdy, když díly nebudou smontované! Za pomoci tohoto seznamu můžete jednotlivé díly přiřadit k montážnímu návodu.



Commencez par comparer la liste du matériel avec le contenu de votre paquet! Sachez que nous traitons uniquement les réclamations concernant le matériel à l'état non monté!



En primer lugar, compare la lista de material con el contenido del paquete. Rogamos entienda que las reclamaciones sólo pueden ser tramitadas antes de montar el objeto!

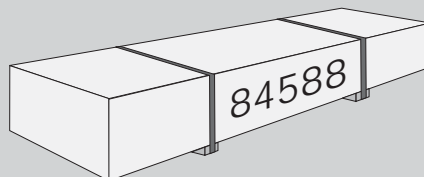

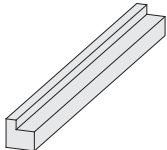
				
2 x A1	555 x	45 x	45 mm	ID 40301
2 x A2	1100 x	45 x	45 mm	ID 40302

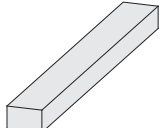
				
1 x B1	1920 x	20 x	4 mm	ID 20799
2 x B2	1810 x	90 x	16 mm	ID 71513
1 x B3	780 x	36 x	18 mm	ID 65721
1 x B4	910 x	45 x	18 mm	ID 35734
2 x B5	800 x	45 x	18 mm	ID 24796
4 x B6	1809 x	45 x	18 mm	ID 21831
8 x B7	2100 x	45 x	18 mm	ID 19547
1 x B8	300 x	95 x	18 mm	ID 19130
4 x B9	480 x	95 x	18 mm	ID 20930
4 x B10	565 x	95 x	18 mm	ID 15498
8 x B11	2300 x	95 x	18 mm	ID 16177
4 x B12	1940 x	190 x	26 mm	ID 84603
1 x B13	2340 x	190 x	26 mm	ID 63006
2 x B14	800 x	58 x	28 mm	ID 15493
3 x B15	1940 x	58 x	28 mm	ID 15504
4 x B16	60 x	36 x	36 mm	ID 5512
6 x B17	2185 x	36 x	36 mm	ID 76359
7 x B18	1910 x	60 x	40 mm	ID 29452
2 x B19	3690 x	60 x	40 mm	ID 28688

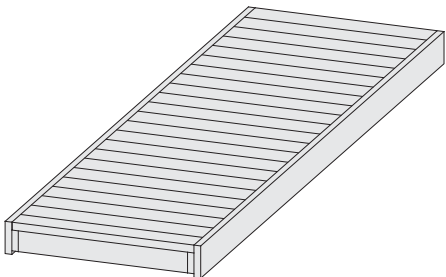
				
2 x L1	1810 x	550 x	90 mm	ID 43994

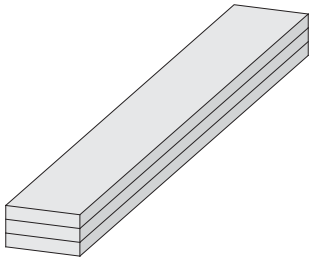
				
6 x P1	175 x	95 x	54 mm	ID 63030
3 x P2	1843 x	95 x	54 mm	ID 22596

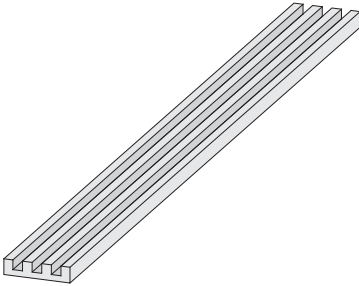
				
1 x E1	1820 x	140 x	26 mm	ID 26480

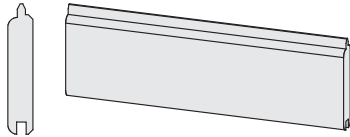
				
26 x R1	3900 x	96 x	16 mm	ID 69916
40 x R2	1845 x	96 x	19 mm	ID 18474

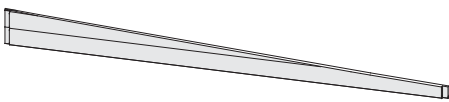
				
1 x G1	3550 x	228 x	40 mm	ID 84604

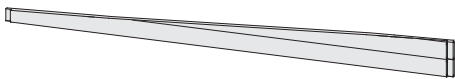
				
1 x G2	3550 x	228 x	40 mm	ID 84605

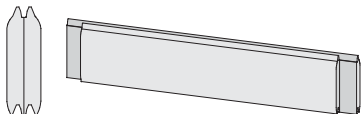
				
3 x W1	1845 x	121 x	40 mm	ID 65716
22 x W2	1881 x	121 x	40 mm	ID 21429
36 x W3	3550 x	121 x	40 mm	ID 74671

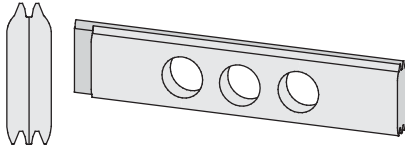
				
1 x W4	530 x	121 x	40 mm	ID

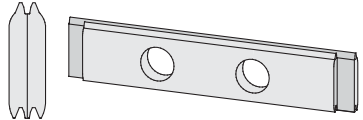
				
1 x W5	1881 x	121 x	40 mm	ID 21864

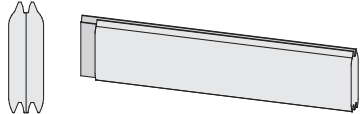
				
16 x W6	485 x	121 x	40 mm	ID 63013
16 x W7	530 x	121 x	40 mm	ID 65712

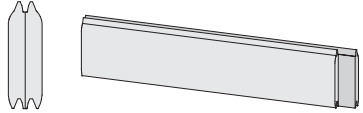
				
16 x W8	485 x	121 x	40 mm	ID 63014
17 x W9	530 x	121 x	40 mm	ID 65713

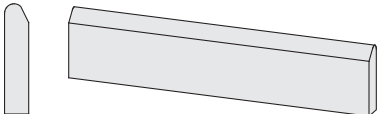
				
1 x C1	400 x	95 x	18 mm	ID 27167

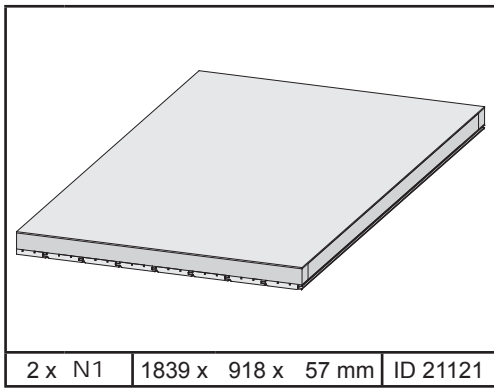

2 x N1 | 1839 x 918 x 57 mm | ID 21121

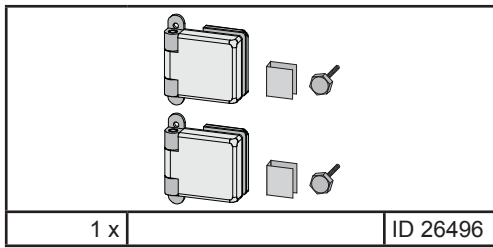

1 x | ID 26496

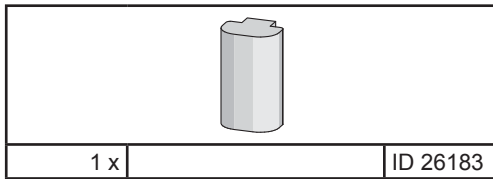

1 x | ID 26183

	35 x	4 x 30 mm	ID 3686
	315 x	4 x 35 mm	ID 3687
	305 x	4 x 40 mm	ID 21925
	45 x	4 x 50 mm	ID 3688
	15 x	4 x 60 mm	ID 21207
	35 x	4 x 70 mm	ID 3689
	25 x	4,5 x 80 mm	ID 9204
	20 x	6 x 80 mm	ID 47558
	105 x	6 x 90 mm	ID 26715
	30 x	6 x 100 mm	ID 11749

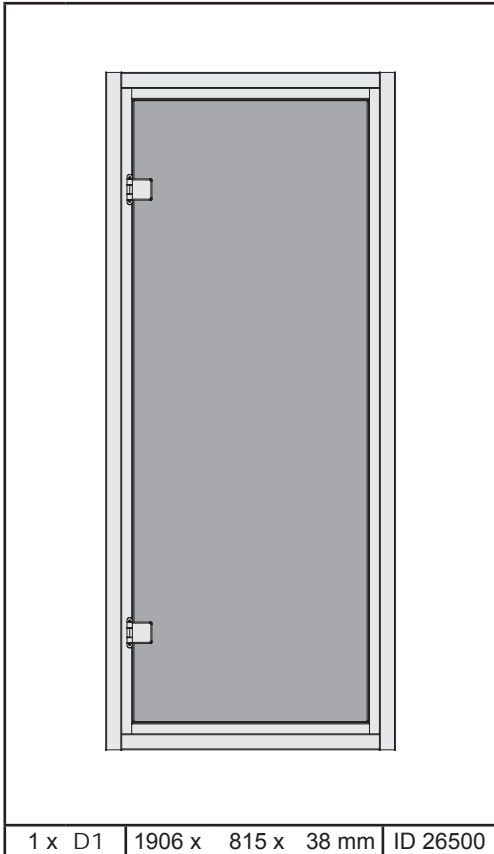

1 x D1 | 1906 x 815 x 38 mm | ID 26500

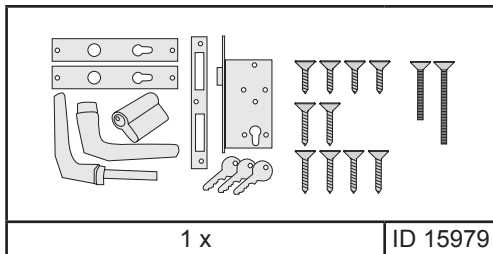

1 x | ID 15979

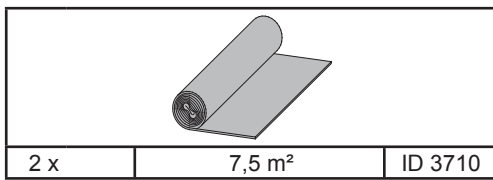

2 x | 7,5 m² | ID 3710

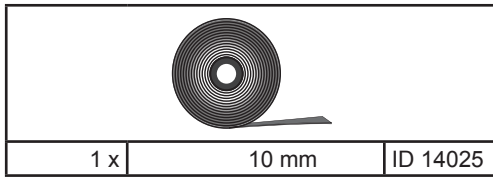

1 x | 10 mm | ID 14025

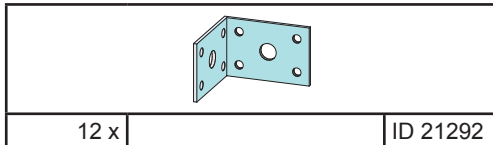

12 x | ID 21292

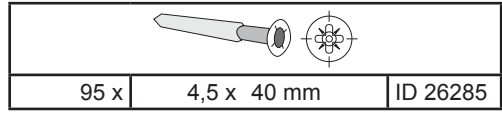

95 x | 4,5 x 40 mm | ID 26285

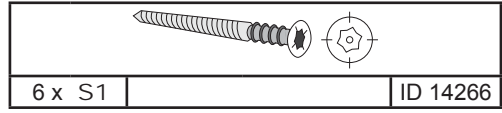

6 x S1 | ID 14266

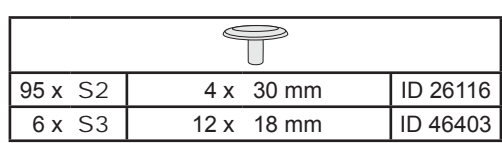

95 x S2 | 4 x 30 mm | ID 26116
6 x S3 | 12 x 18 mm | ID 46403



600 x | ID 5621

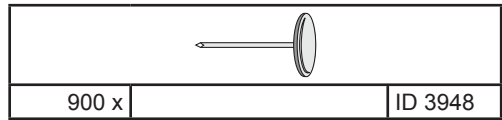

900 x | ID 3948

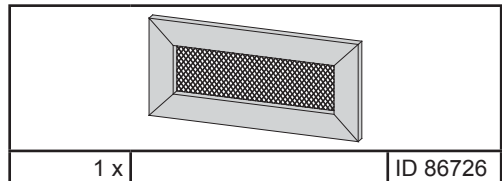

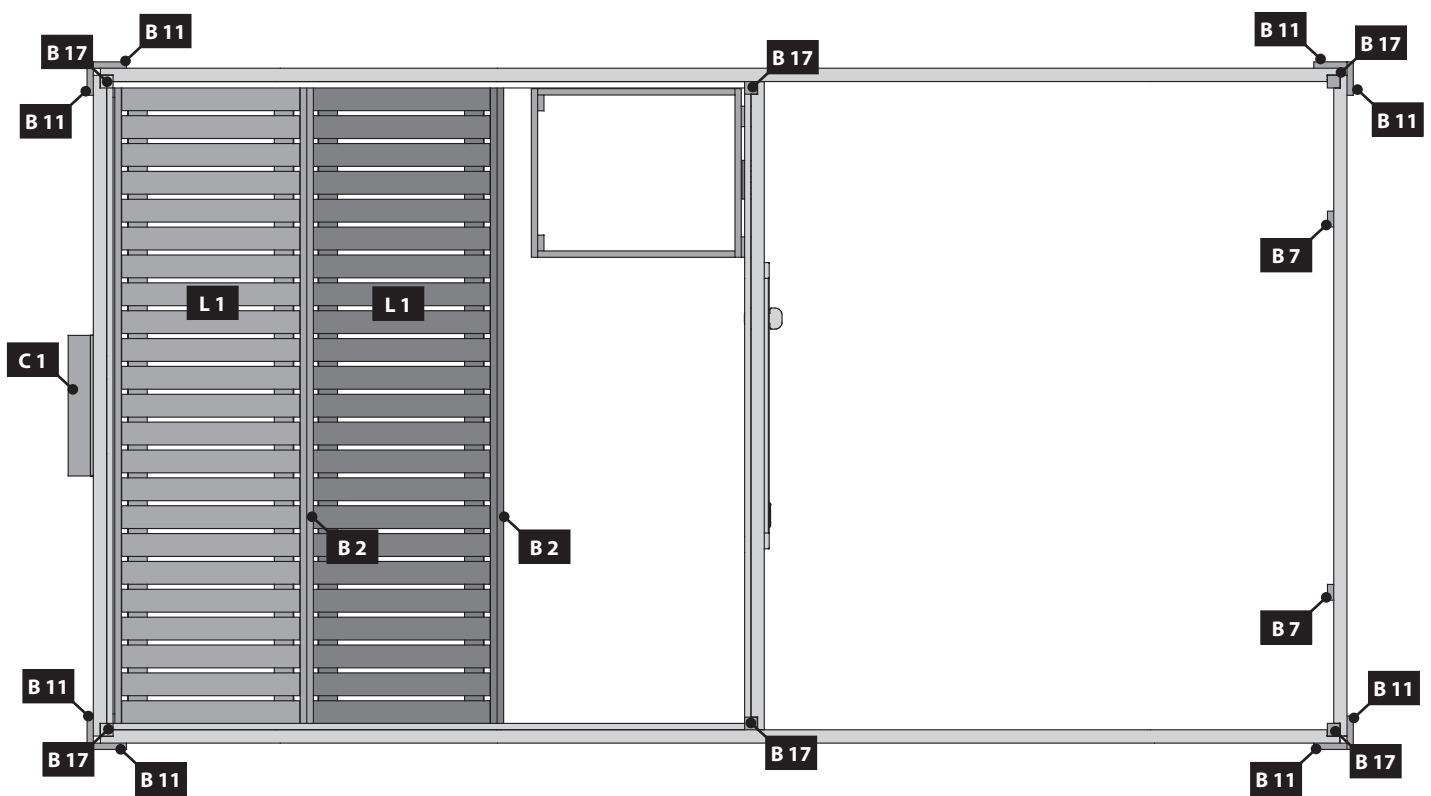

1 x | ID 86726



 Übersicht
 Overview
 enquête

 overzicht
 undersøgelse
 estudio

 sondaggio
 přehled

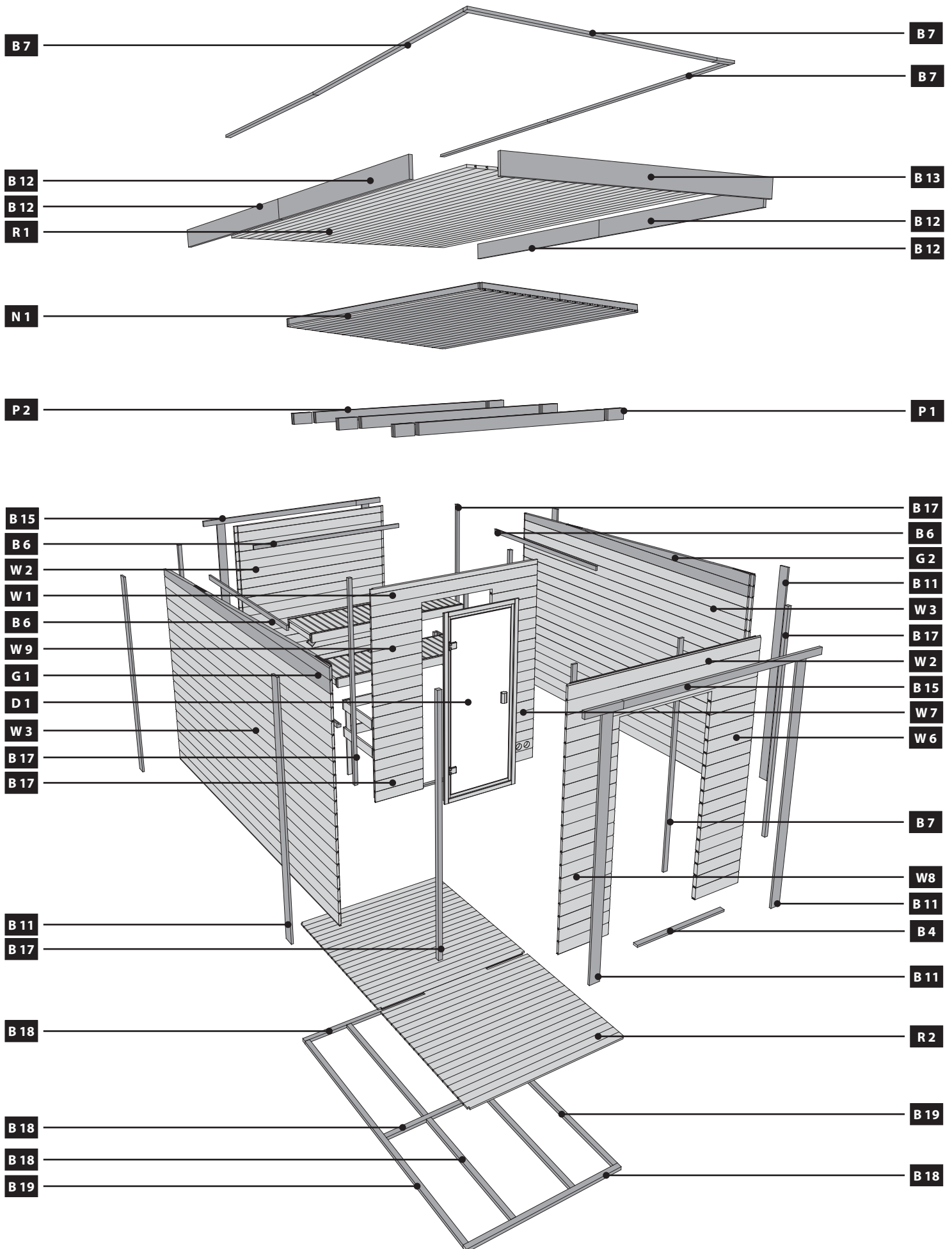

*

 Nicht im Lieferumfang enthalten

 No forman parte del suministro

 Niet bijgeleverd

 Non incluso

 Not included

 V ceně není zahrnuto

 Non comprises dans la livraison

01

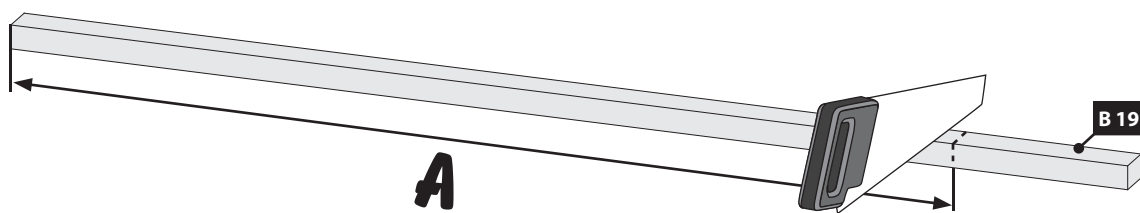

02

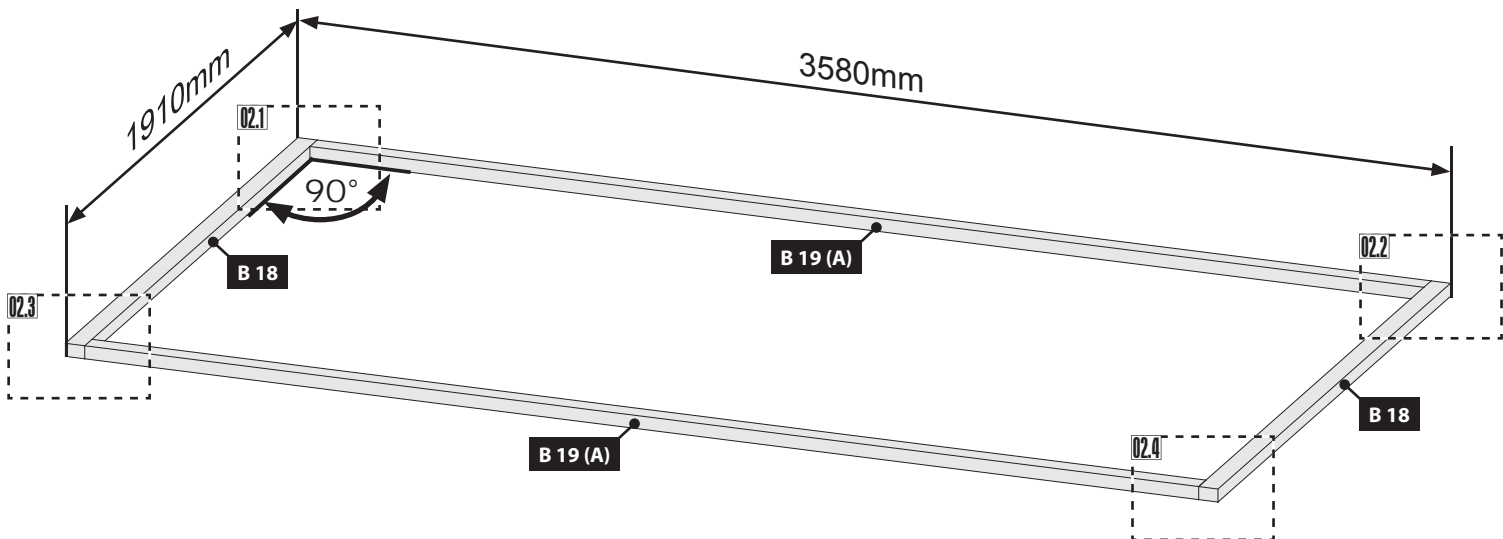
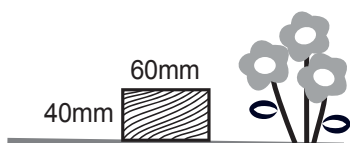

Ø3mm 4,5×80

02.1

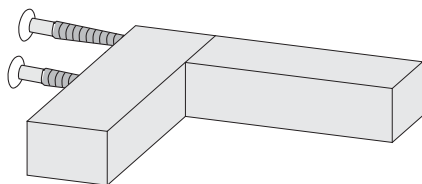

Ø3mm 4,5×80

02.2

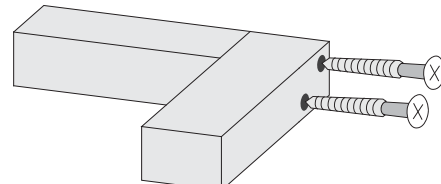

Ø3mm 4,5×80

02.3

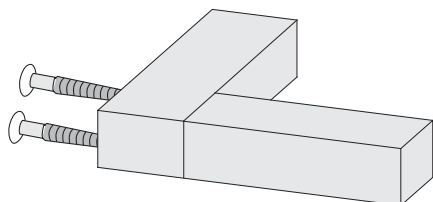

Ø3mm 4,5×80

02.4

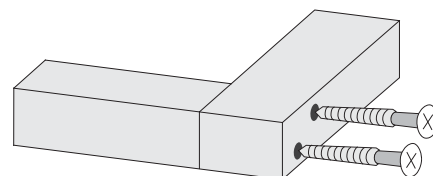

03

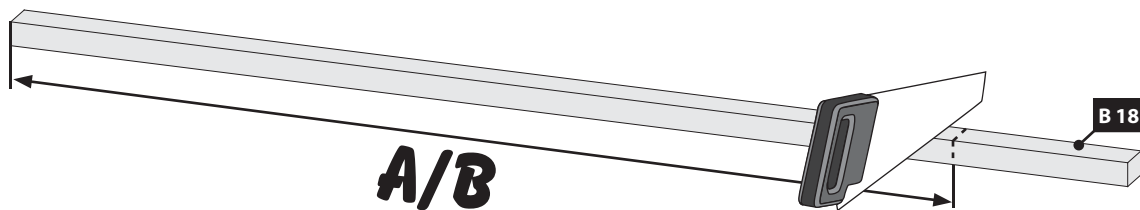



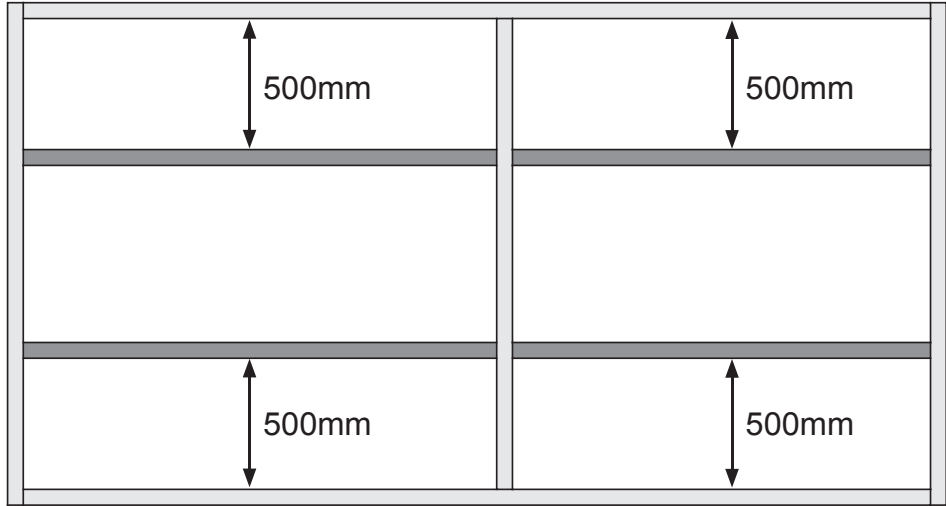
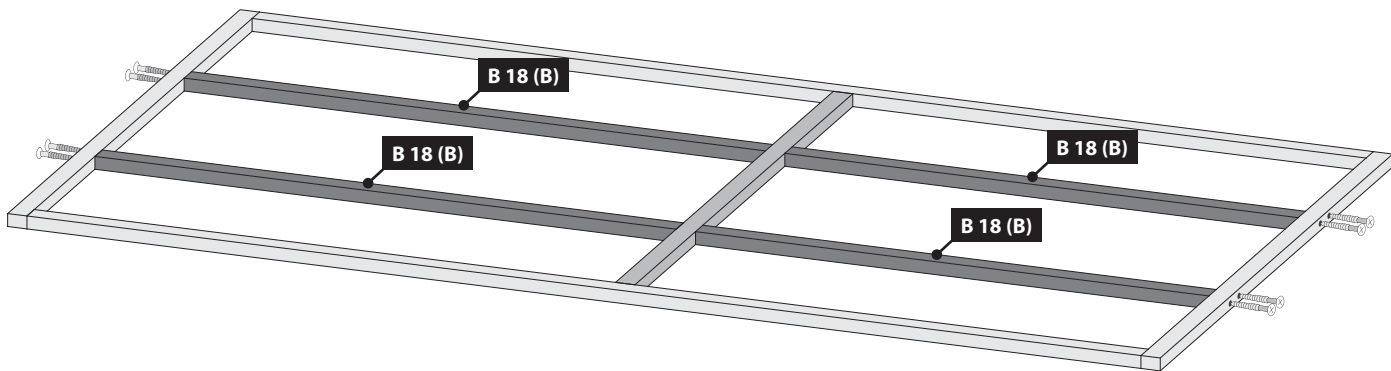
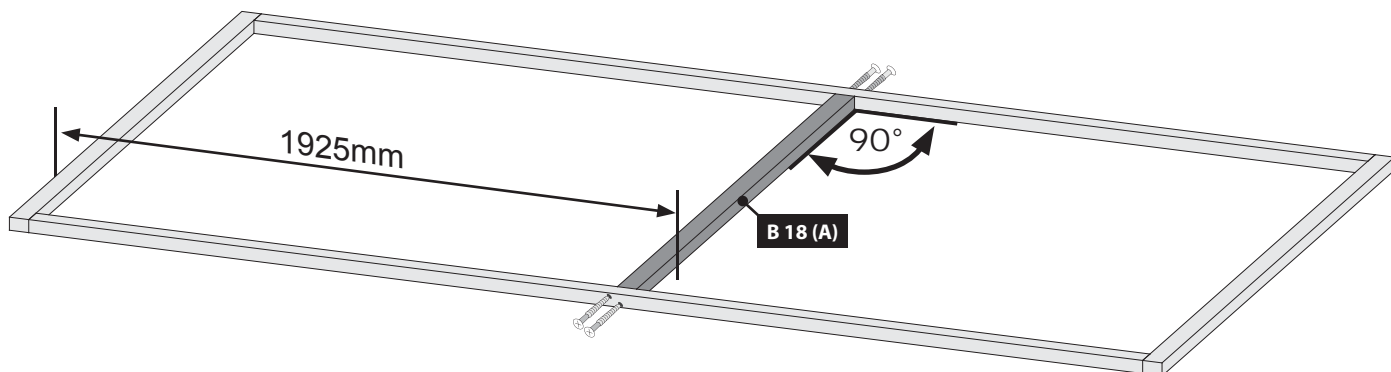
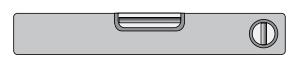
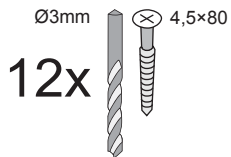
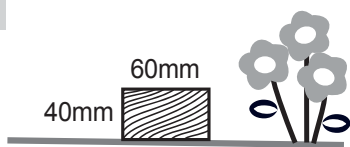

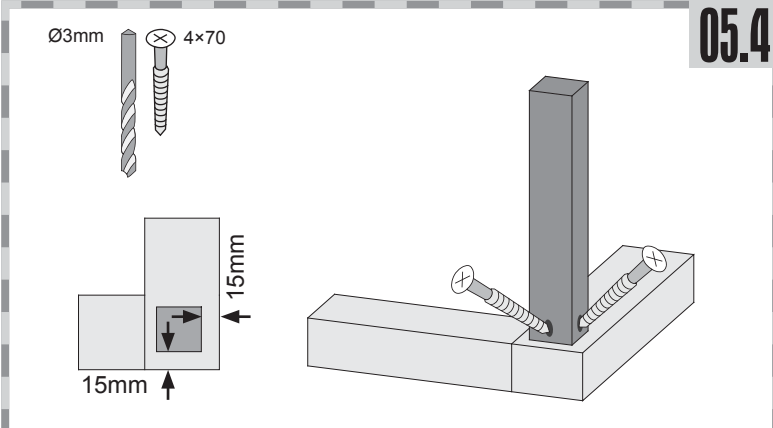
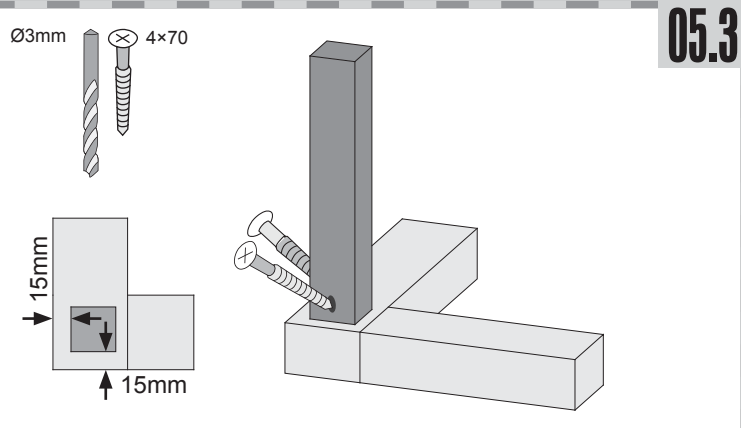
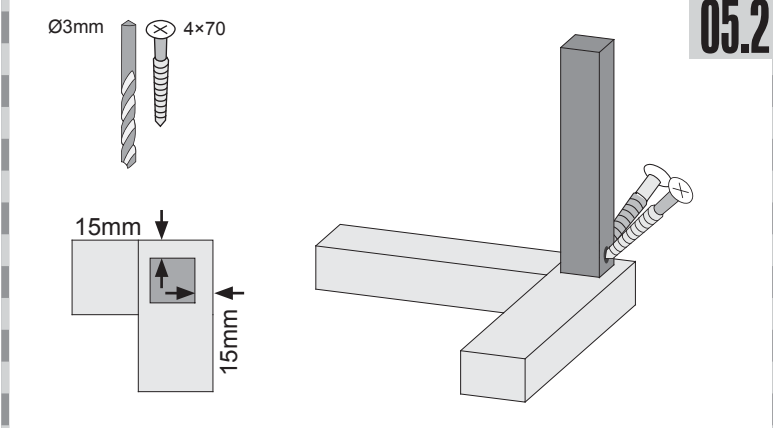
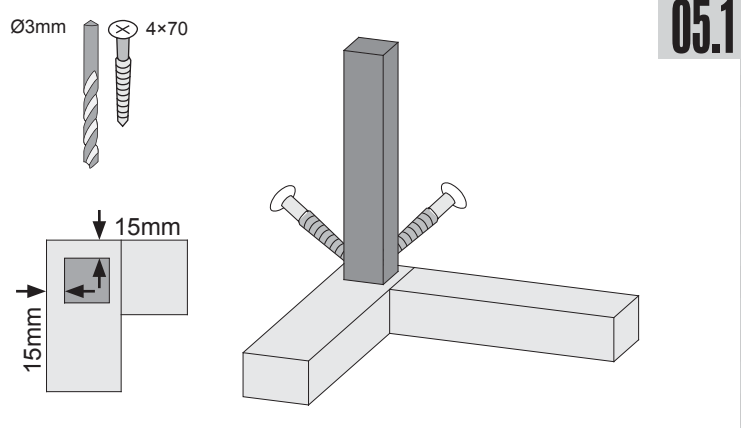
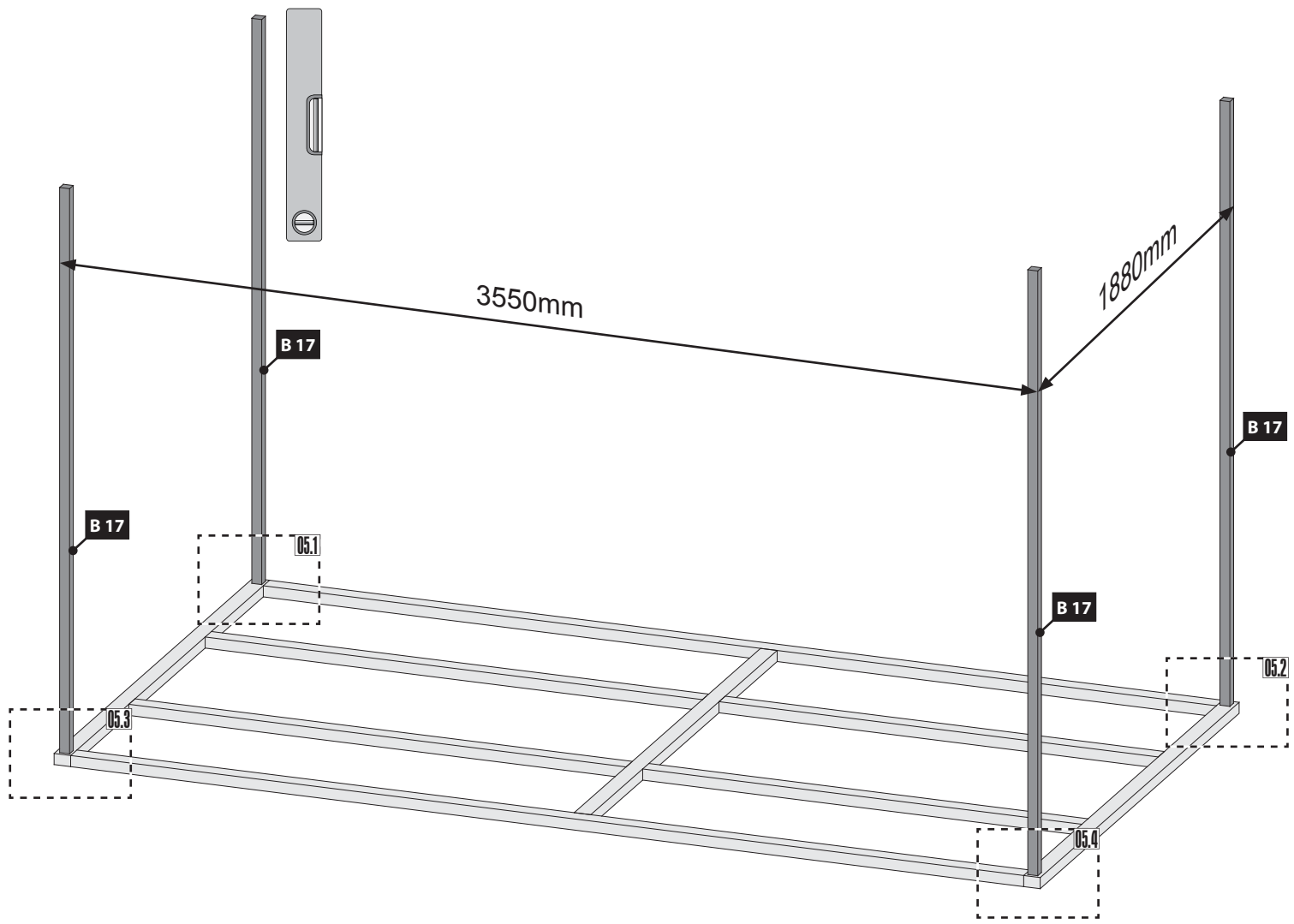

04



-  Draufsicht
-  Top view
-  vue de dessus
-  bovenaanzicht
-  ovenfra
-  vista desde arriba
-  vista dall'alto
-  pŮdorys



 Leim! Achten Sie auf die gleiche Höhe
 Glue! Look for the same height
 Colle! Faites attention à la même hauteur

 Lijm! Besteed aandacht aan de dezelfde hoogte
 Pegamento! Prestar atención a la misma altura
 Colla! Prestare attenzione alla stessa altezza

 Klíž! Dávejte pozor na stejnou výšku

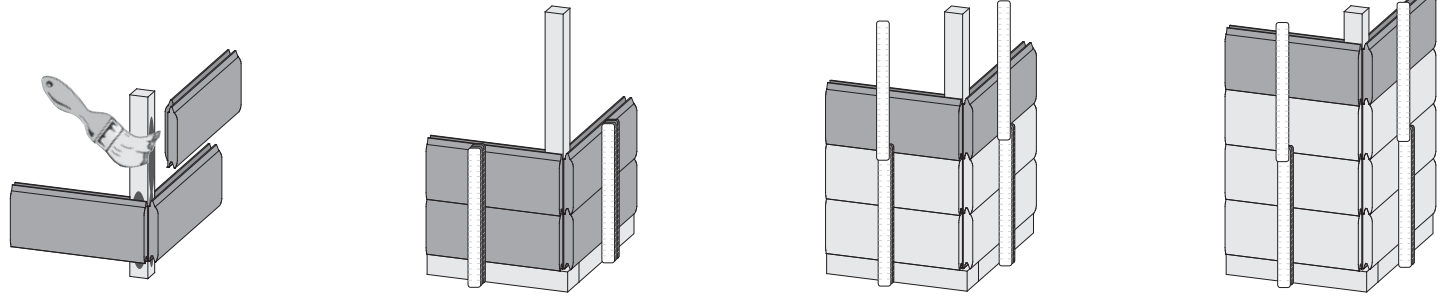

06

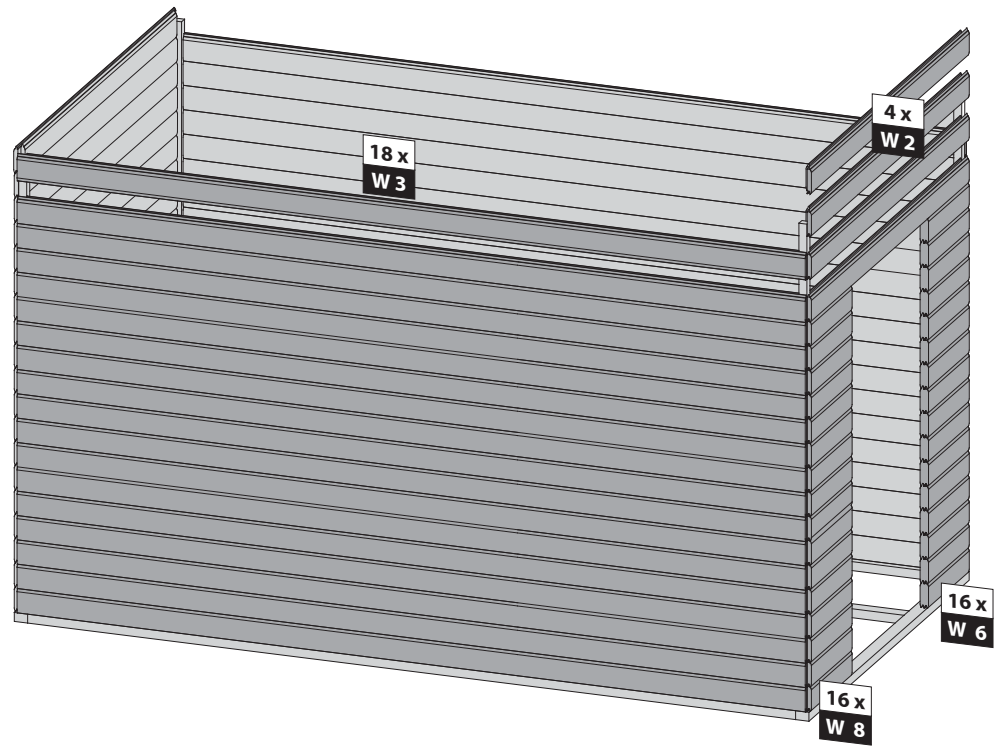
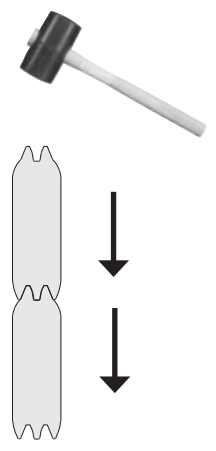
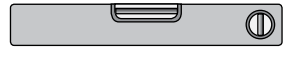
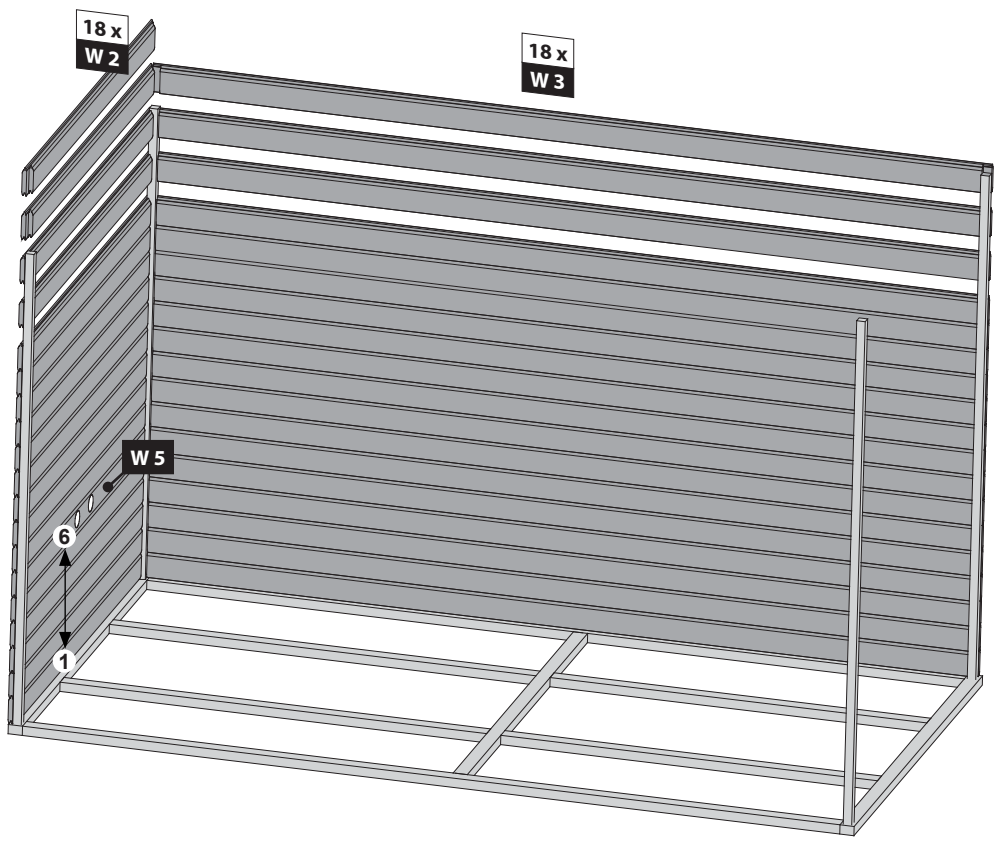

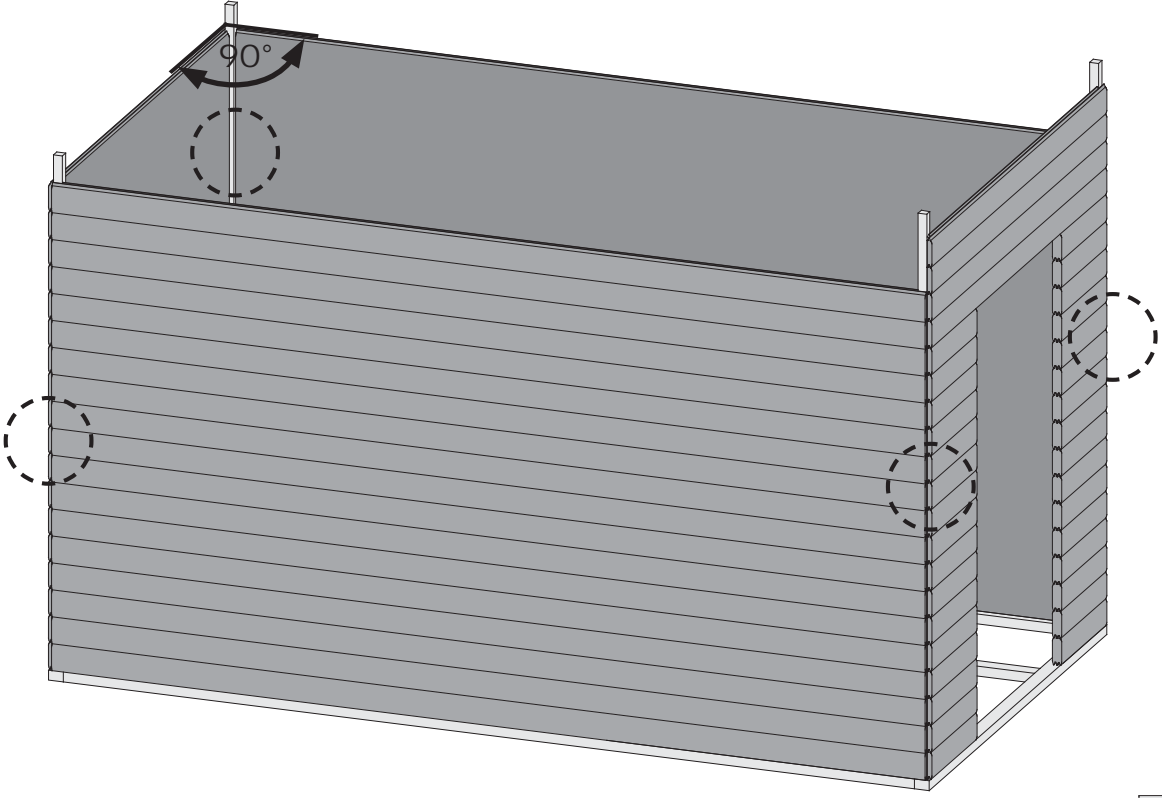

Ø5mm
6x90

Ø3mm
4x40

6x90

4x40

4x40

6x90

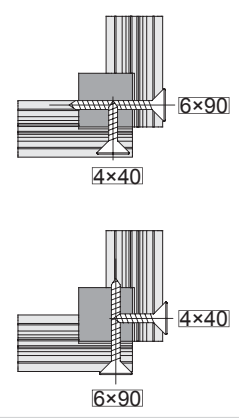
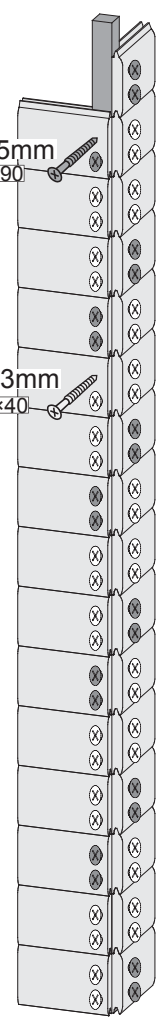

Ø3mm 4x40

Ø5mm 6x90

204x

96x

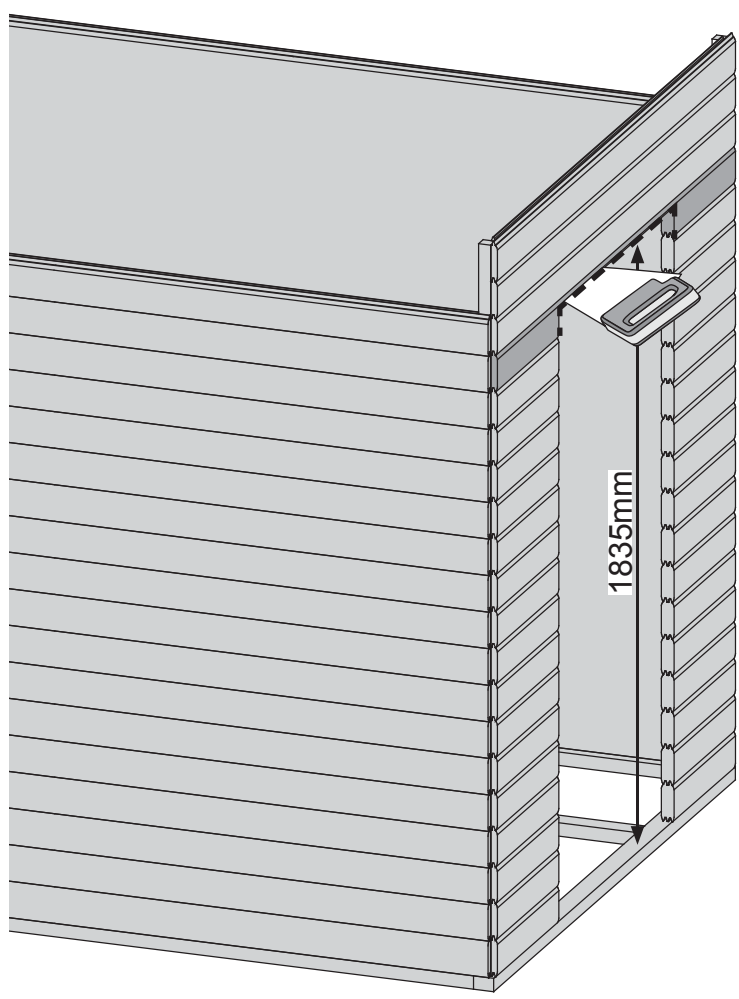
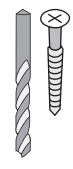

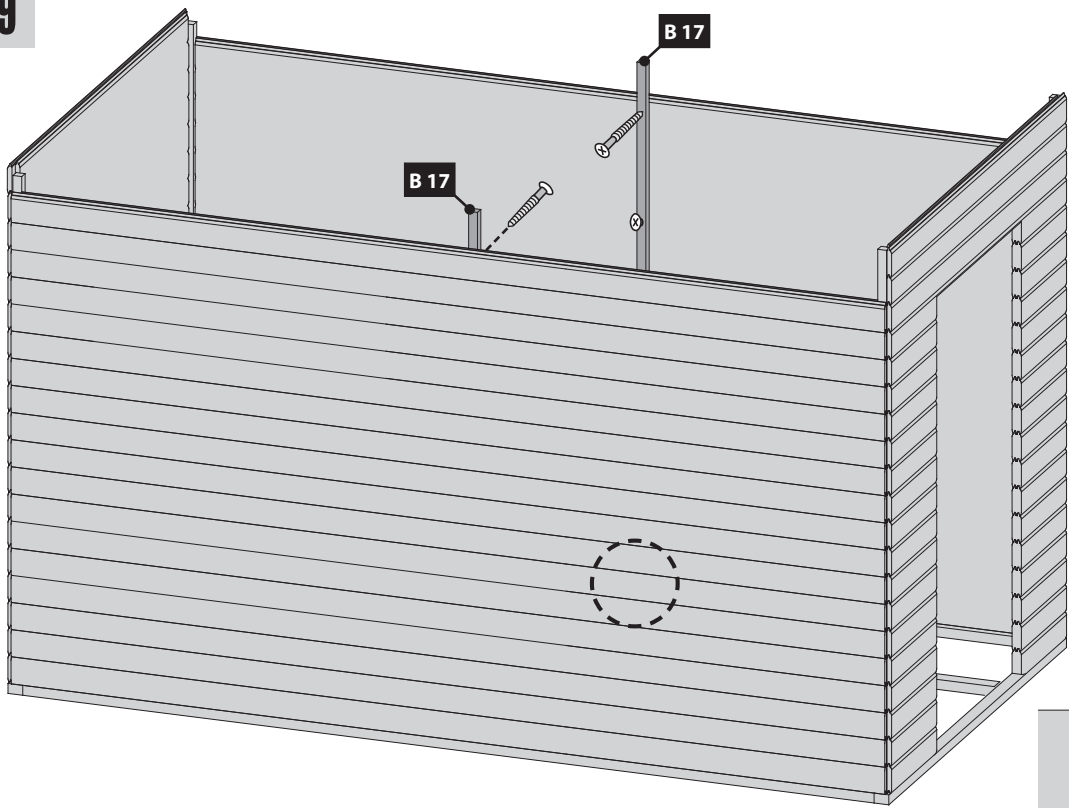

Ø3mm 4×60
10x

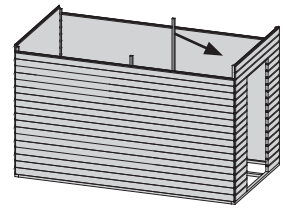
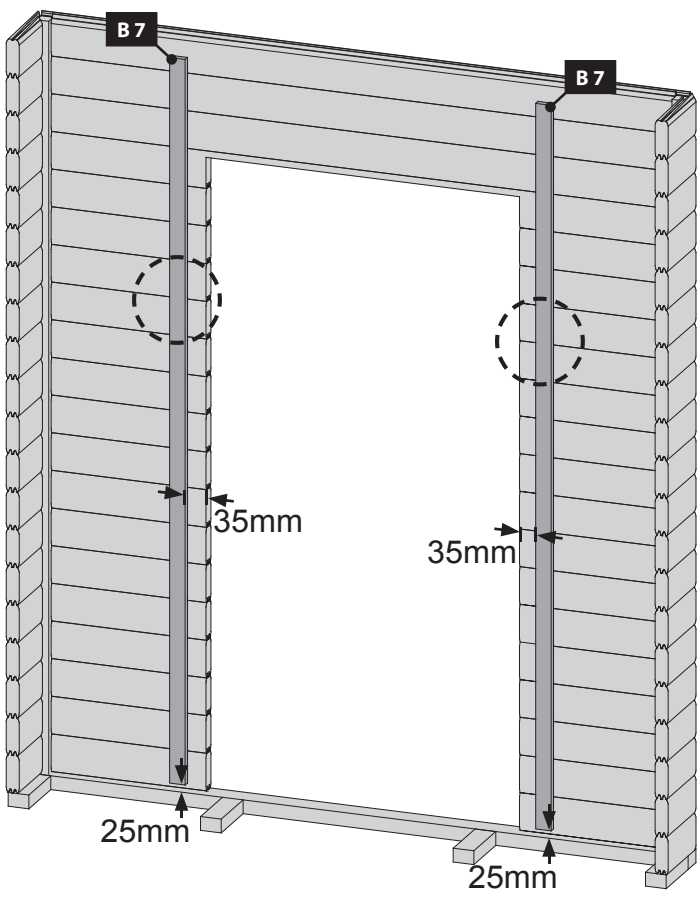
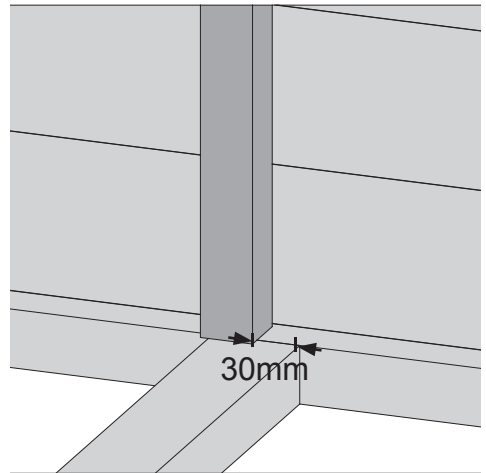

Ø3mm 4×35
76x

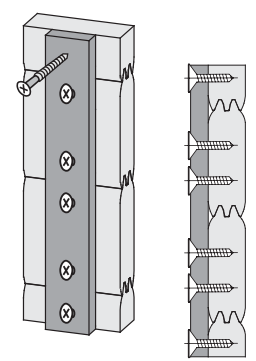

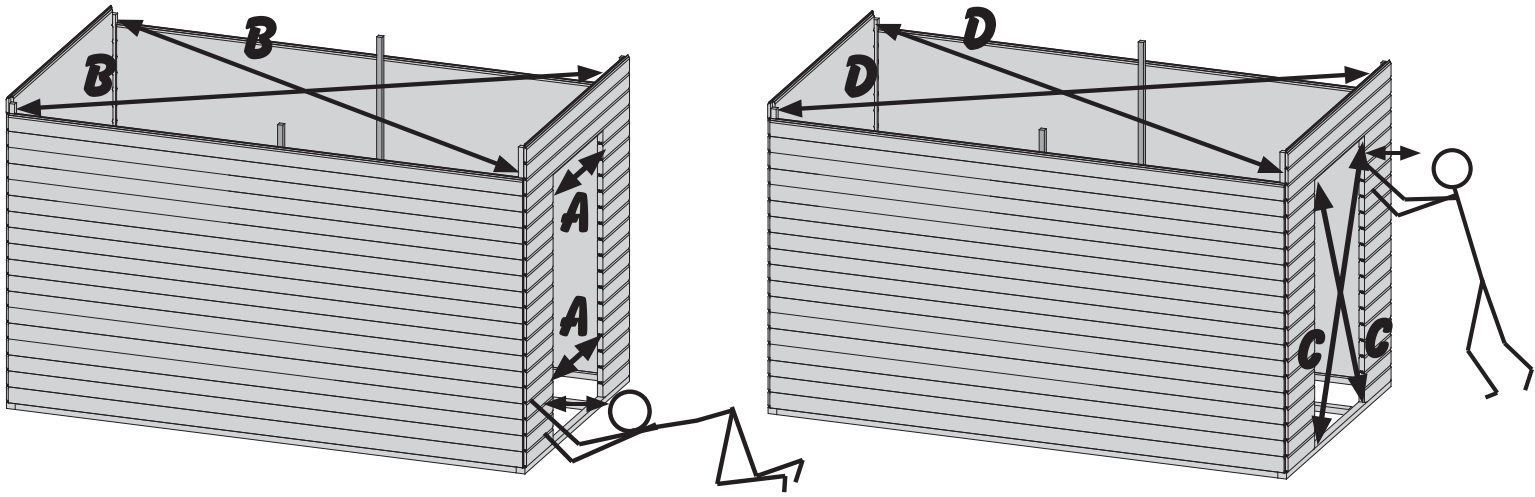

Ø3mm 4x40
77x

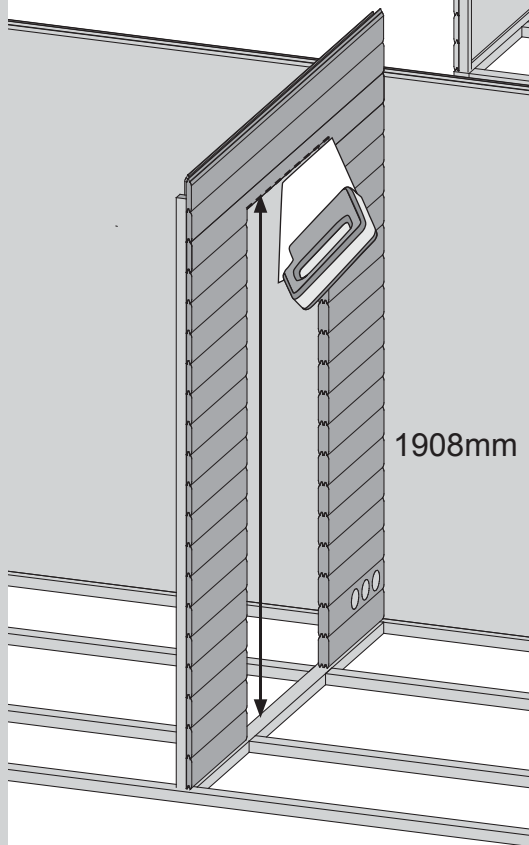
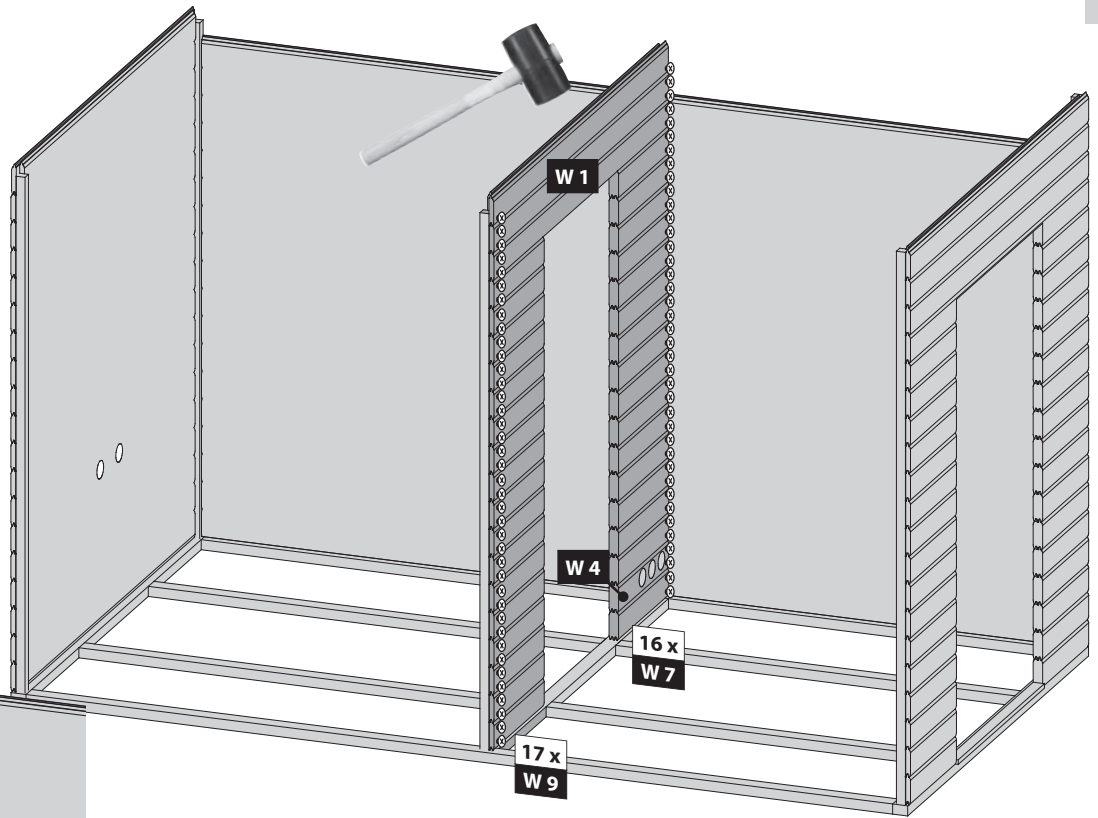

13

320x

-  Bündig!
-  Flush!
-  Affleurement!
-  Gelijk!
-  I flugt!
-  Aras!
-  Combacia!
-  Stejný!

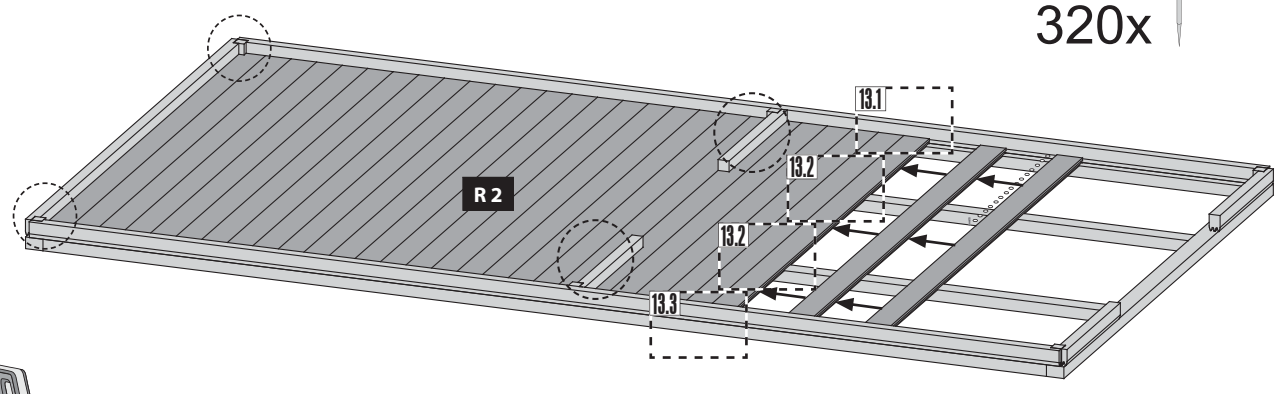
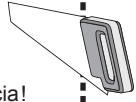

13.1

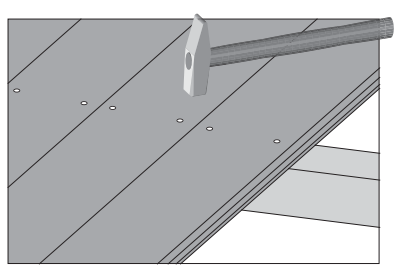

13.2

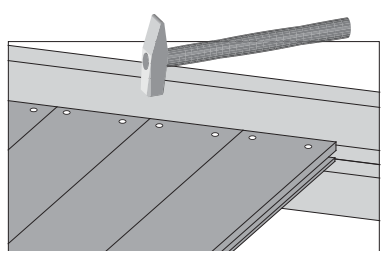

13.3

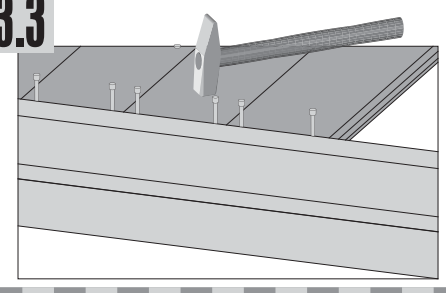

14

-  Bündig!
-  Flush!
-  Affleurement!
-  Gelijk!
-  I flugt!
-  Aras!
-  Combacia!
-  Stejný!

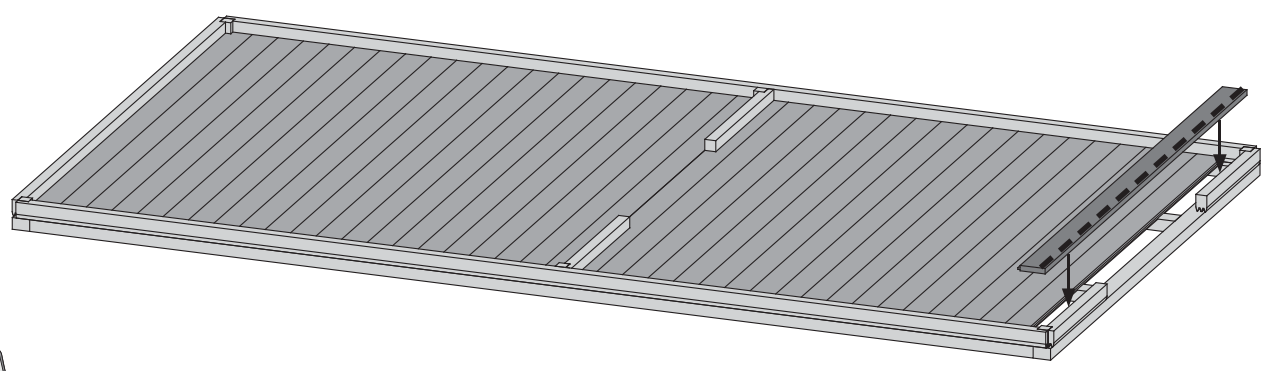
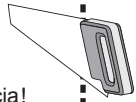

15

Ø3mm 4x50

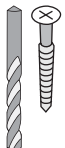

15x

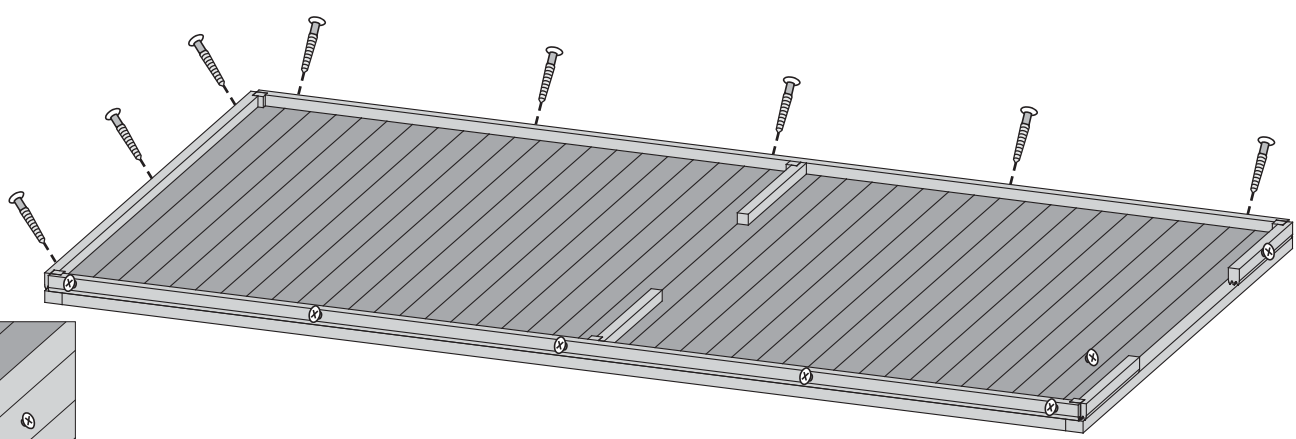
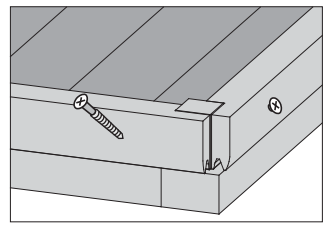

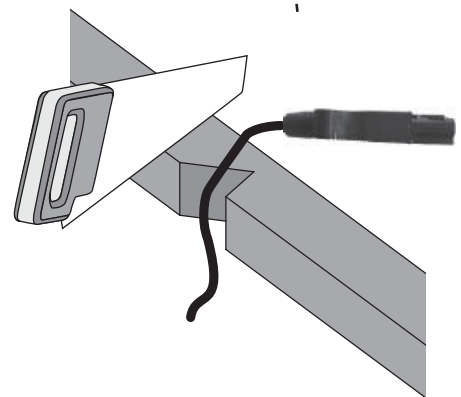
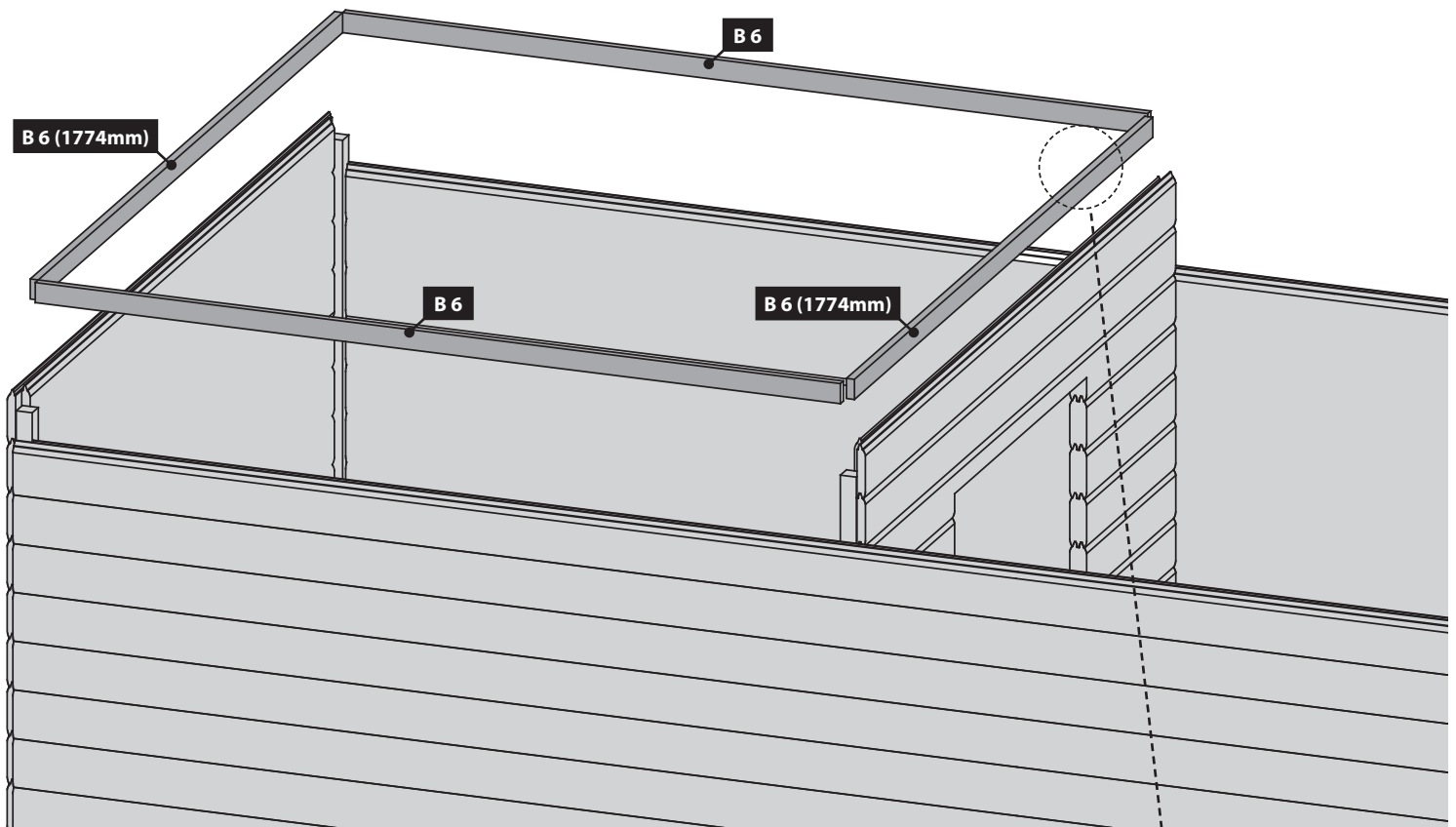
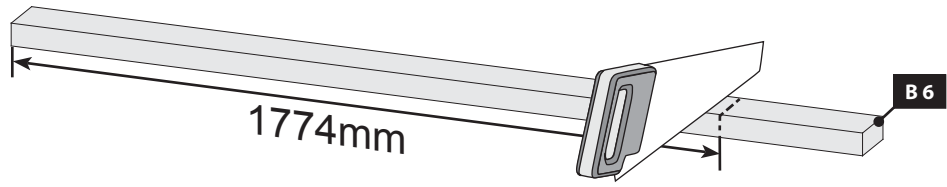

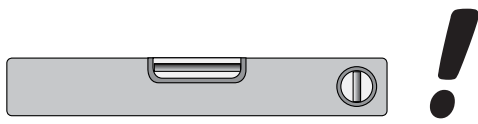
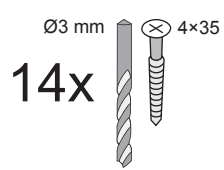
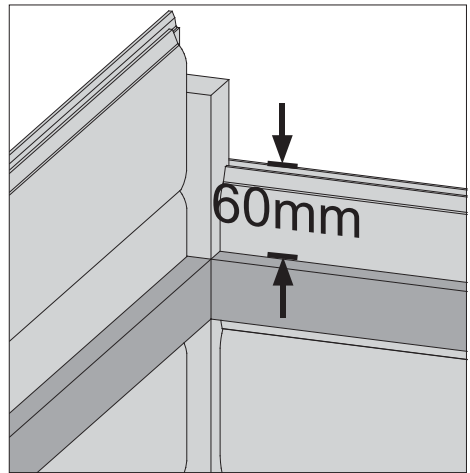
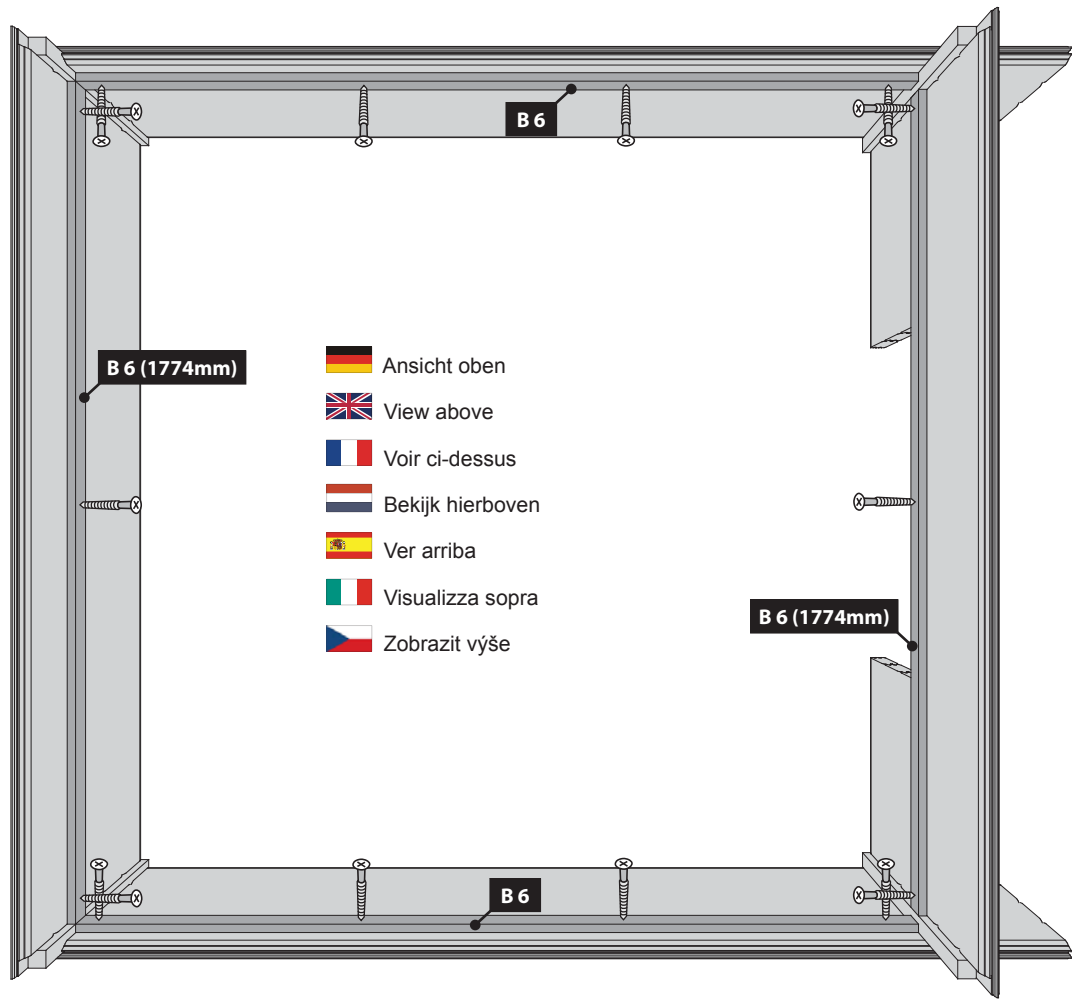

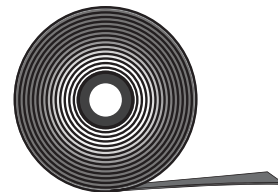
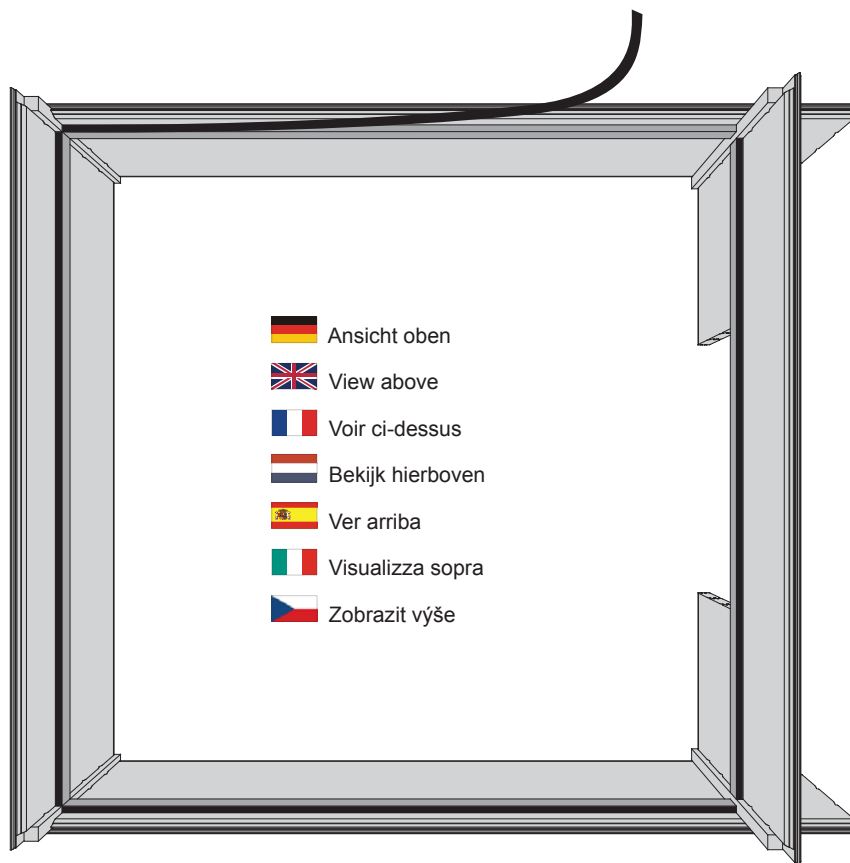



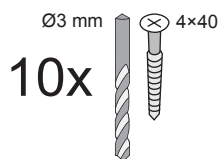



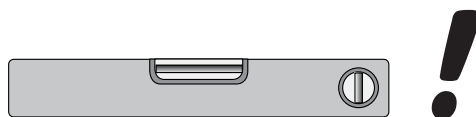
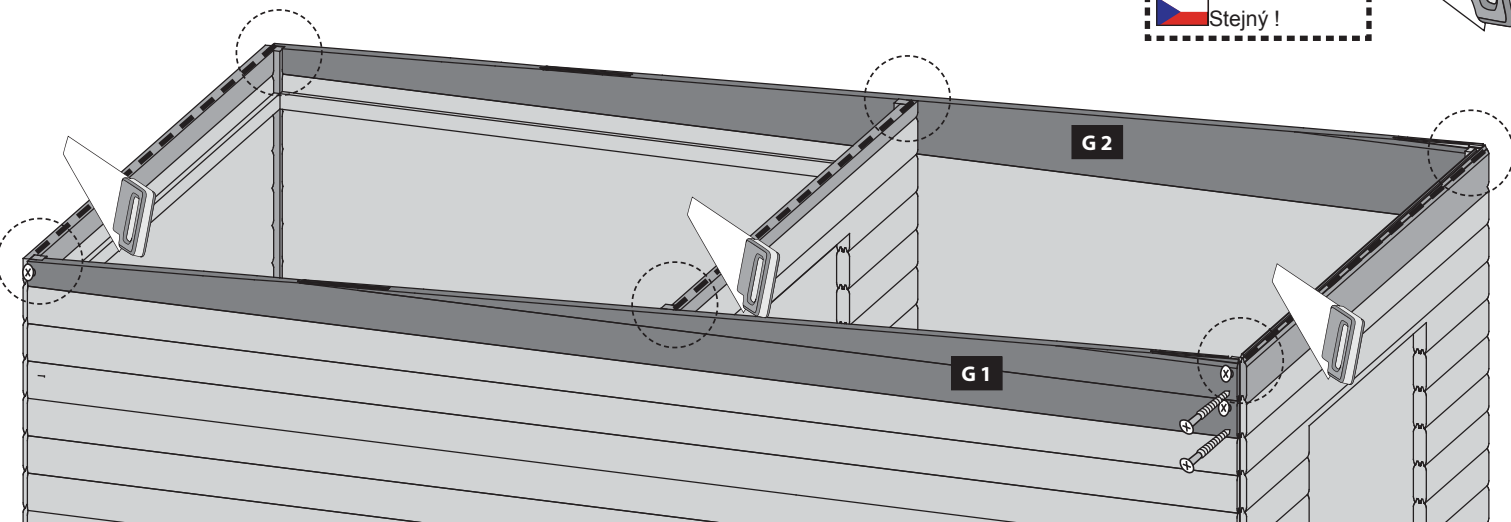
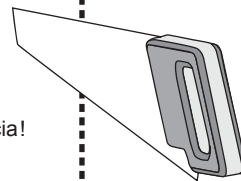

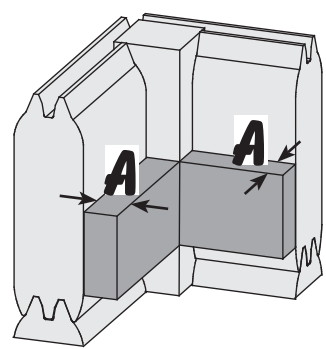
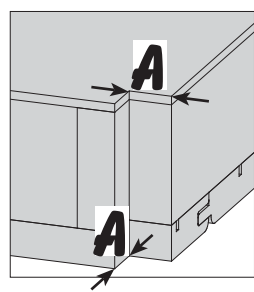
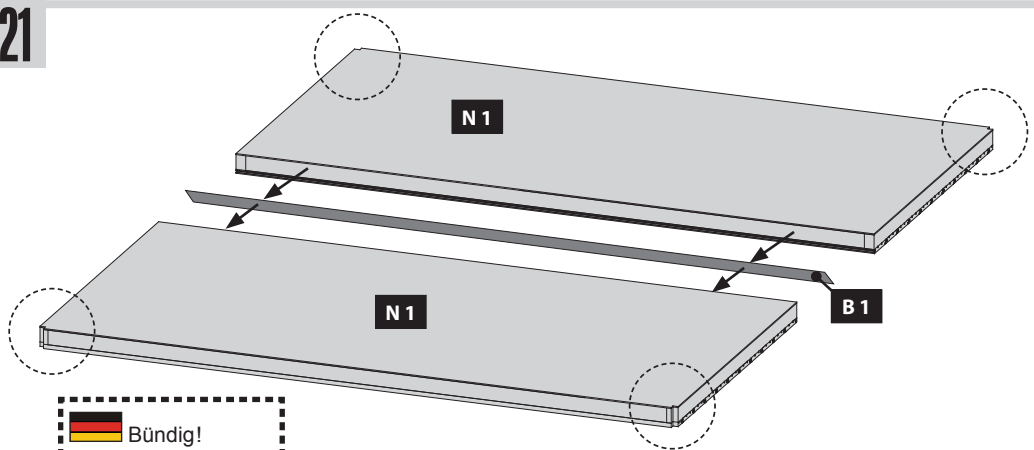
-  Ansicht oben
-  View above
-  Voir ci-dessus
-  Bekijk hierboven
-  Ver arriba
-  Visualizza sopra
-  Zobrazit výše



-  Bündig!
-  Flush!
-  Affleurement!
-  Gelijk!
-  I flugt!
-  Aras!
-  Combacia!
-  Stejný !





-  Bündig!
-  Flush!
-  Affleurement!
-  Gelijk!
-  I flugt!
-  Aras!
-  Combacia!
-  Stejný !

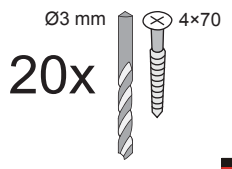
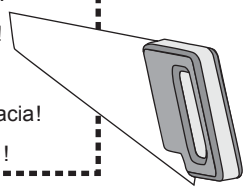

-  Ansicht unten
-  View below
-  Voir ci-dessous
-  Bekijk hieronder
-  Ver debajo
-  Visualizza sotto
-  Zobrazit níže

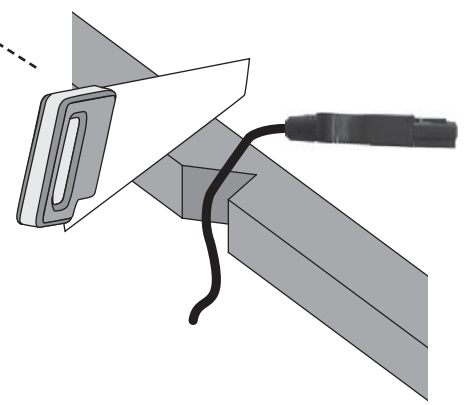
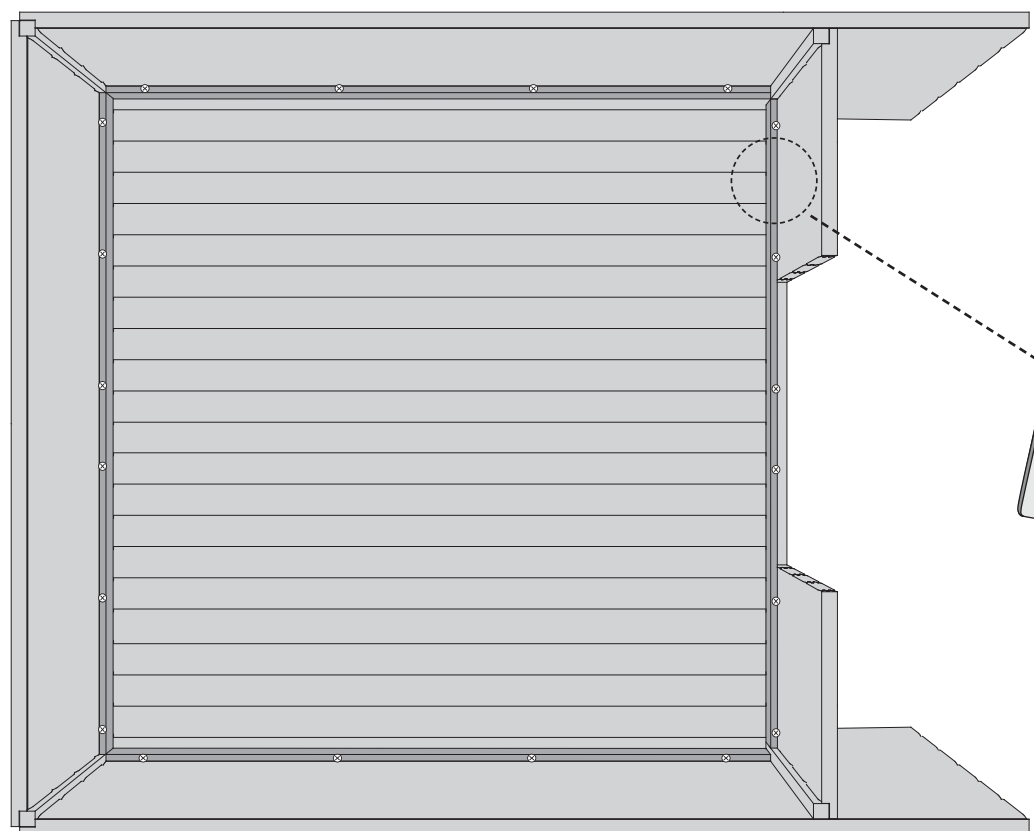
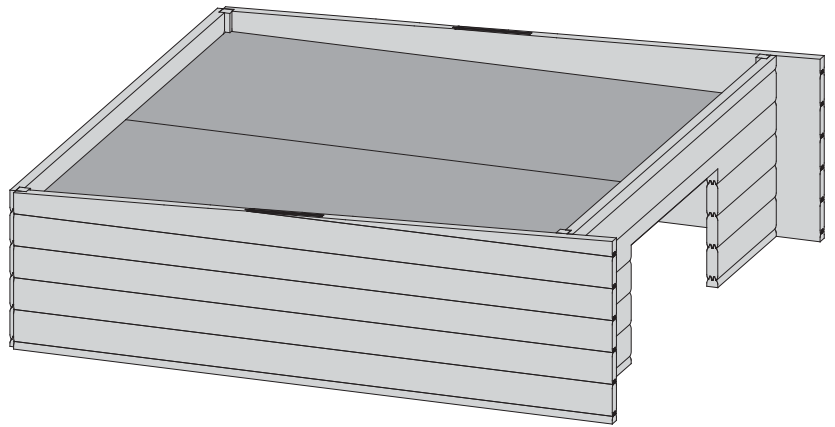

2x

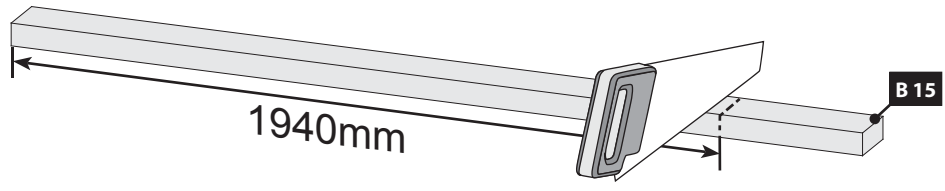

23

1x

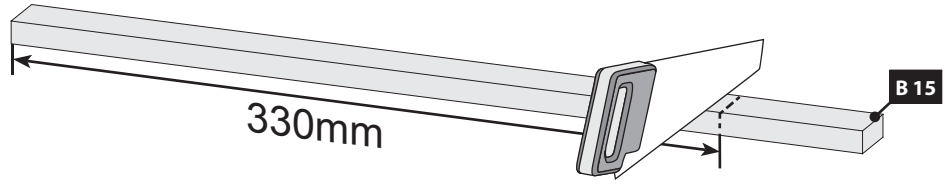

24

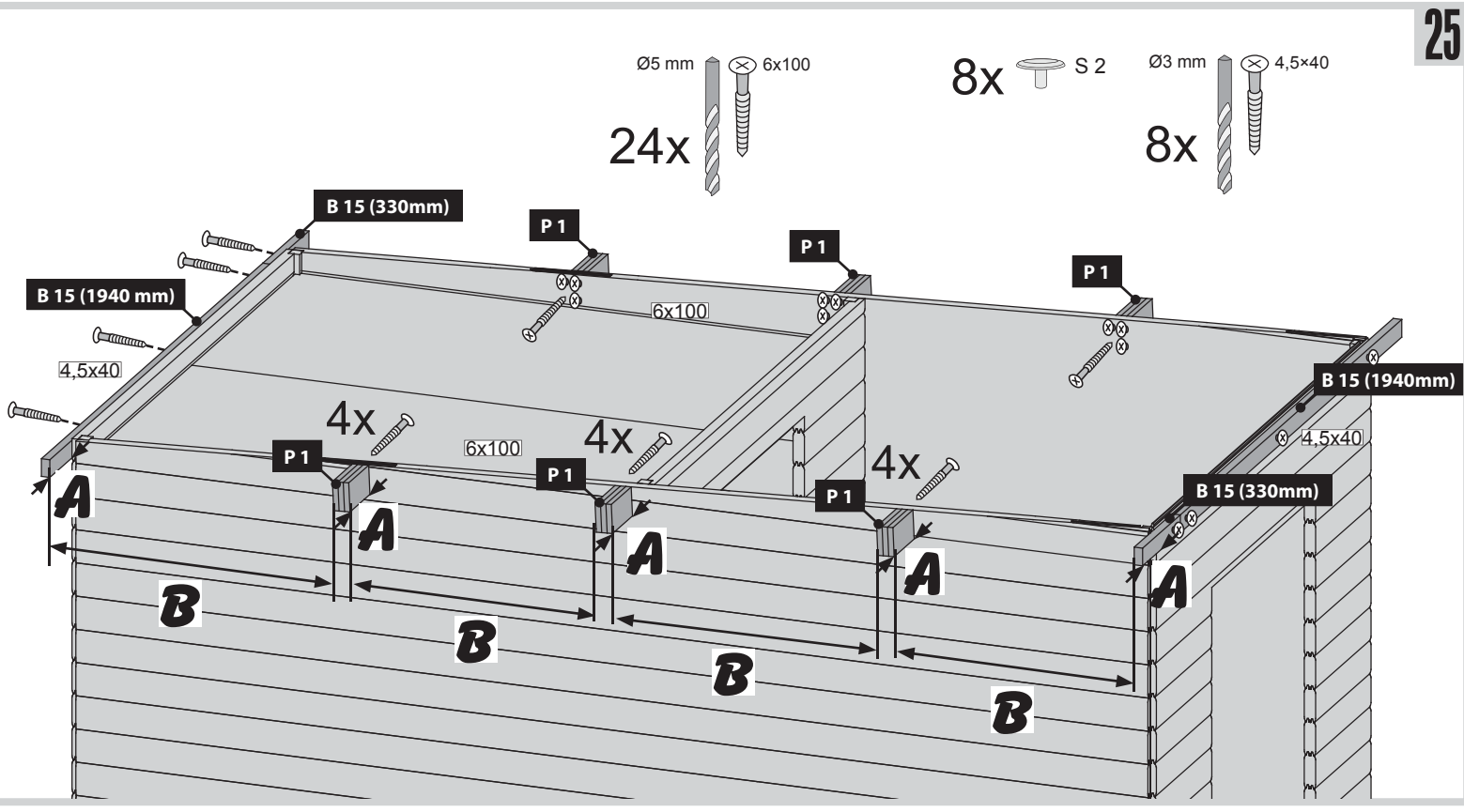

25

Ø3 mm 4x35 96x

12x

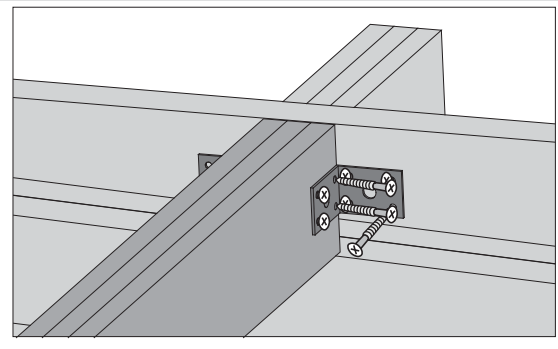

26

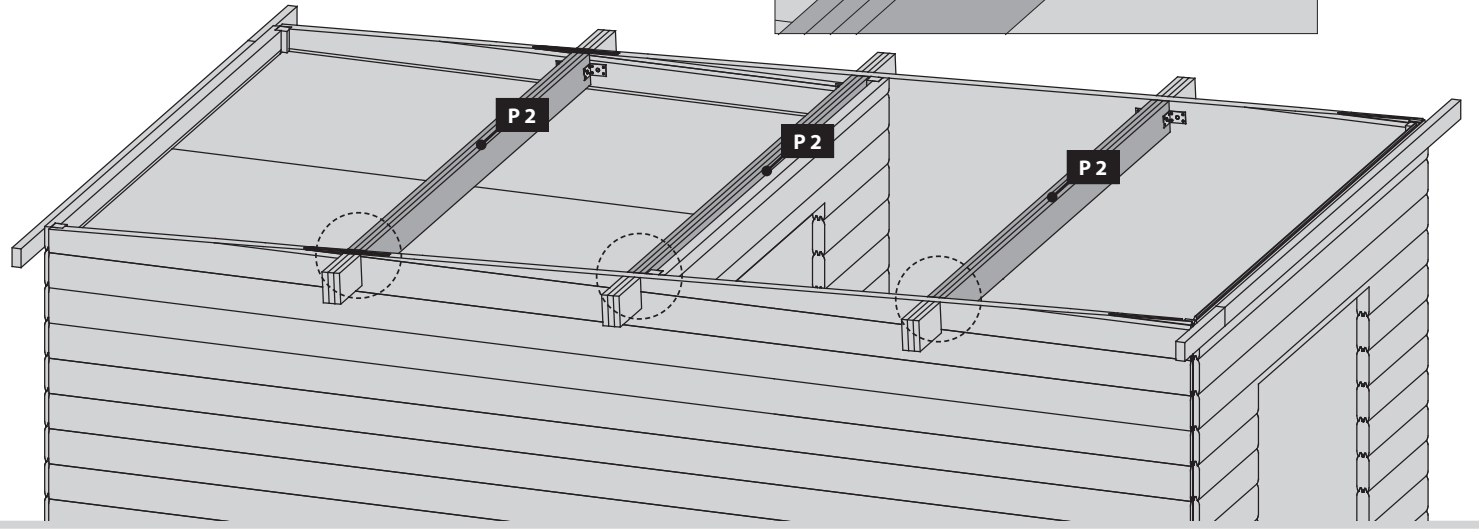

27 2x

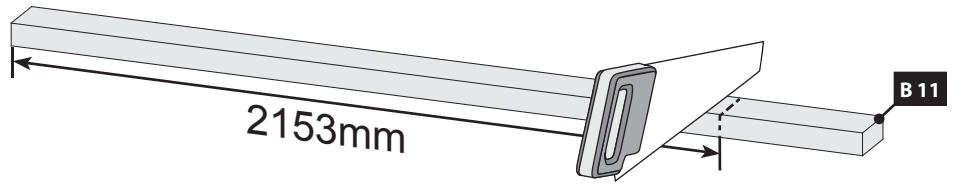

28 2x

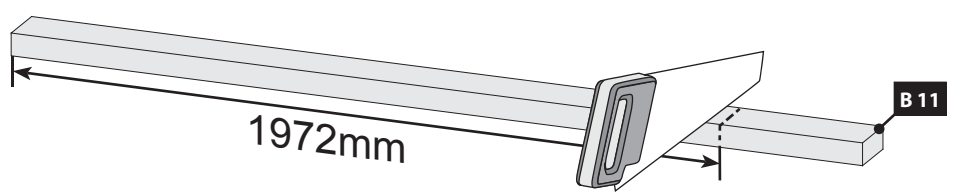

29

40x S 2

Ø3 mm 4,5x40

40x

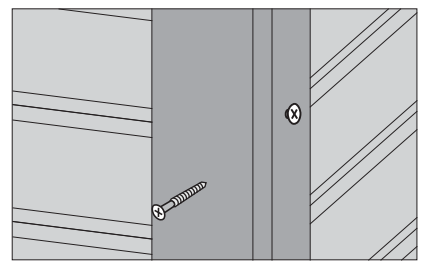
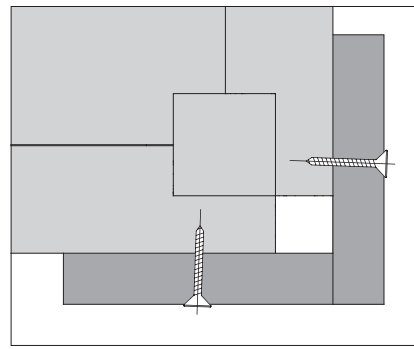
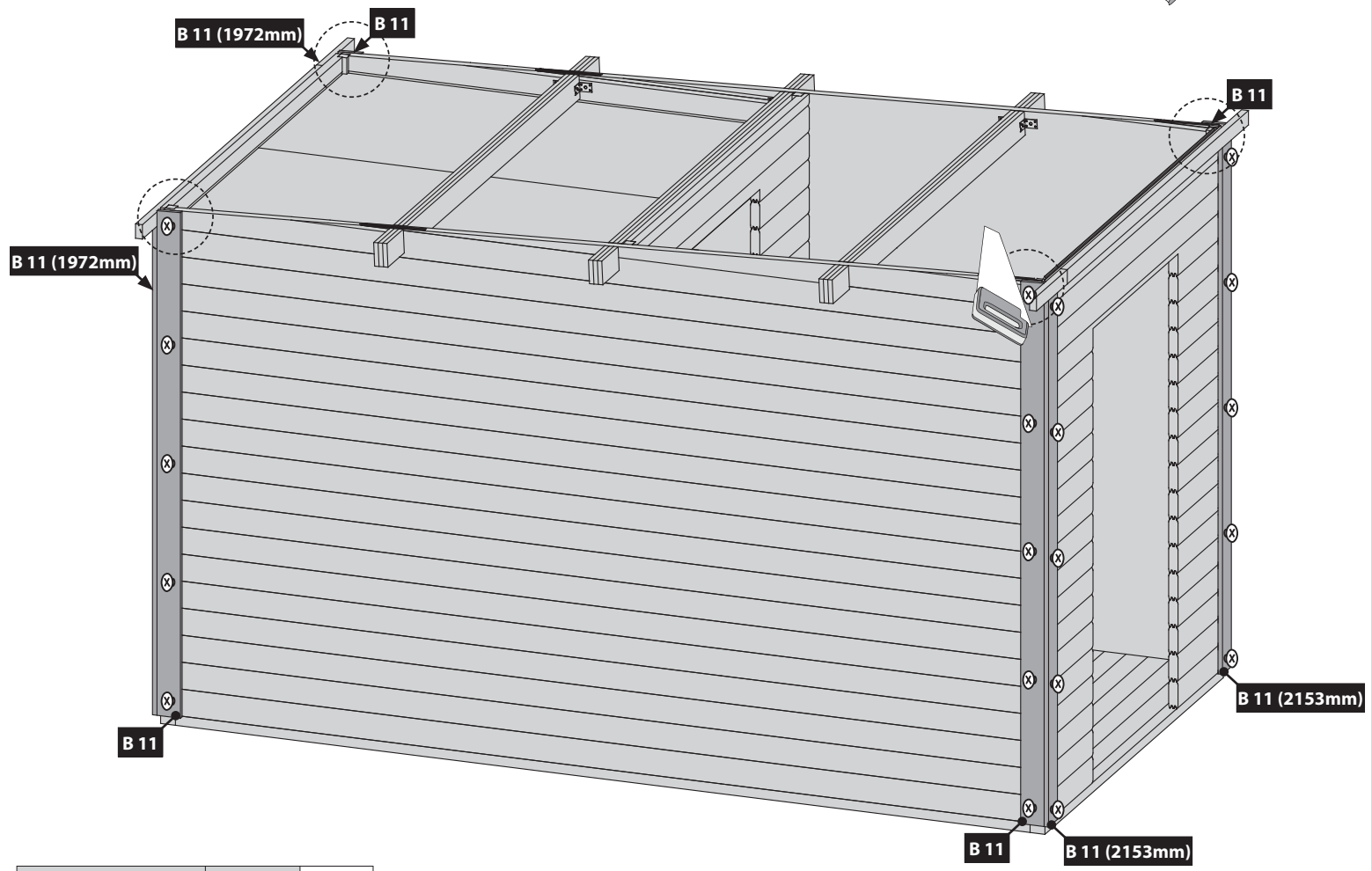

-  Bündig!
-  Flush!
-  Affleurement!
-  Gelijk!
-  I flugt!
-  Aras!
-  Combacia!
-  Stejný!

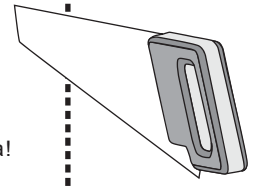

2x

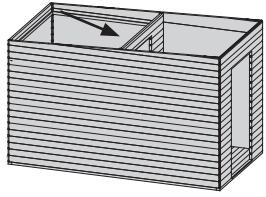
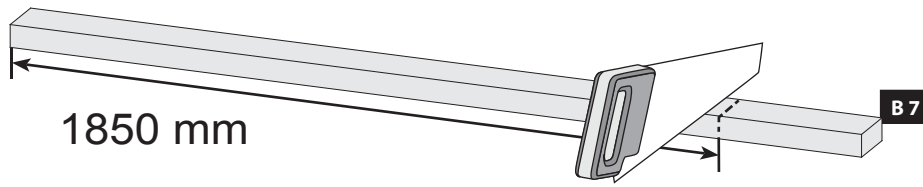

Ø3 mm 4x35

68x

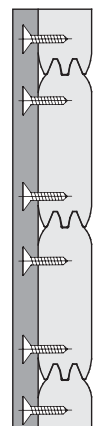
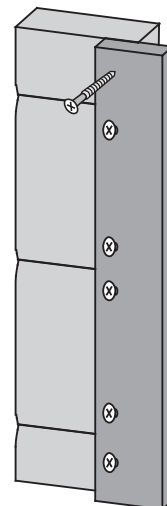
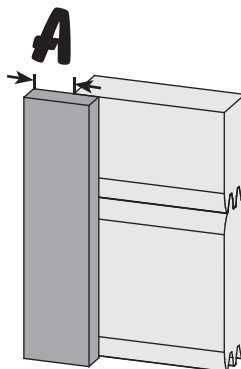
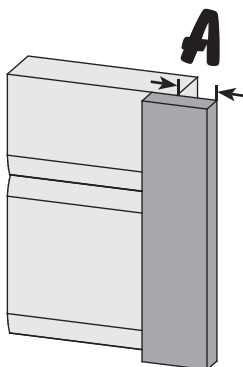
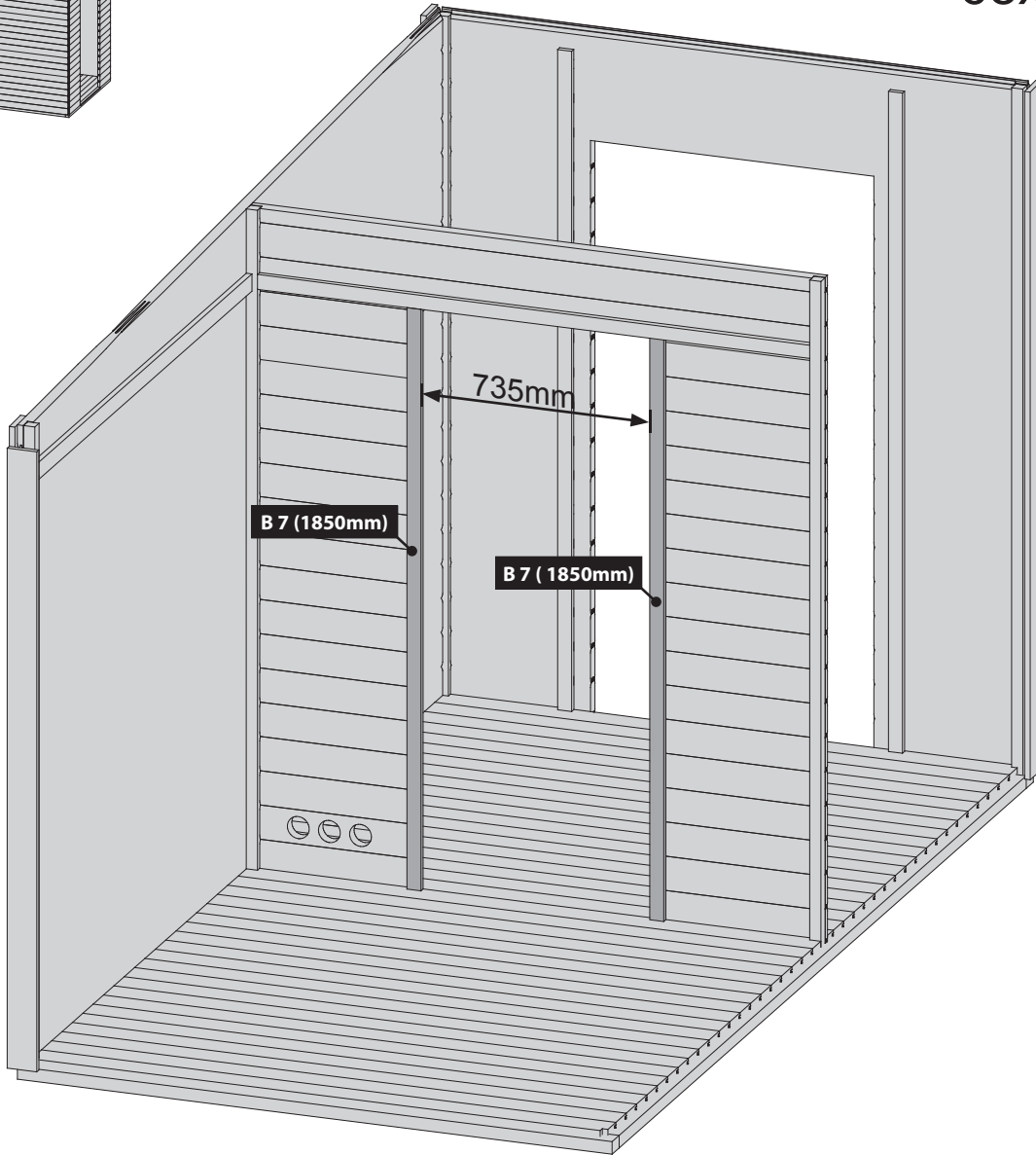

32 2x

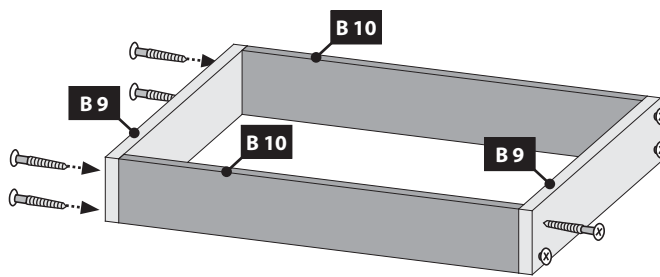

Ø3 mm 4x35
16x

32 a

- Nur bei 9 kW-Ofen
- Seulement 9 kW chauffe
- Only 9 kW heater
- Slechts 9 kW heater
- Sólo calentador de 9 kW
- Solo riscaldamento 9 kW
- Pouze topné těleso 9 kW

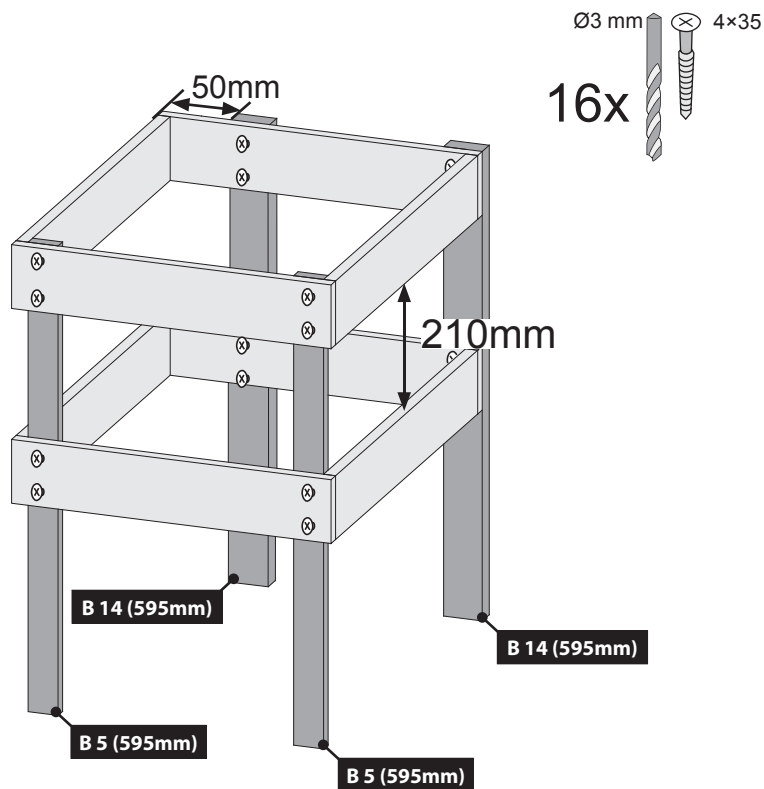
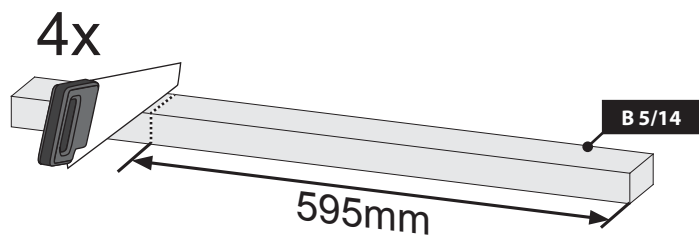

32 b

- Bei allen anderen Öfen
- Pour tous les autres fours
- For all other furnaces
- Voor alle andere ovens
- Para todos los otros hornos
- Per tutti gli altri tipi di forni
- U všech ostatních pecích

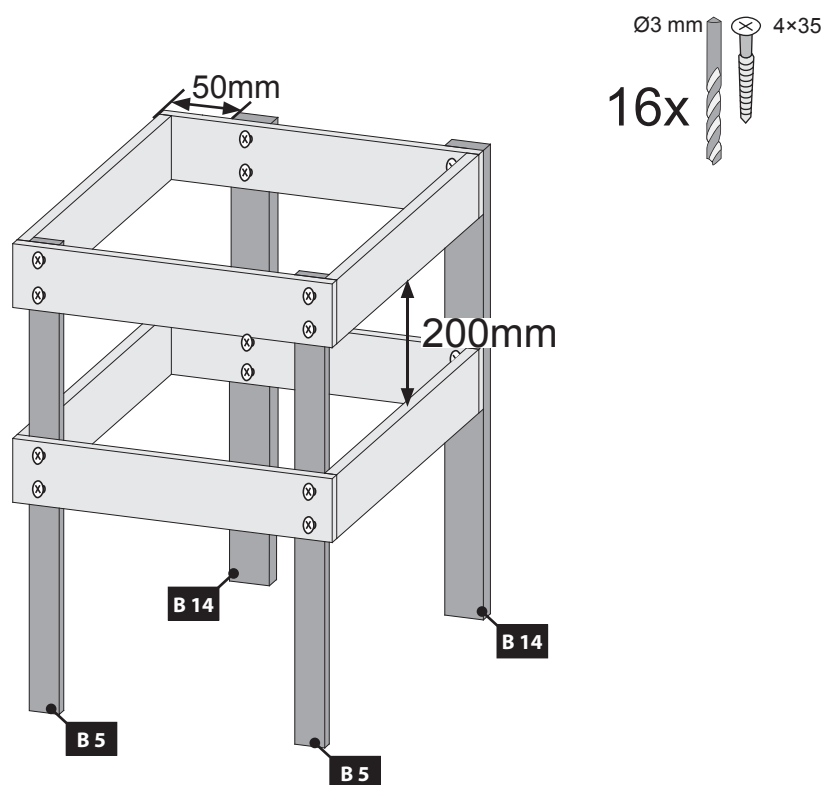

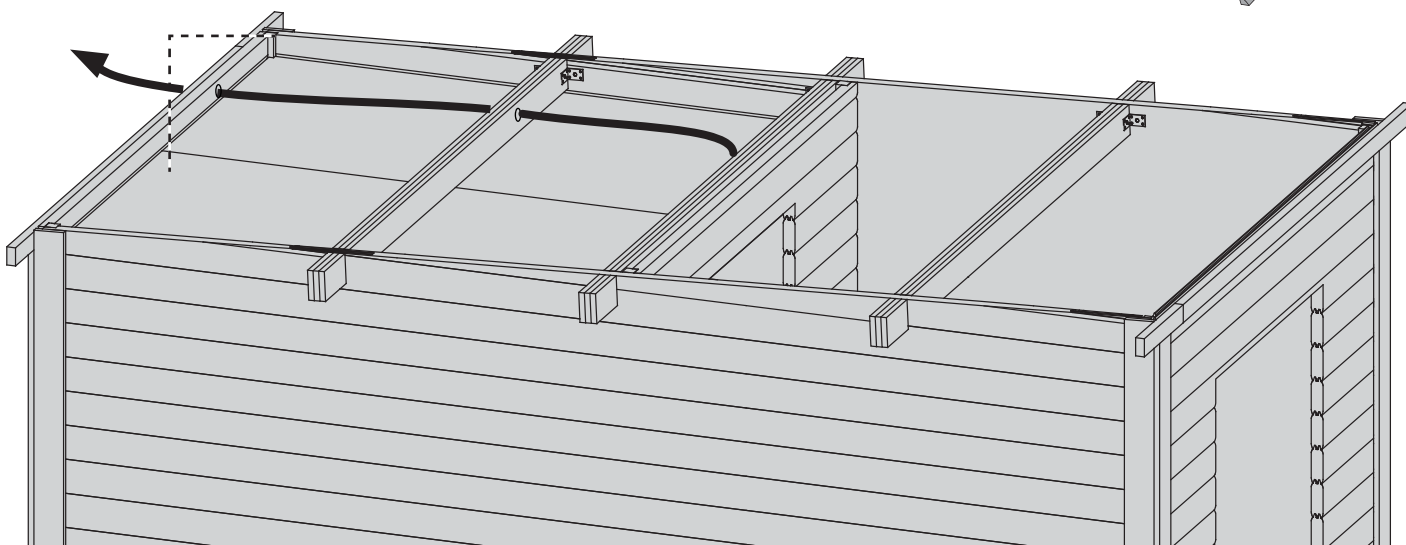
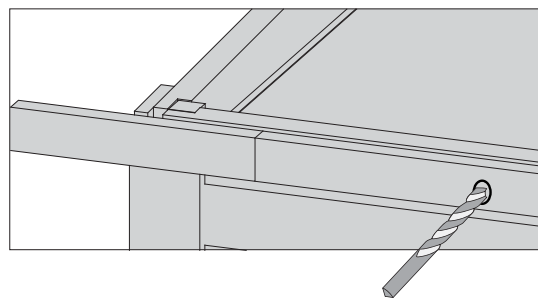
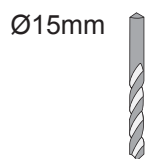
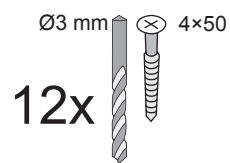
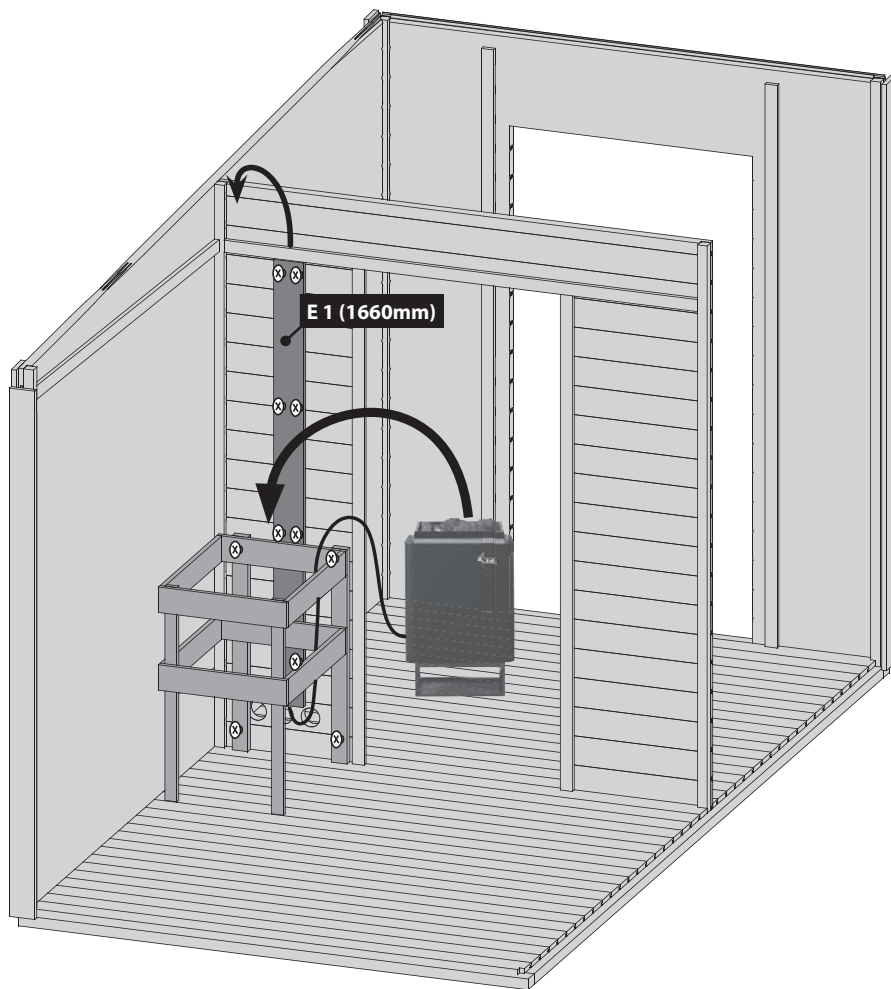
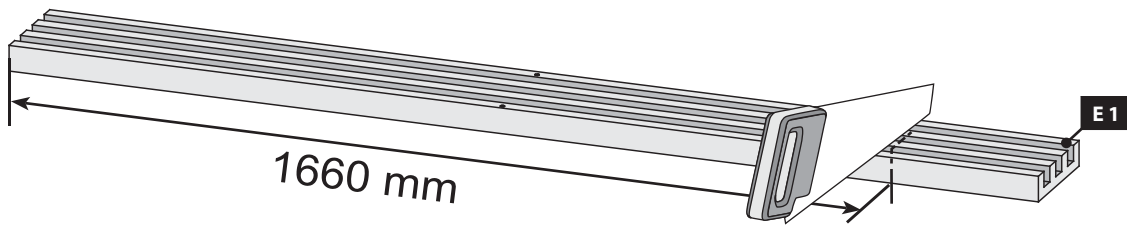

Narrow vers le haut
 Smalle kant naar boven
 Estrecha hacia arriba
 Schmale Seite nach oben
 Stretta verso l'alto
 Úzká stranou nahoru
 Narrow side up

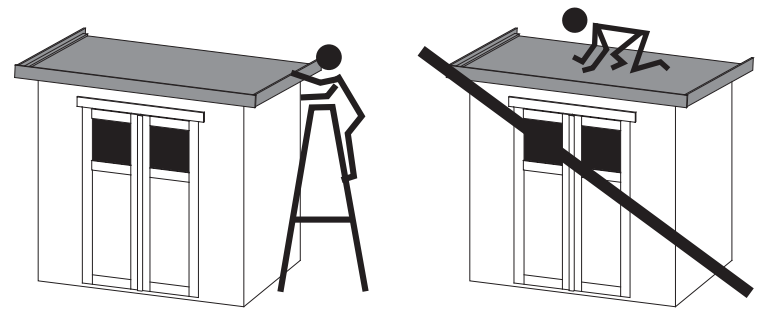

ca 260 x

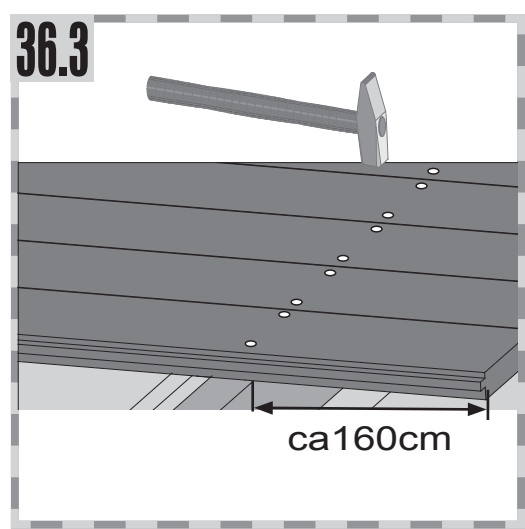
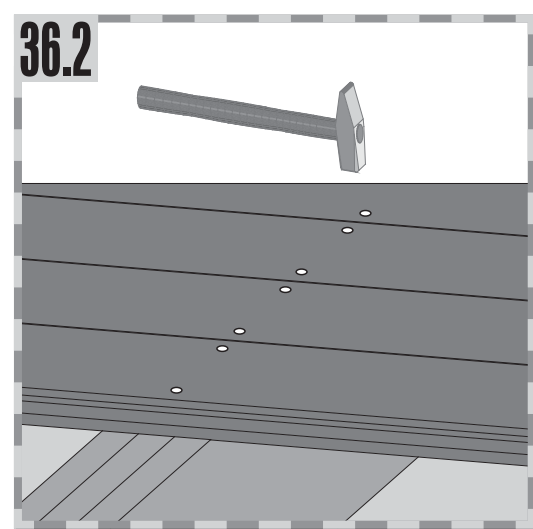
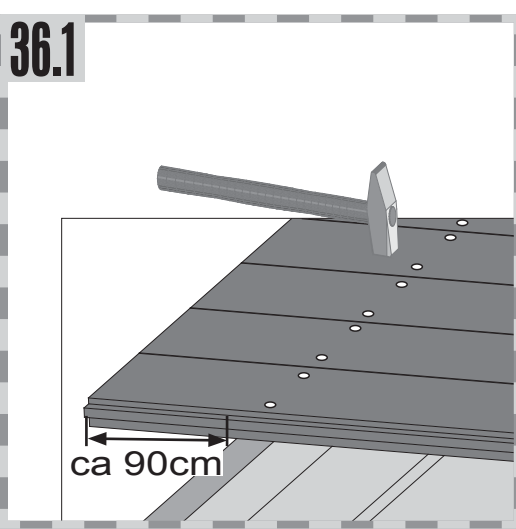
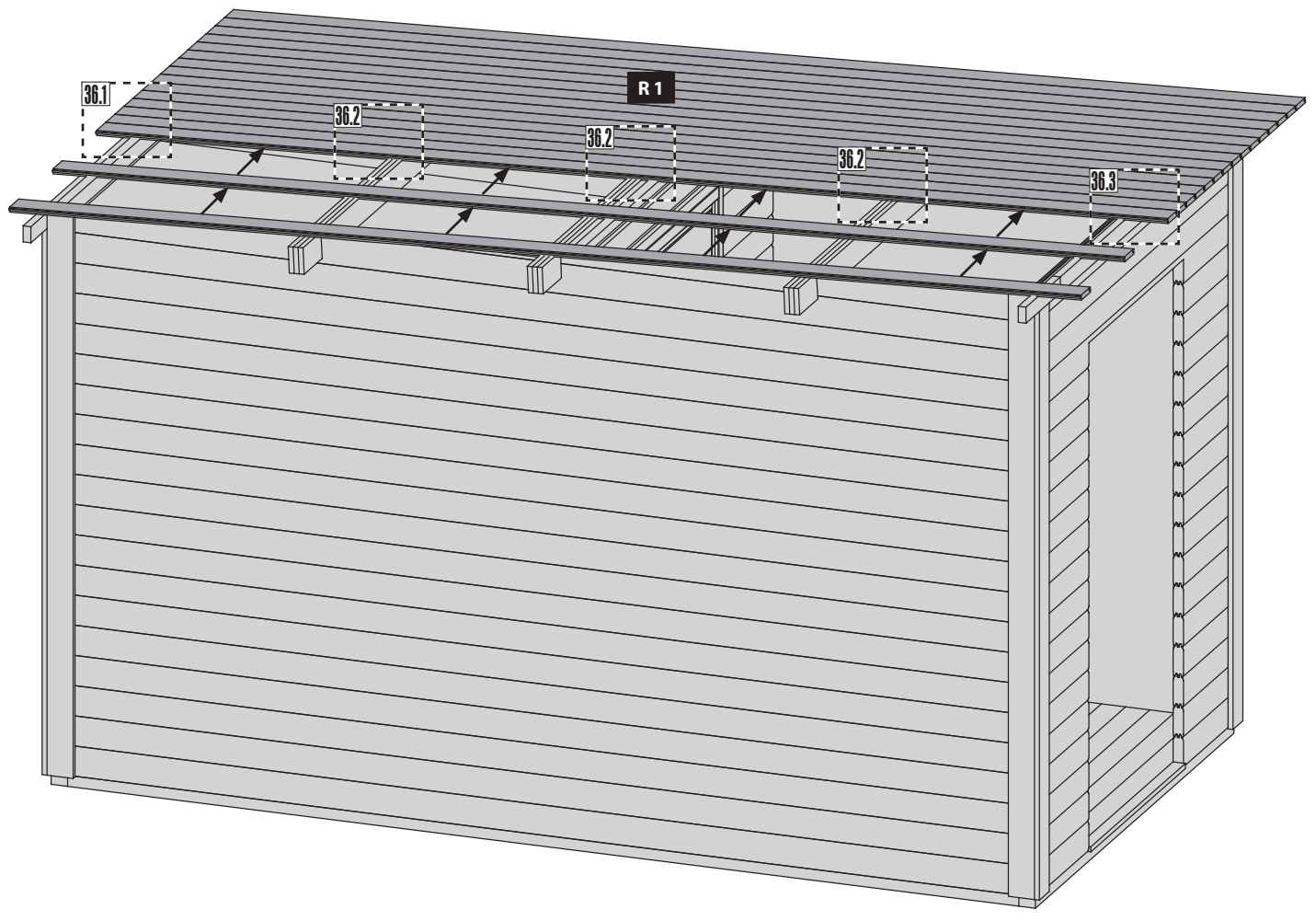

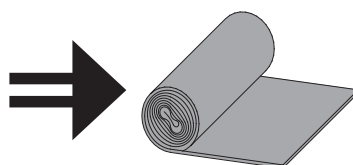
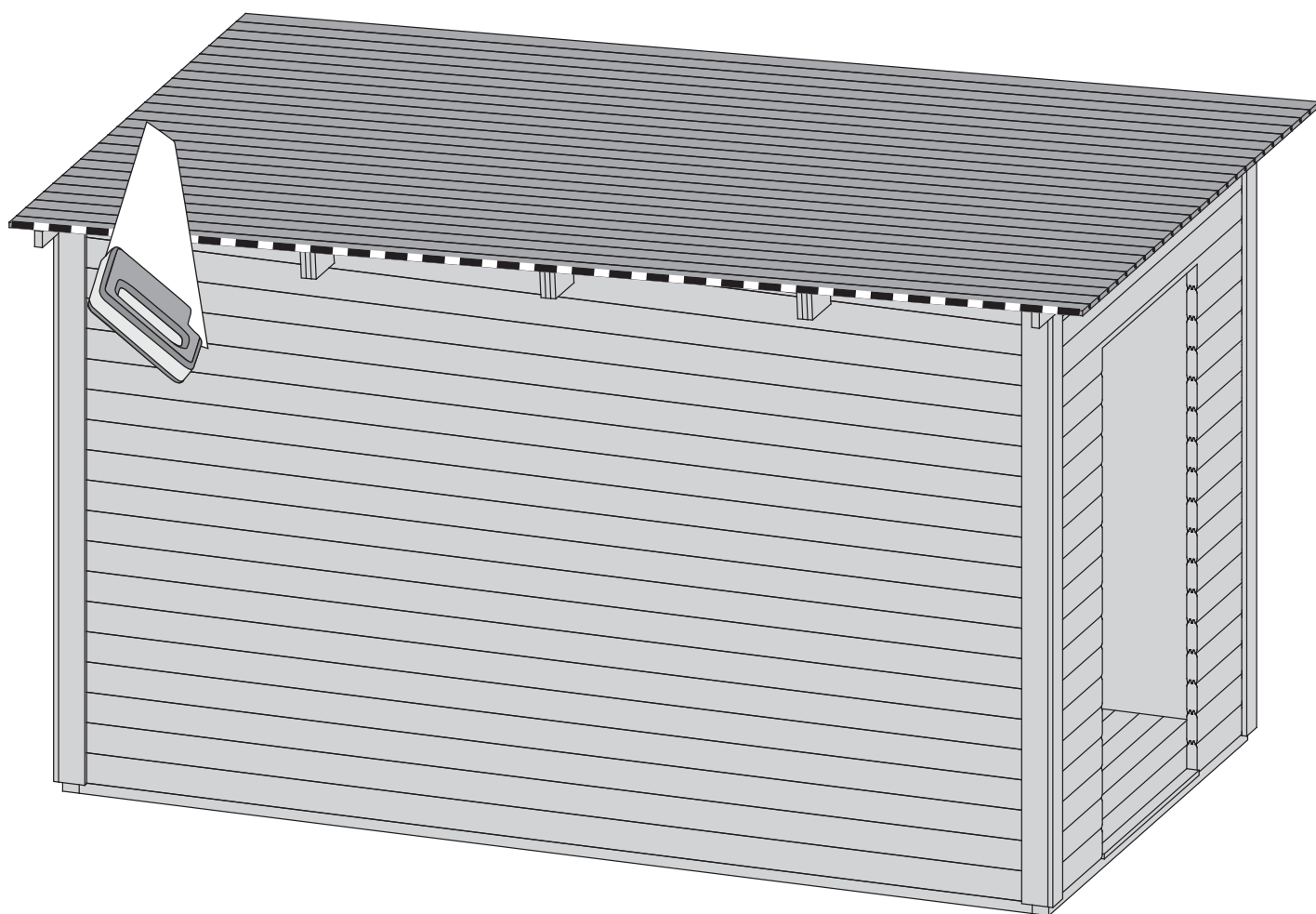
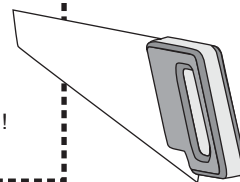

 Montage Bitumendachbelag

 Montage de toiture en bitume

 Montage bitumen underpap

 Copertura bituminosa

 Roofing felt installation

 Montage dakvilt

 Montaje de tela asfáltica

 montáž střešní krytiny

Achtung, dies ist nur ein Verlegebeispiel!

Der mitgelieferte Bitumendachbelag dient zur Ersteindeckung und sollte nach 2 Monaten durch ein eigenes Produkt ergänzt werden. Die Anzahl der Bahnen richten sich nach Ihrer Hausgröße. Verbindungen zwischen den Bahnen sind mit einer Überlappung von ca. 10 cm auszuführen. Das Dach ist nicht begehbar. Die Konstruktion ist für eine Gesamtbelastung (Schnee, Wind) und nicht für eine Punktbelastung ausgelegt. Zur Montage empfehlen wir eine bauseitige Abstützung des Daches von unten. Die Abdichtung der Dachflächen zu angrenzenden Bauteilen mit Bitumendichtmasse ist bauseits zu lösen! Sofern es sich um ein Haus mit Satteldach handelt, sollte bei der Verwendung von Dachschindeln keine Voreindeckung mit Dachpappe vorgenommen werden. Hier sollte lediglich an den beiden Traufseiten ein 20 cm breiter Streifen mit Überstand angebracht werden. Bei Häusern mit einem Tonnendach, verlegen Sie bitte einen Bitumenbelag unter die Schindeln. Bei einem Flachdach ist die Verlegung von Dachschindeln nicht möglich!

Note! This description is only an example!

The supplied bitumen roofing is used for initial cover and should be supplemented by a separate product according to customers choice after two months. The number of bitumen strips to be used depends on your actual house size. When joining rolls of roofing felt end to end, the overlap must be approximately 10cm. The roof is not safe to walk on. The roof is designed for a total load (snow, wind) and not for a point load. We recommend you to always support the roof from below during installation. The sealing of the roof surfaces to adjacent components with bitumen sealant has to be effected by the customer! If it is a saddle-roofed house, do not use roofing tiles for roofing. In this case, a 20 cm wide strip of bitumen with overhang should be installed on both sides of the eaves. For houses with a tonne roof, please install a bitumen roofing under the shingles. In the case of a flat roof the laying of roof shingles is not possible!

Attention, il s'agit uniquement d'un exemple de pose!

Le revêtement du toit fournie se comprend comme dotation initiale. Il est donc recommandé de le compléter par un produit de votre choix après 2 mois. Le nombre de bandes de bitume utilisés dépend de la dimension de la maison. La jointure des bandes de bitume doit être réalisée avec un chevauchement de 10 cm. Ne pas marcher sur le toit! La construction est appropriée pour une charge totale (neige, vent) et ne pas une charge ponctuelle sur un point précis. Lors du montage, il vous est recommandé de soutenir le toit d'en dessous. L'imperméabilisation des surfaces de toit aux composants adjacents avec un mastic de bitume doit être effectuée par le client! Lorsque vous utilisez des bardeaux pour couvrir une maison avec un toit à deux versants, ne jamais utiliser toiture en bitume ci-dessous. Pour les maisons avec toit en berceau, poser du carton bitumé sous les bardeaux. Pour les maisons de toit plat de la pose de bardeaux de toiture n'est pas possible!

Let op, dit is slechts een montagevoorbeeld!

De geleverde bitumen dakbedekking wordt gebruikt voor initiële en moet worden aangevuld met een afzonderlijke product na 2 maanden. Het aantal dakviltbanen is afhankelijk van de grootte van uw huis. Verbindingen tussen de stroken uit te voeren met een overlapping van ongeveer 10 cm. Het dak is niet beloopbaar. De constructie is ontworpen voor een totaalbelasting (sneeuw, wind) en niet voor een puntbelasting. Voor de montage adviseren we te voorzien in een zelf aan te brengen steun voor het dak van onderen. De afdichting van de dakoppervlakken van aangrenzende componenten met bitumen afdichtmiddel op te lossen door de klant! Als het gaat om huis met een zadeldak, mag geen Voreindeckung worden gemaakt met dakleer in het gebruik van dakbedekking gordelroos. Hier, moet alleen de twee dakrand zijden een 20cm brede strook dakleer aan te leggen met een overstek. Voor huizen met een dak vat installeer dan een dakleer onder de gordelroos. Met een plat dak leggen shingles is niet mogelijk!

Bemærk, dette er kun et monteringseksempel!

Den medleverede inddækning tjener kun til midlertidig inddækning og skal senest efter 2 måneder erstattes med et hertil egnet produkt. Antallet af påkrævede ruller af tagbeklædning afhænger af husets faktiske størrelse. Ved sammenføring af tagdækning ruller ende til ende, skal overlappningen være 10 cm. Når du kun bruger 4 baner af tagpap, skal du altid dække den vandrette kantbjælke med rullerne fra begge sider. Taget er ikke sikkert at gå på. Taget er designet til en total belastning (sne, vind) og ikke for en punktbelastning. Vi anbefaler at du altid støtter taget nedenunder under installationen. Tætningen af tagfladerne til vindbrættet i forenderne skal løses af kunden! Når du bruger tagshingles til at inddække et hus med gav/tag, skal du altid bruge underpap tagbeklædningen. Her lægges et 20 cm bredt bånd af tagbeklædning med overlæg på begge sider. Monter altid underpap tagbeklædningen under tagshingles til huse med et buet tag. Ved fladt tag kan tagshingles ikke anvendes!

Cuidado, éste es sólo un ejemplo de instalación!

La cubierta de bitumen suministrado se utiliza para inicial y debe complementarse con un producto separado después de 2 meses. La cantidad de tiras de tela asfáltica depende del tamaño de su caseta. Las juntas de tela en una tira se realizan solapando la tela asfáltica 10 cm. El techo no es transitable. La construcción está preparada para cargas totales (nieve, viento) y no para cargas puntuales. Para el montaje se recomienda apuntalar el techo por debajo. A menos que haya una casa de techo a dos aguas, sin Voreindeckung debe hacerse con tela asfáltica en el uso de tejas para techos. En este caso, sólo los dos aleros partes deben ser de una amplia franja de 20 cm de tela asfáltica que deben colocarse con un voladizo. Para las casas con el techo abovedado y por favor, instale un techo sintió debajo de las tejas. Con un techo plano por el que las tejas no es posible!

Attenzione, questo è solo un esempio di posa!

La copertura bitume fornito è utilizzato per iniziale e deve essere completato da un prodotto separato dopo 2 mesi. La quantità dei rulli di cartone catramato dipende dalle dimensioni della casa. Il concatenamento tra i nastri deve essere effettuata con una sovrapposizione di circa 10 cm. Non salire sul tetto. La costruzione è progettata per un carico diffuso (neve, vento) e non per una concentrazione puntuale del peso. Per il montaggio si consiglia un supporto del tetto con una costruzione posta sotto di esso. Se si dispone di una casa con un tetto a capanna e si desidera utilizzare tegole di copertura, deve essere posato senza fogli di bitume. Qui, un largo 20 cm striscia di bitume deve essere montato esclusivamente ad entrambi i lati della grondaia sporgente 20 cm. Per le case con fogli di bitume per tetti a botte sotto il fuoco di Sant'Antonio da installare. Si prega di non utilizzare il fuoco di Sant'Antonio Dackdeckung con un tetto piatto.

Pozor, toto je jen příklad, kterým!

Dodaný bitumen se používá pro počáteční a by měl být doplněn samostatný produkt po 2 měsících. Počet Dachpappbahnen závisí na velikosti domu. Spojení mezi asfaltem pásu má být provedena s přesahem asi 10 cm. Při použití pouze čtyři běhy ne Firstbahn použití, boční panely s ležel přes hřeben. Střecha není přístupný. Konstrukce je (sníh, vítr) a není určen pro bodové zatížení na celkové zatížení. Pro montáž doporučujeme znovu podporu na místě střechy zespodu. Utěsnění střešních oblastí do podhledů na čelních plochách je na místě řešit! Máte-li dům se sedlovou střechou, je třeba žádné Asfaltové pásy umístěny pod šindele. Zde je 20 cm široký pás střešní plst' je pouze na obou stranách okapového se supernatantem odloženou. Pro rodinné domy s valenou střechou prosím ležel lepenkový pod šindelem. Pro ploché střechy domů pokládka střešních šindelů není možné!

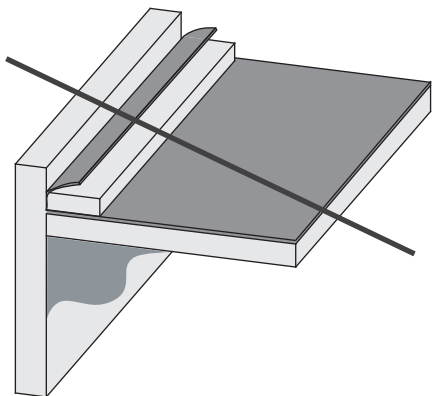
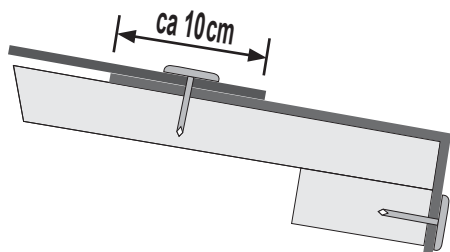
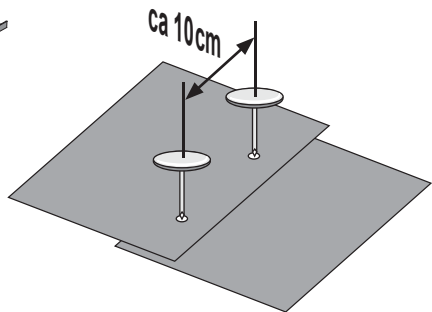
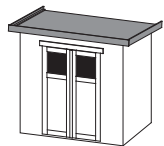



*

 Nicht im Lieferumfang enthalten! Vor Feuchtigkeit schützen!

 Not included! Protect from moisture!

 Non comprises dans la livraison! Protéger de l'humidité!

 Niet bijgeleverd! Beschermen tegen vocht!

 Ikke inkluderet! Beskyt imod fugt!

 No forman parte del suministro! Protegerlo de la humedad!

 Non incluso! Proteggere dall'umidità!

 V ceně není zahrnuto! Chránit před vlhkostí!

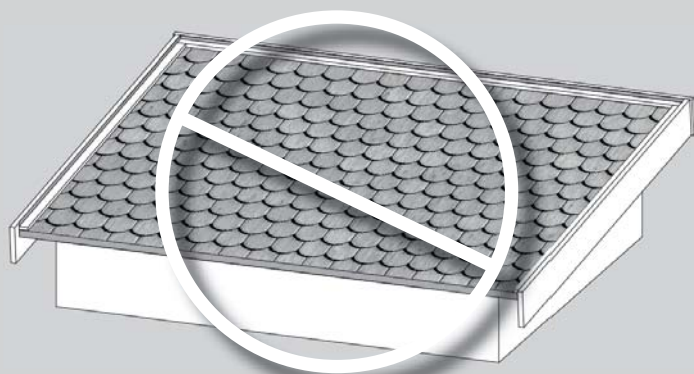
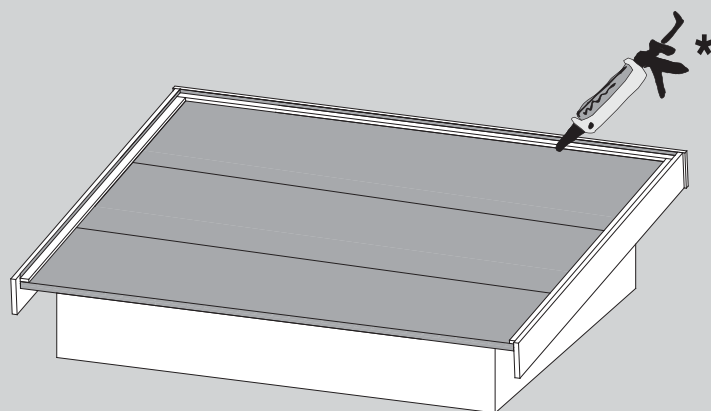
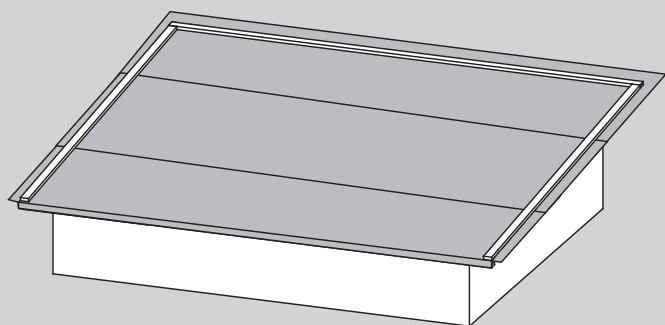
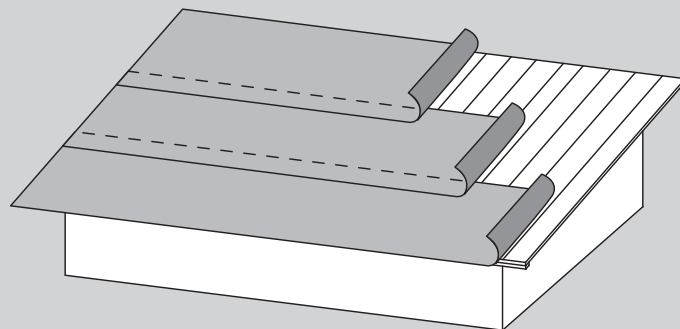
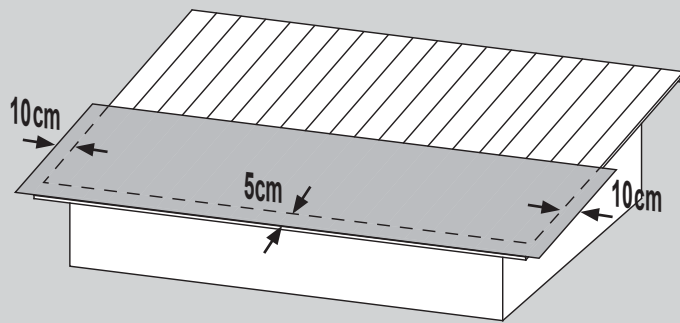

38 1x

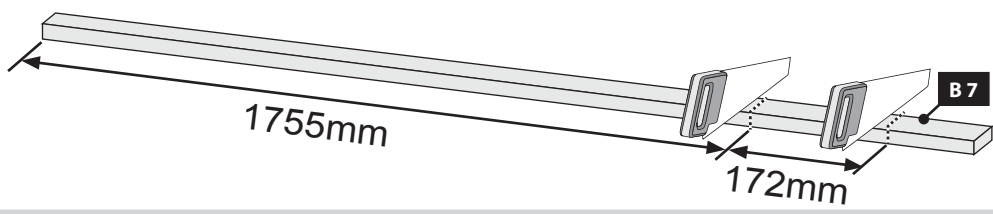

39 1x

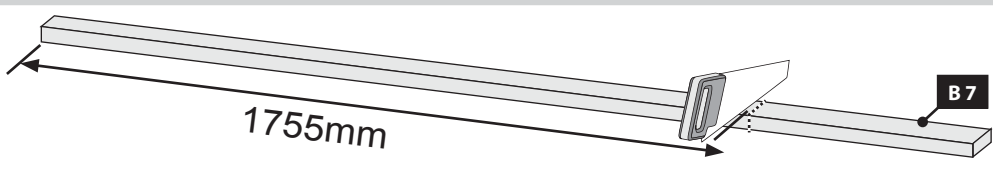

40

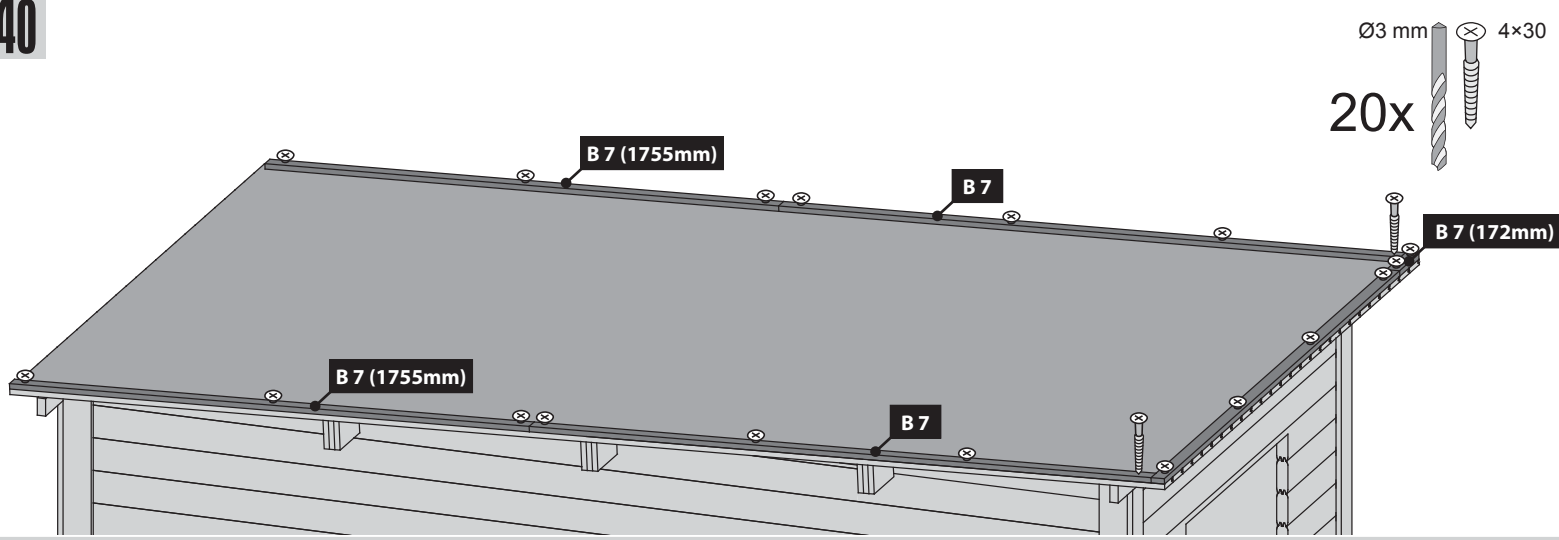

41

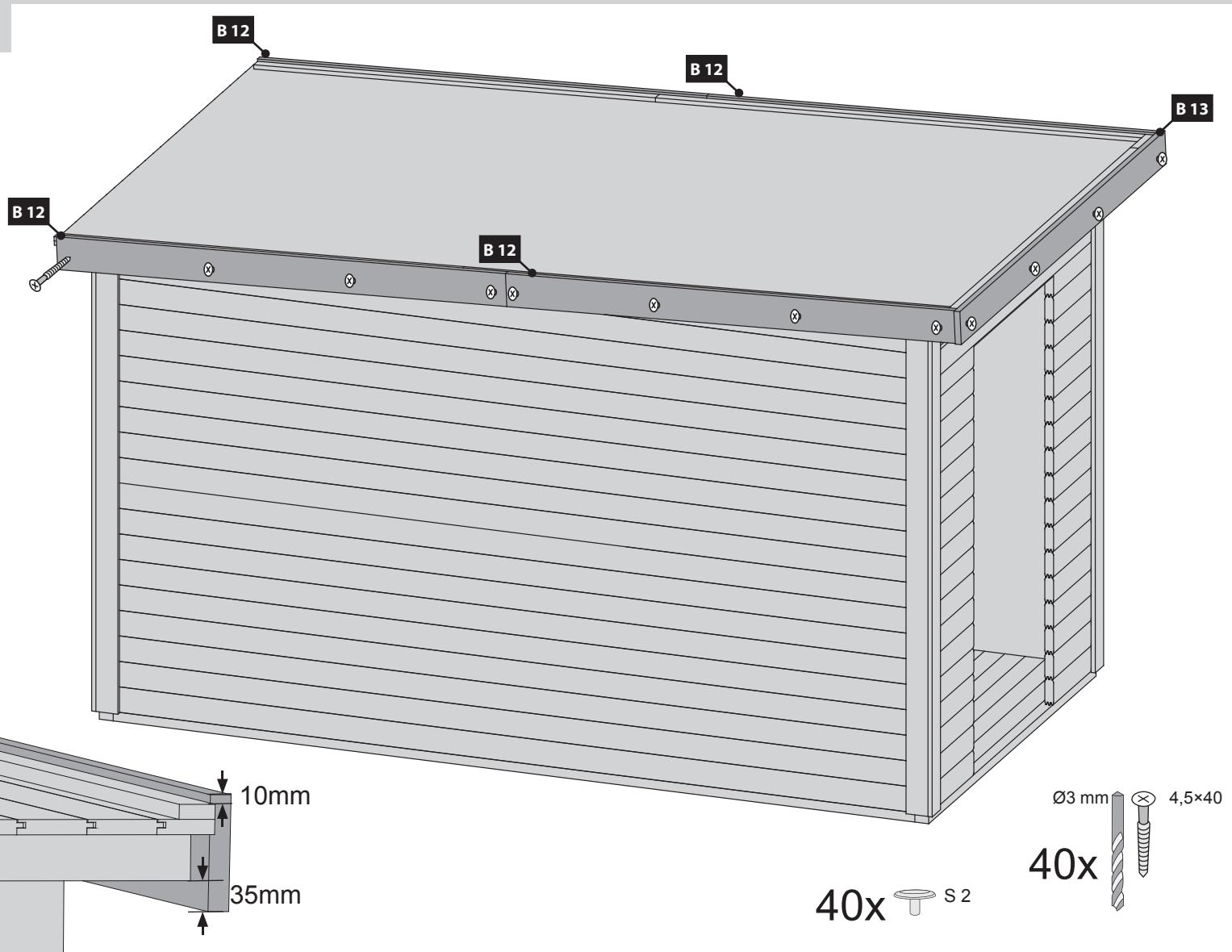

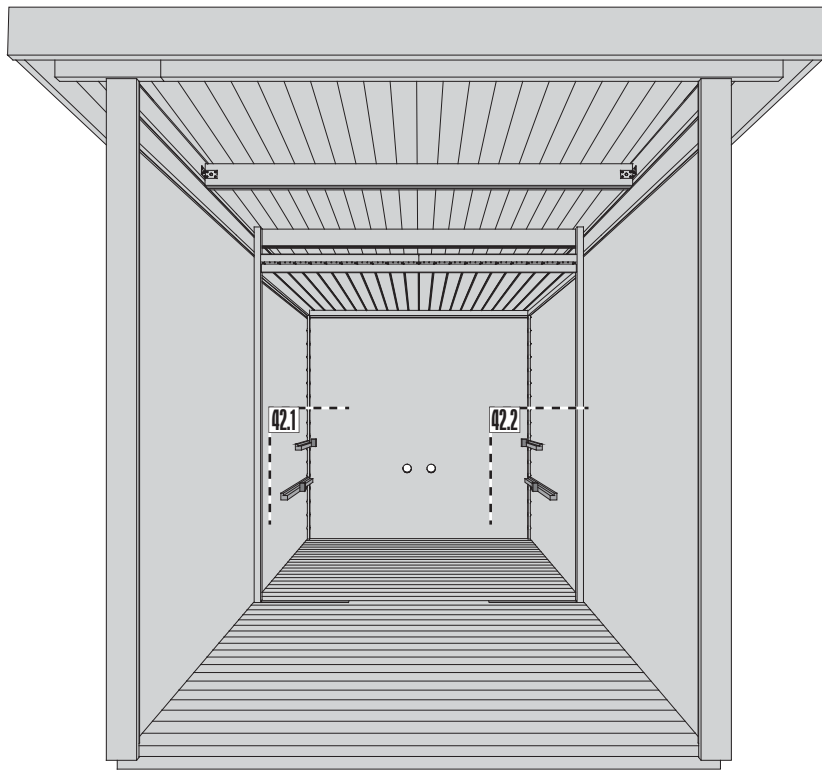

Ø5 mm 6×80
7x

42.1-1

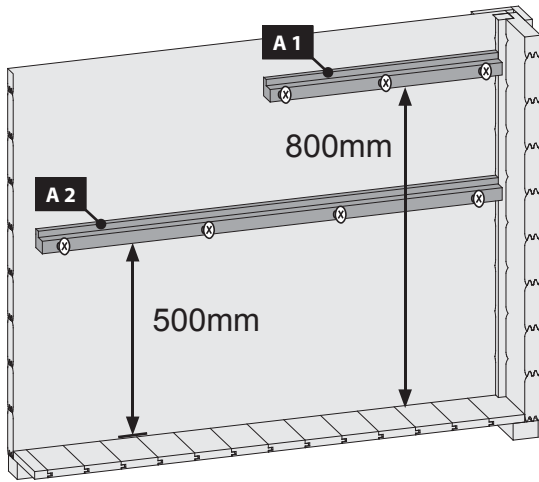

Ø5 mm 6×80
7x

42.2-1

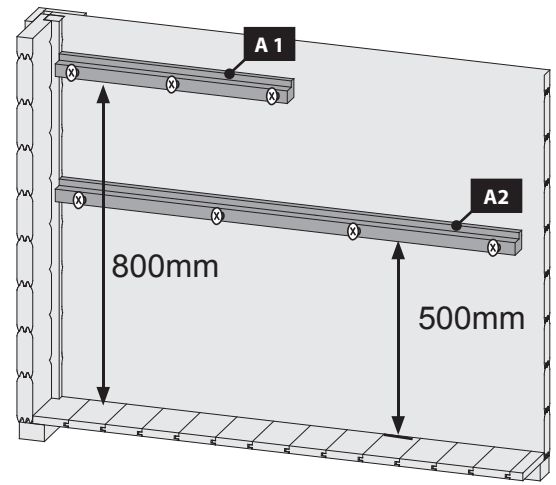

Ø3 mm 4x30
4x

42.1-2

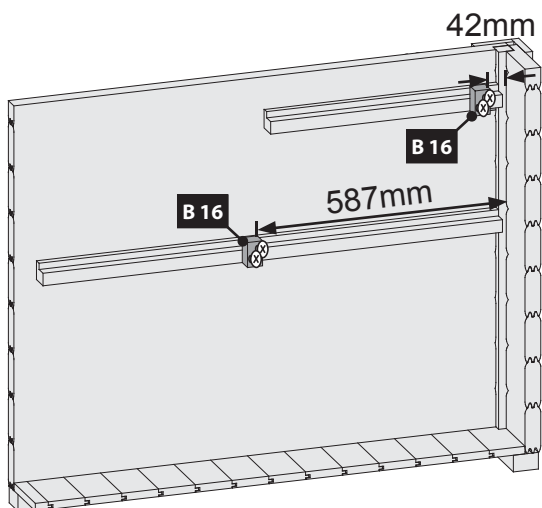

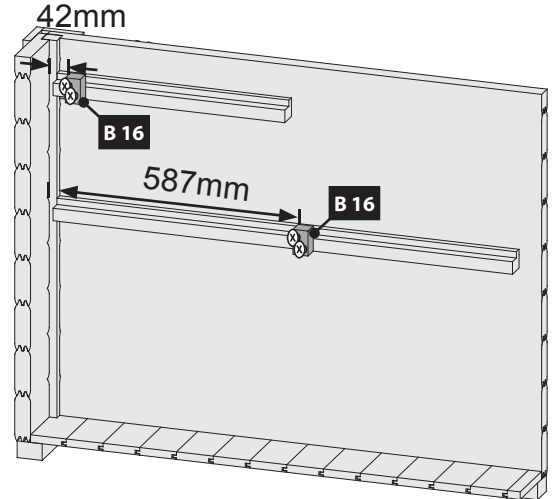

Ø3 mm 4x30
4x

42.2-2

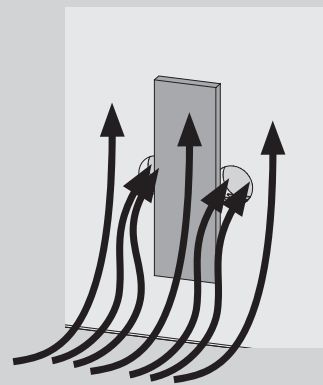
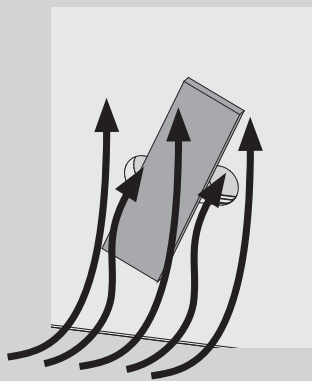
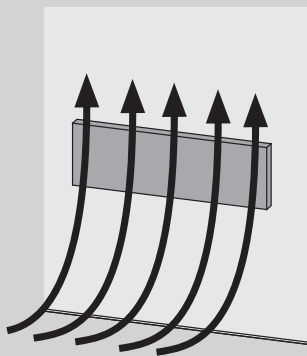
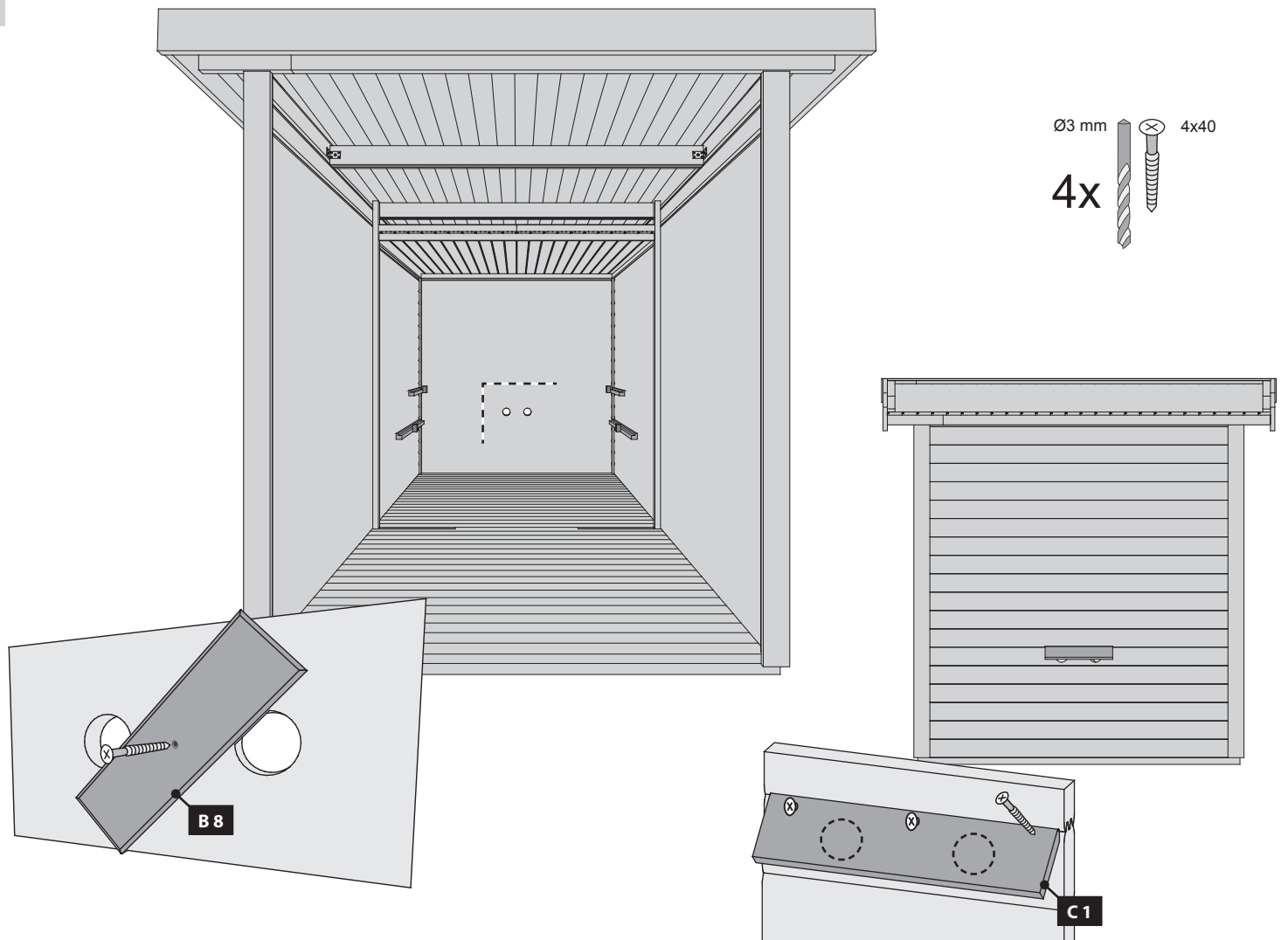





 Hier ist die Funktionsweise des Brettes abgebildet. Regeln Sie damit die Abluft nach Ihren eigenen Wünschen.

 Ceci représente le mode de fonctionnement de la planche. Avec elle, réglez l'écoulement de l'air selon vos désirs.

 This figure shows the functional principle of the board. Regulate the exhaust air according to your own wishes.

 Hier is de werking van het plankje afgebeeld. Regel daarmee de luchtafvoer naar eigen wens.

 Aquí está representada la forma de funcionamiento de la tabla. Regule con ello el aire de salida según sus propios deseos.

 Viene illustrato il principio di funzionamento della tavoletta di regolazione della ventilazione. Con essa si può regolare a piacere la ventilazione.

 Zde je zobrazená funkce desky. Regulujte s ní odsávací vzduch dle Vašeho přání.

2x

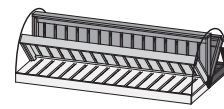
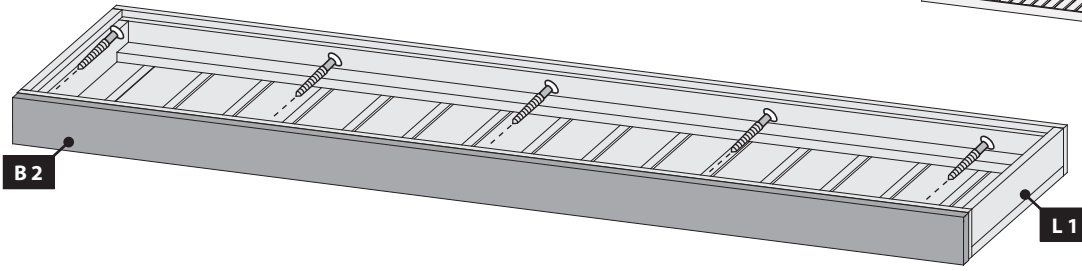

Ø3 mm 4x50
10x



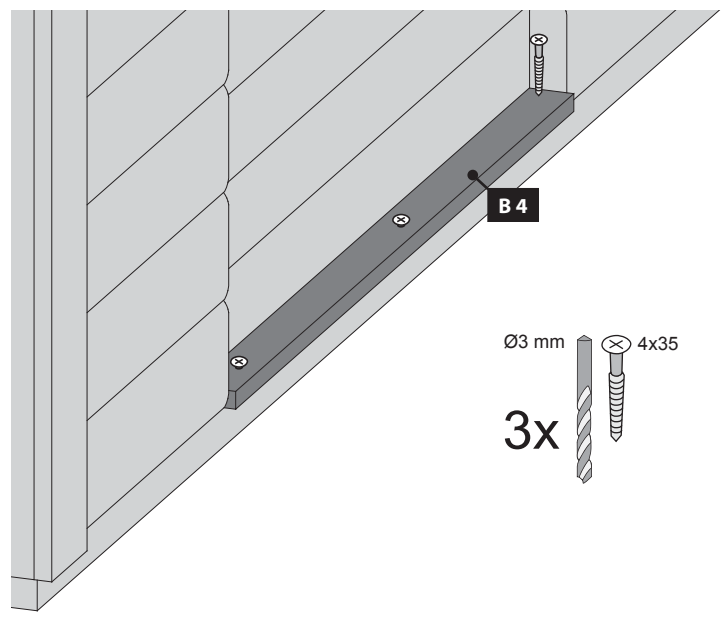
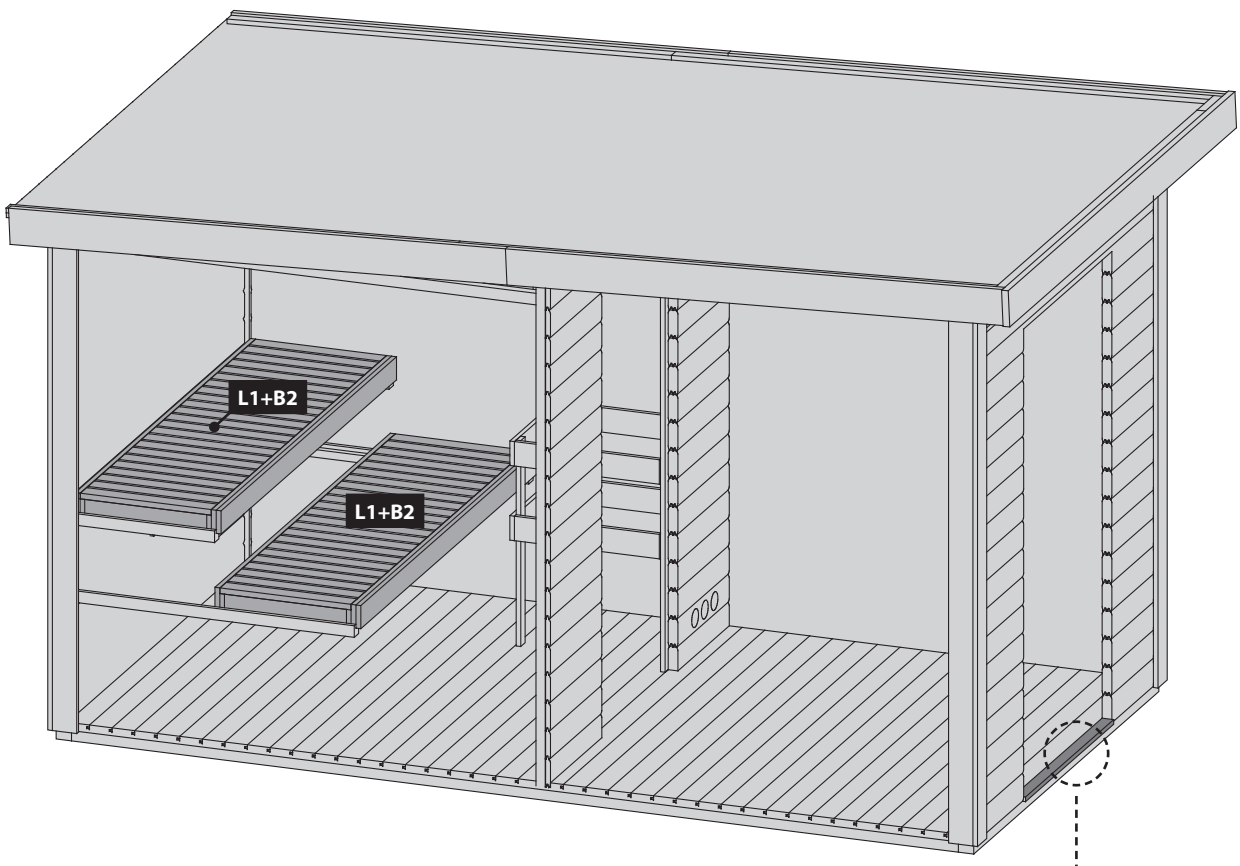

Technical drawing of a 3mm diameter drill bit and a 4x50mm screw.





Ø3 mm 4x35
3x

Technical drawing of a 3mm diameter drill bit and a 4x35mm screw.





-  Einbau Glastür
-  Installation of glass door
-  Montage porte en verre
-  Montage van de glazen deur

-  Montaje de la puerta de cristal
-  Installazione portello di vetro
-  Namestitev steklena vrata



01 — 03

46

Ø3 mm  4x35
3x 

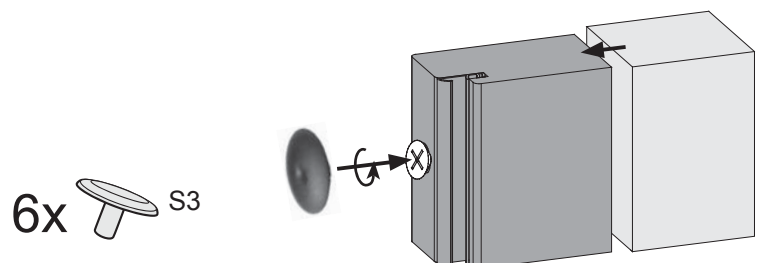
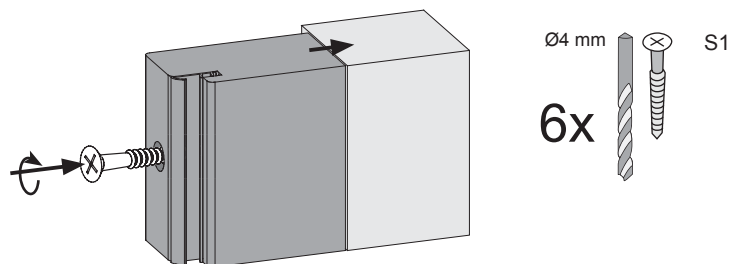
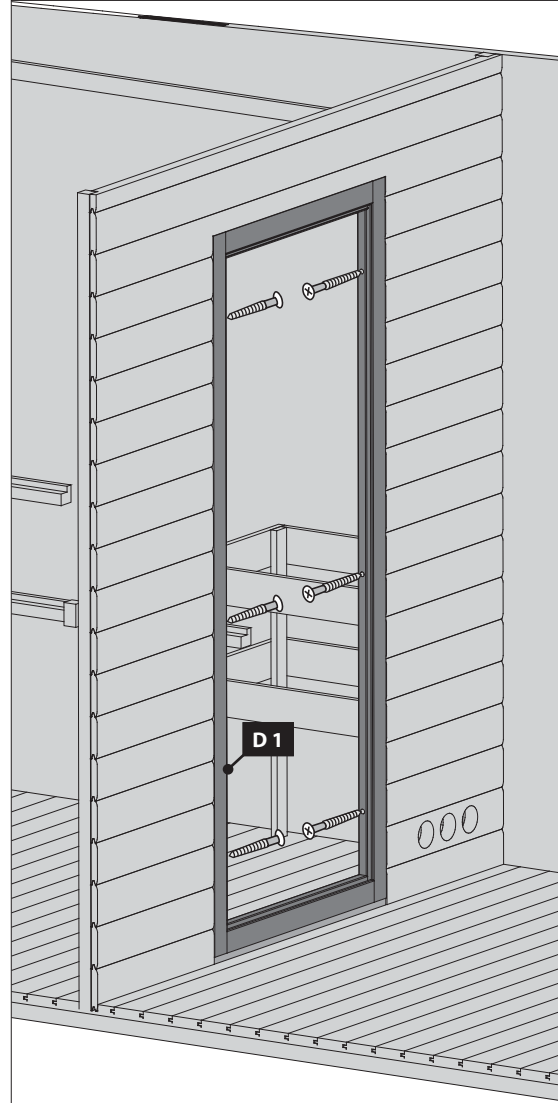
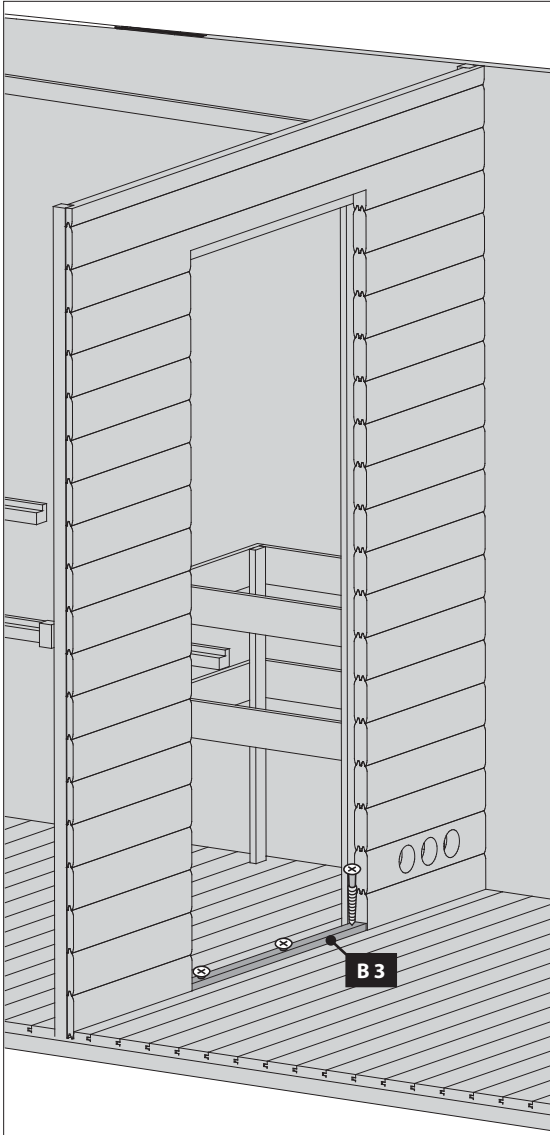

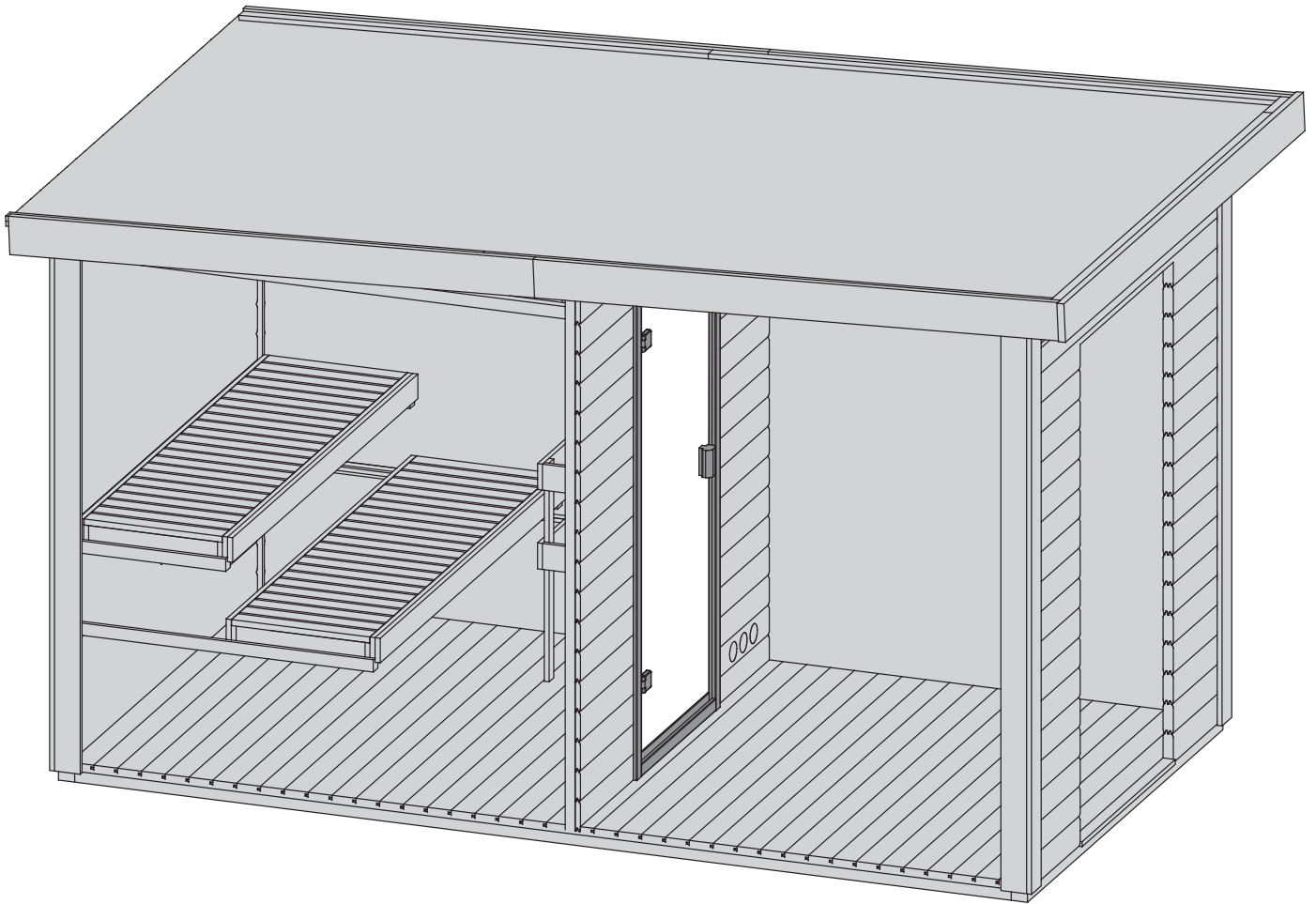

 Einbau Glastür

 Montage porte en verre

 Installation of glass door

 Montage van de glazen deur

 Montaje de la puerta de cristal

 Installazione portello di vetro

 Namestitev steklena vrata



!!! 04 — 08 **!!!**

01

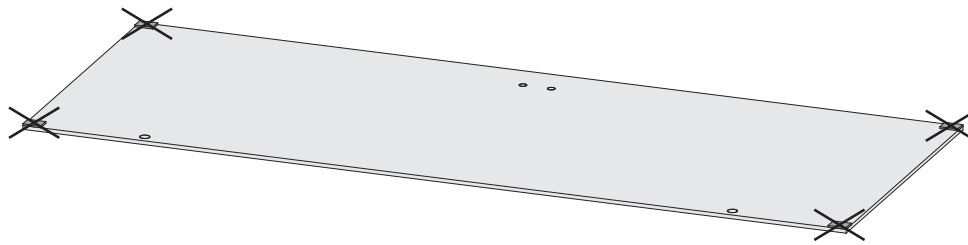



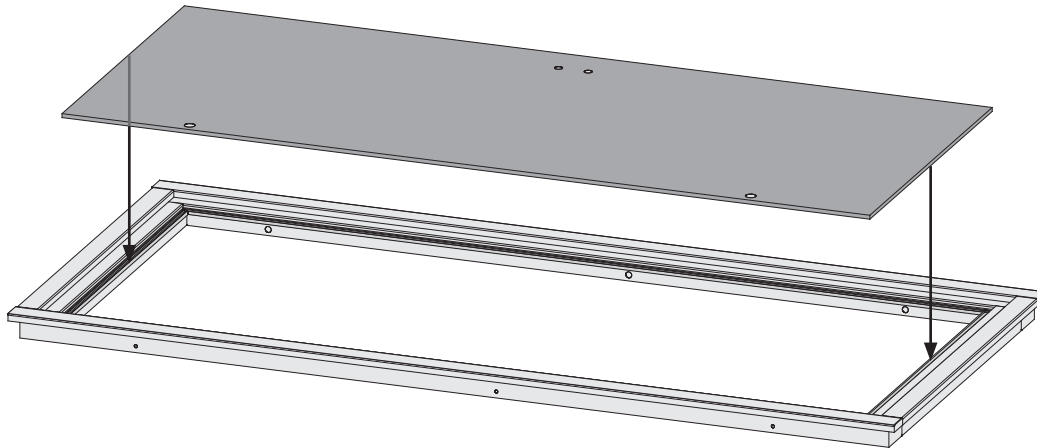

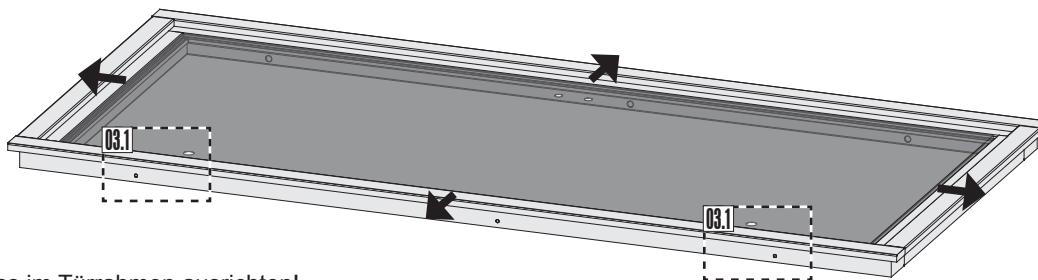

02



03



-  Das Saunatürglas im Türrahmen ausrichten!
-  Bien aligner le verre à vitre!
-  To start building up the door you need to center the glass in the wooden frame!
-  Plaats het glas van de sauna deur in het midden van het kozijn!
-  ¡Centrar la puerta de cristal dentro del marco!
-  Allineare il vetro dello sportello sauna al telaio della porta!
-  Skleněná dvířka sauna v zárubně zarovnáni!

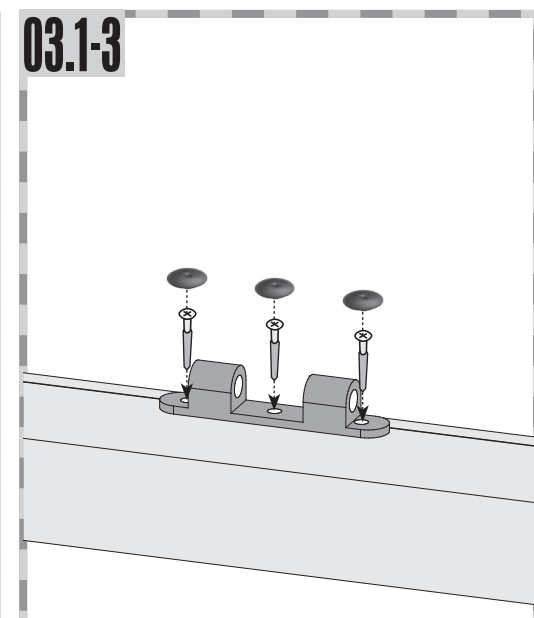
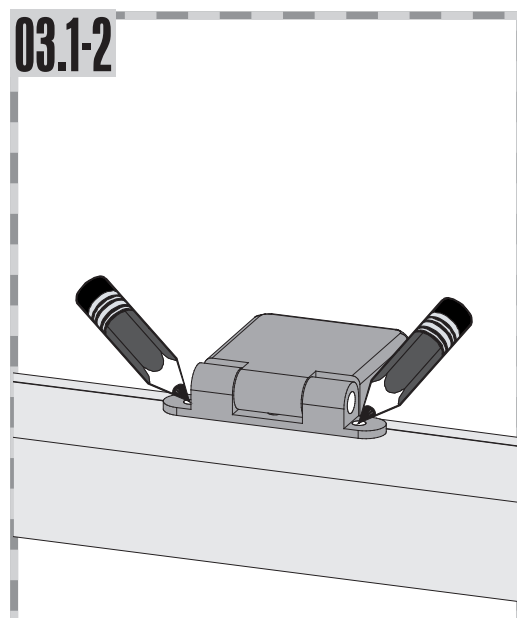
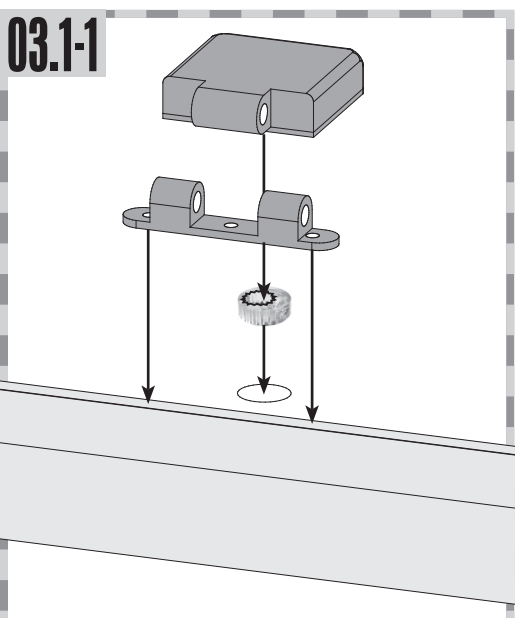

 Einbau Saunatür

 Sauna deur installatie

 Sauna Instalace dveře

 Installation de porte Sauna

 Instalación de la puerta Sauna

 Sauna door installation

 Installazione porta Sauna

04

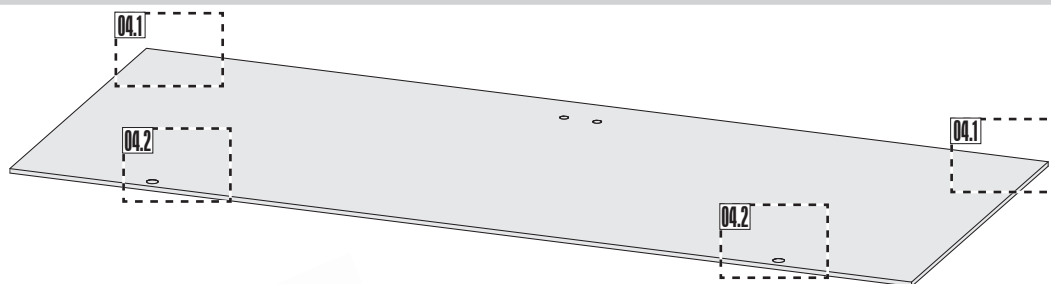

04.1-1

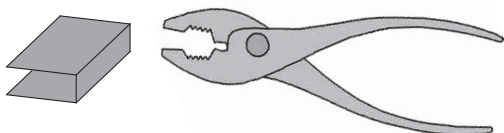

04.1-2

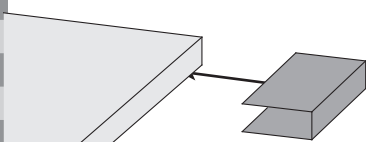

04.1-3

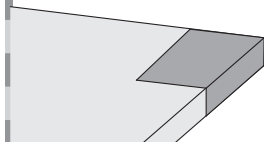

04.2-1

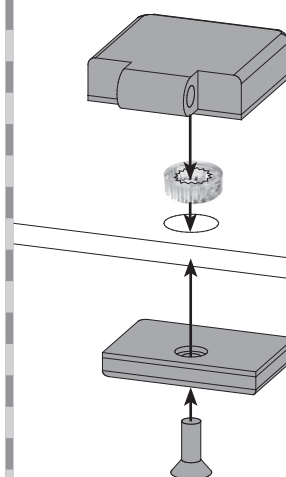

04.2-2

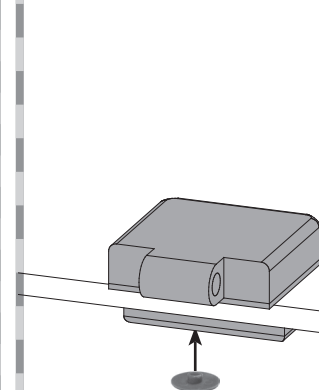

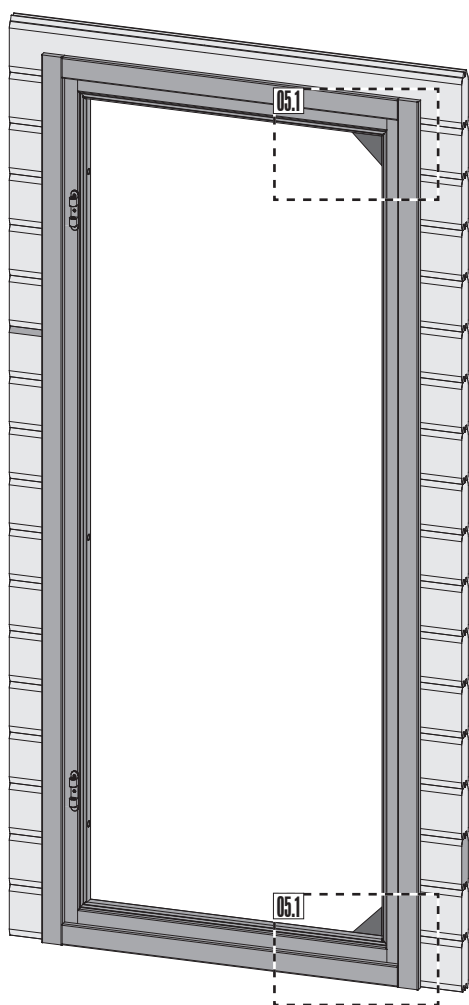

05





 Achtung: Alle Verstell-Excenter müssen in der Glasscheibe die gleiche Grundstellung haben!

 Attention: Tous les excenteurs de positionnement doivent avoir la même position de base dans la vitre!

 Attention: All adjustable eccentrics must have the same basic adjustment in the glass panel!

 Figyelmeztetés: az állítható excentrikusok ugyanabban a helyzetben kell, hogy legyenek a üveglapon!

 Atención: Todos los excéntricos regulables tienen que tener la misma posición base en la hoja de cristal.

 Attenzione: Tutti gli eccentrici di regolazione devono avere la stessa posizione base nella lastra di vetro!

 Poznámka: Všechny nastavovací podivínů musí mít stejný základní polohy ve skle!

05.1-1

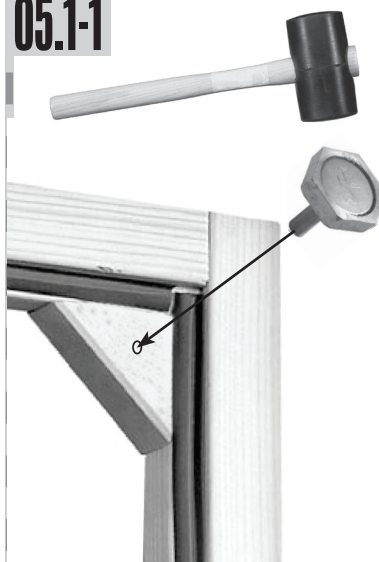

05.1-2



 Einbau Saunatür

 Sauna deur installatie

 Sauna Instalace dveře

 Installation de porte Sauna

 Instalación de la puerta Sauna

 Sauna door installation

 Installazione porta Sauna

06

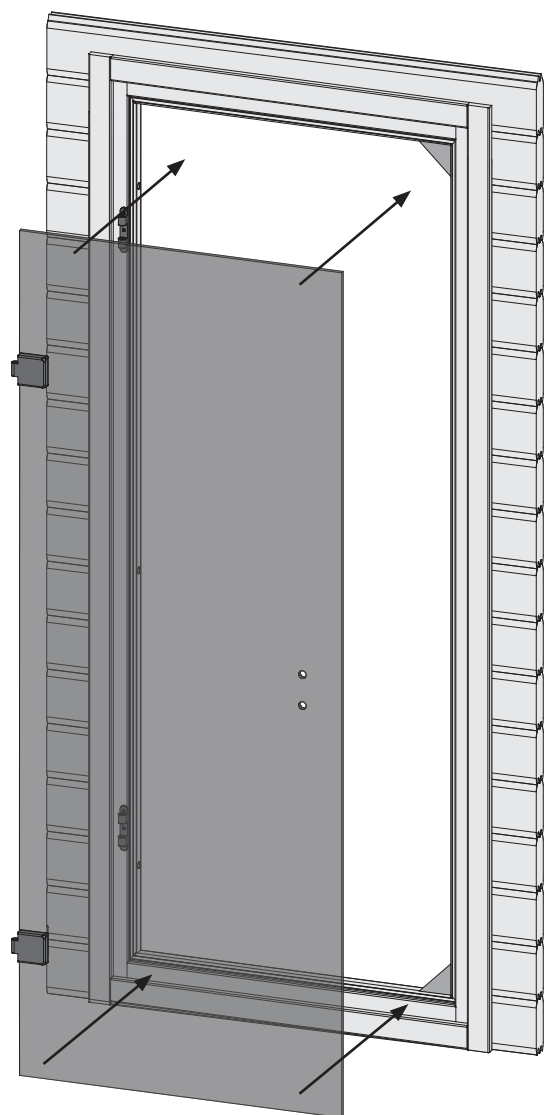

07

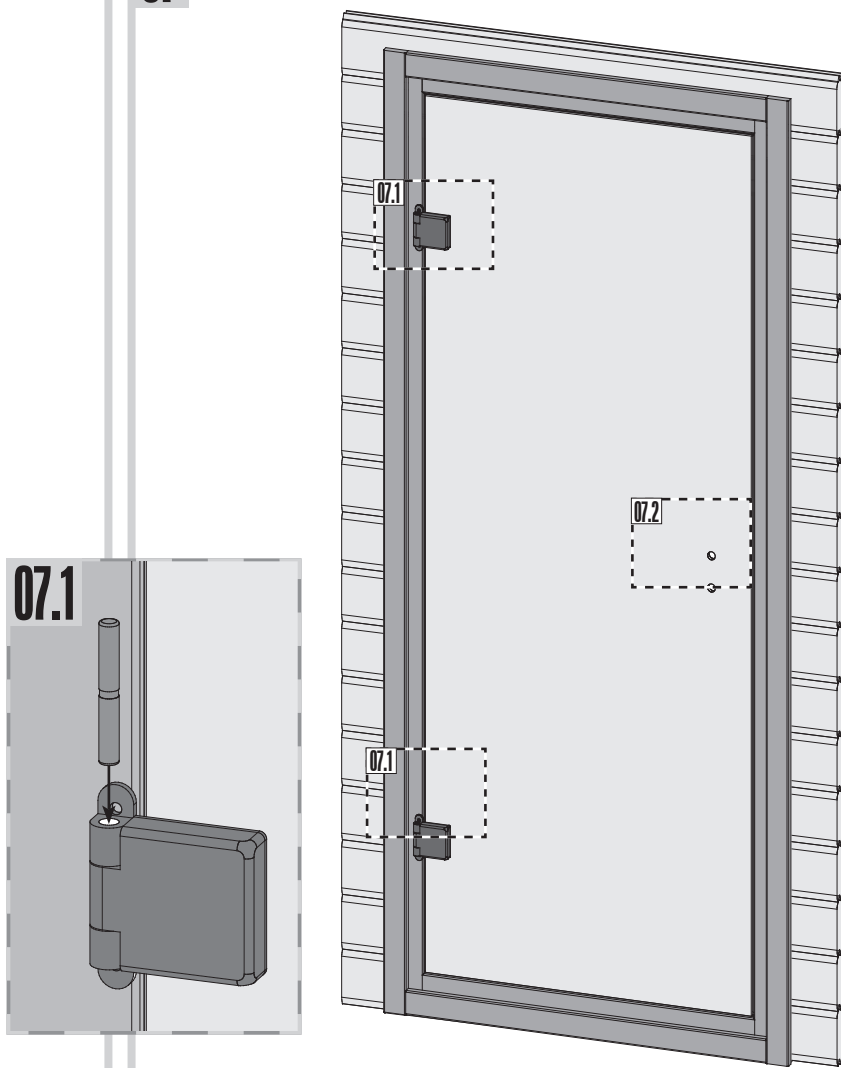

07.2-1

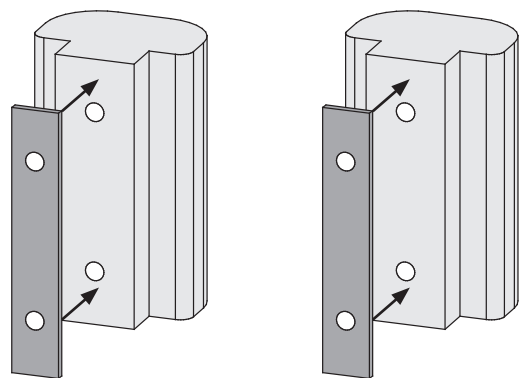

07.2-2

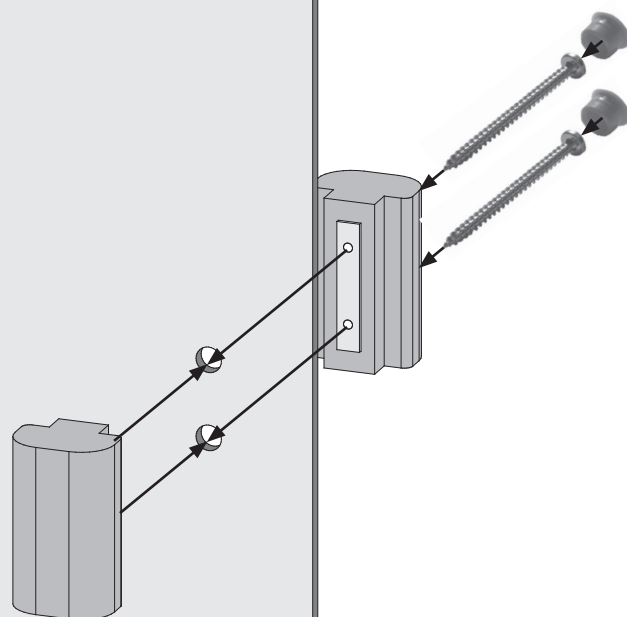

 Einbau Saunatür

 Sauna deur installatie

 Sauna Instalace dveře

 Installation de porte Sauna

 Instalación de la puerta Sauna

 Sauna door installation

 Installazione porta Sauna

08

 **Seitenverstellung + Höhenverstellung**

Achtung: Alle Verstell-Excenter müssen in der Glasscheibe die gleiche Grundstellung haben!

 **Positionnement latéral + positionnement hauteur**

Attention: Tous les excentrés de positionnement doivent avoir la même position de base dans la vitre!

 **Lateral adjustment + height adjustment**

Attention: All adjustable eccentrics must have the same basic adjustment in the glass panel!

 **Zijverstelling + hoogteverstelling**

Attentie: alle excentrische verstelelementen moeten in dezelfde stand in de glasplaat worden geplaatst!

 **Regulación lateral + regulación de la altura**

Atención: Todos los excéntricos regulables tienen que tener la misma posición base en la hoja de cristal.



 **Regolazione laterale + regolazione dell'altezza**



Attenzione: Tutti gli eccentrici di regolazione devono avere la stessa posizione base nella lastra di vetro!

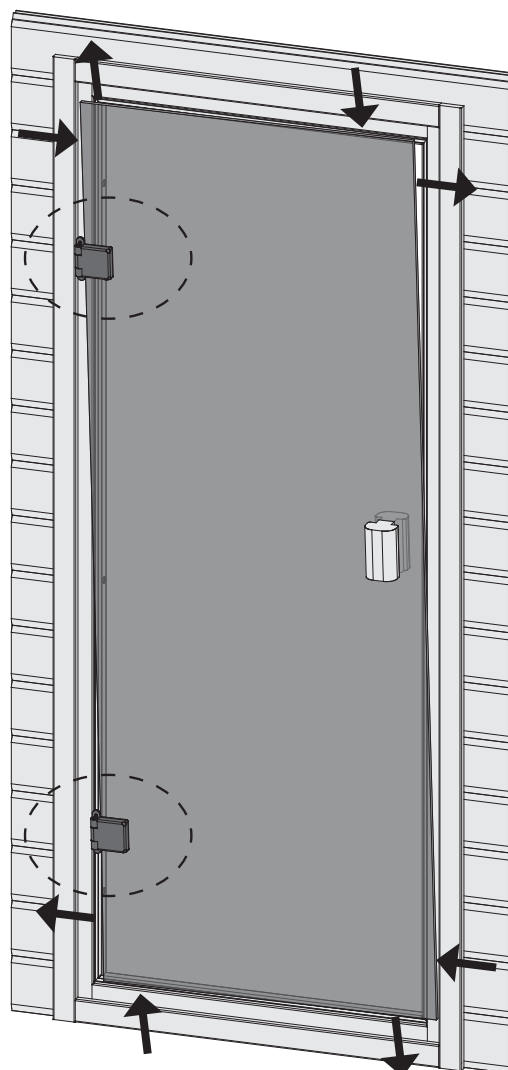
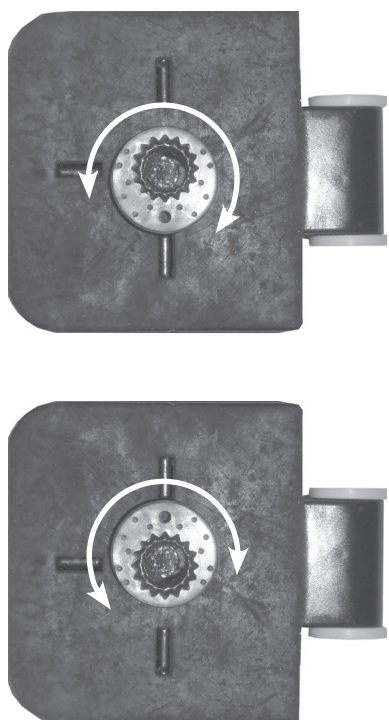

 **Boční nastavení + nastavení výšky**

Poznámka: Všechny nastavovací podivínů musí mít stejný základní polohy ve skle!







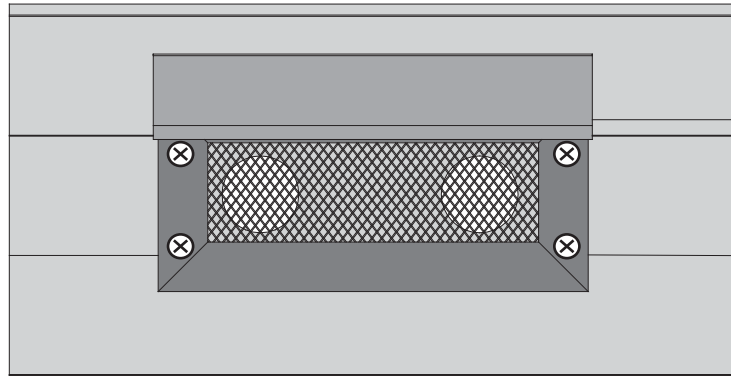
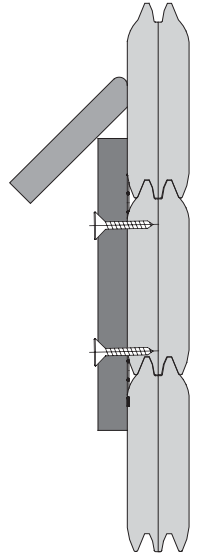
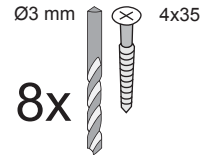
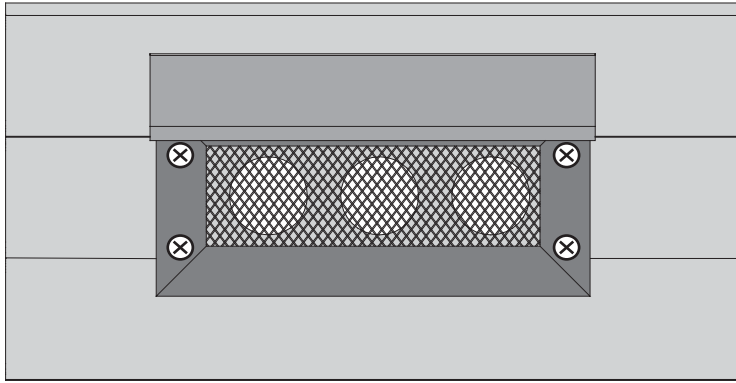

-  Saunahaus ohne Vorraum
-  Saunahuis zonder voorkamer
-  Sauna sans antichambre



-  Sauna Sin antesala
-  Sauna house without anteroom
-  Sauna senza antibagno

-  Saunový dům bez předsíně
-  Sauna hus uden anteroom



-  Saunahaus mit Vorraum
-  Saunahuis met voorkamer
-  Sauna avec antichambre

-  Sauna con antesala
-  Sauna house with anteroom
-  Sauna con antibagno

-  Saunový dům s předsíní
-  Sauna hus med anteroom

