

# 80364 83035

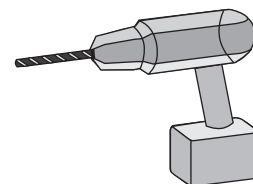

**Aufbauanleitung**

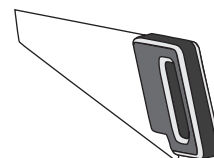
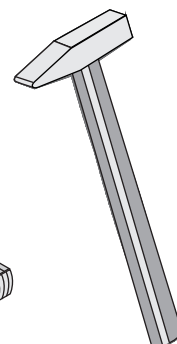
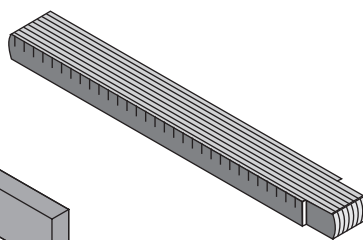
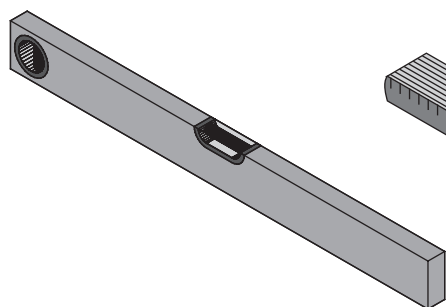
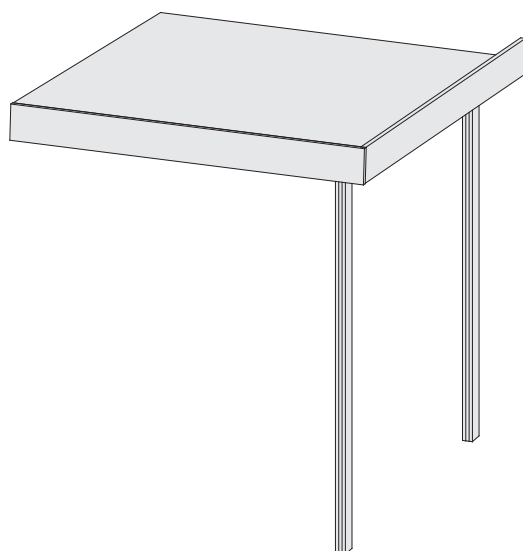

**notice de montage**



**Building Instructions**



**montagehandleiding**



**Instrucciones de construcción**



**Istruzioni per il montaggio**



**Montážní návod**



**Service-Hotline: +49 421 38693 33**



Vergleichen Sie zuerst die Material-liste mit Ihrem Paketinhalt! Bitte haben Sie Verständnis, dass Beanstandungen nur im nicht aufgebauten Zustand bearbeitet werden können!



En primer lugar, compare la lista de material con el contenido del paquete. Rogamos entienda que las reclamaciones sólo pueden ser tramitadas antes de montar el objeto!



Nejprve přezkontrolujte obsah balení podle materiálového listu! Mějte pochopení pro to, že případnou reklamaci se můžeme zabývat pouze tehdy, když díly nebudou smontované! Za pomoci tohoto seznamu můžete jednotlivé díly přiřadit k montážnímu návodu.



Vergelijk eerst de lijst van materialen met de inhoud van uw pakket! Reclamaties kunnen alleen in behandeling worden genomen zolang de onderdelen nog niet zijn gemonteerd!



First compare the list of materials with your package contents! Please understand that complaints can be processed in the non-built status only!



Commencez par comparer la liste du matériel avec le contenu de votre paquet! Sachez que nous traitons uniquement les réclamations concernant le matériel à l'état non monté!



Confrontate questa distinta materiali prima con il contenuto del pacchetto! Vi preghiamo di comprendere che eventuali reclami possono essere accolti solo prima del montaggio!

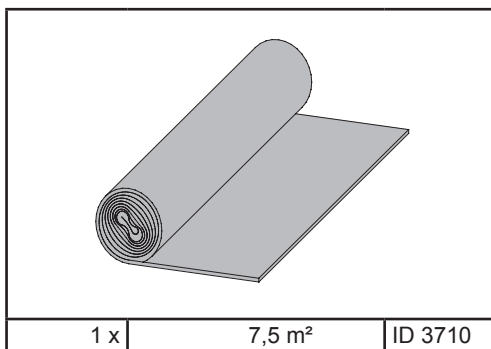
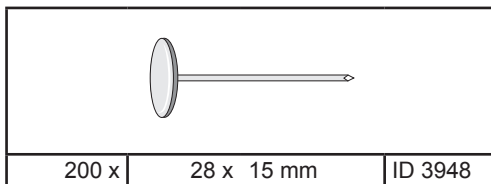
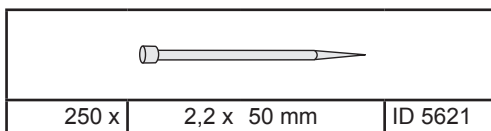
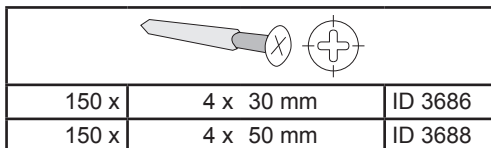
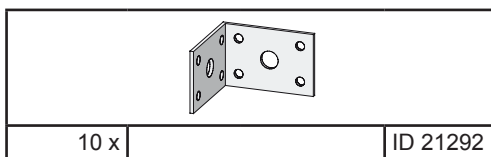
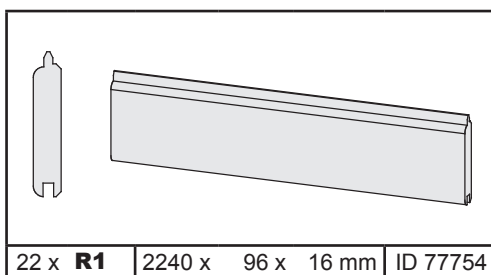
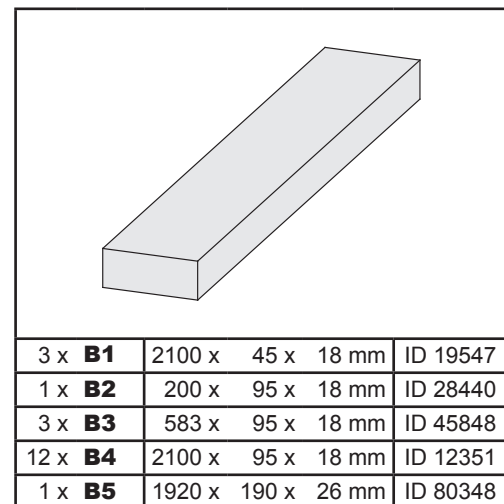
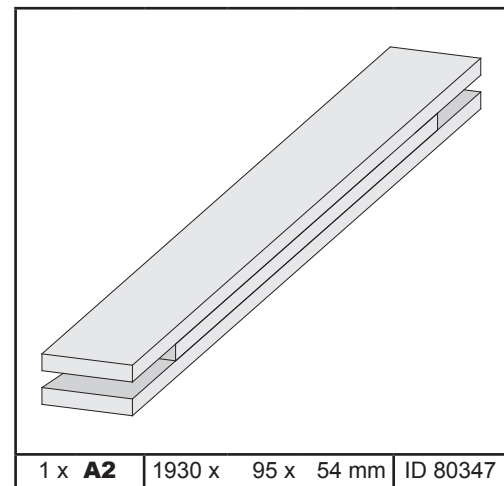
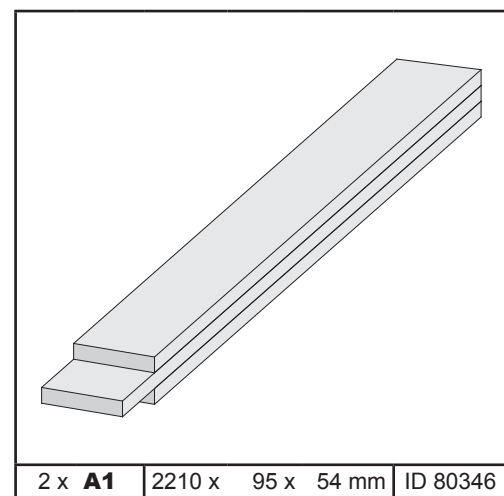
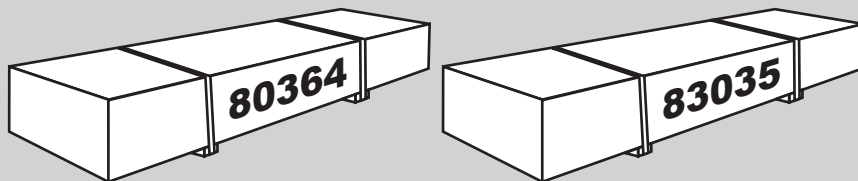

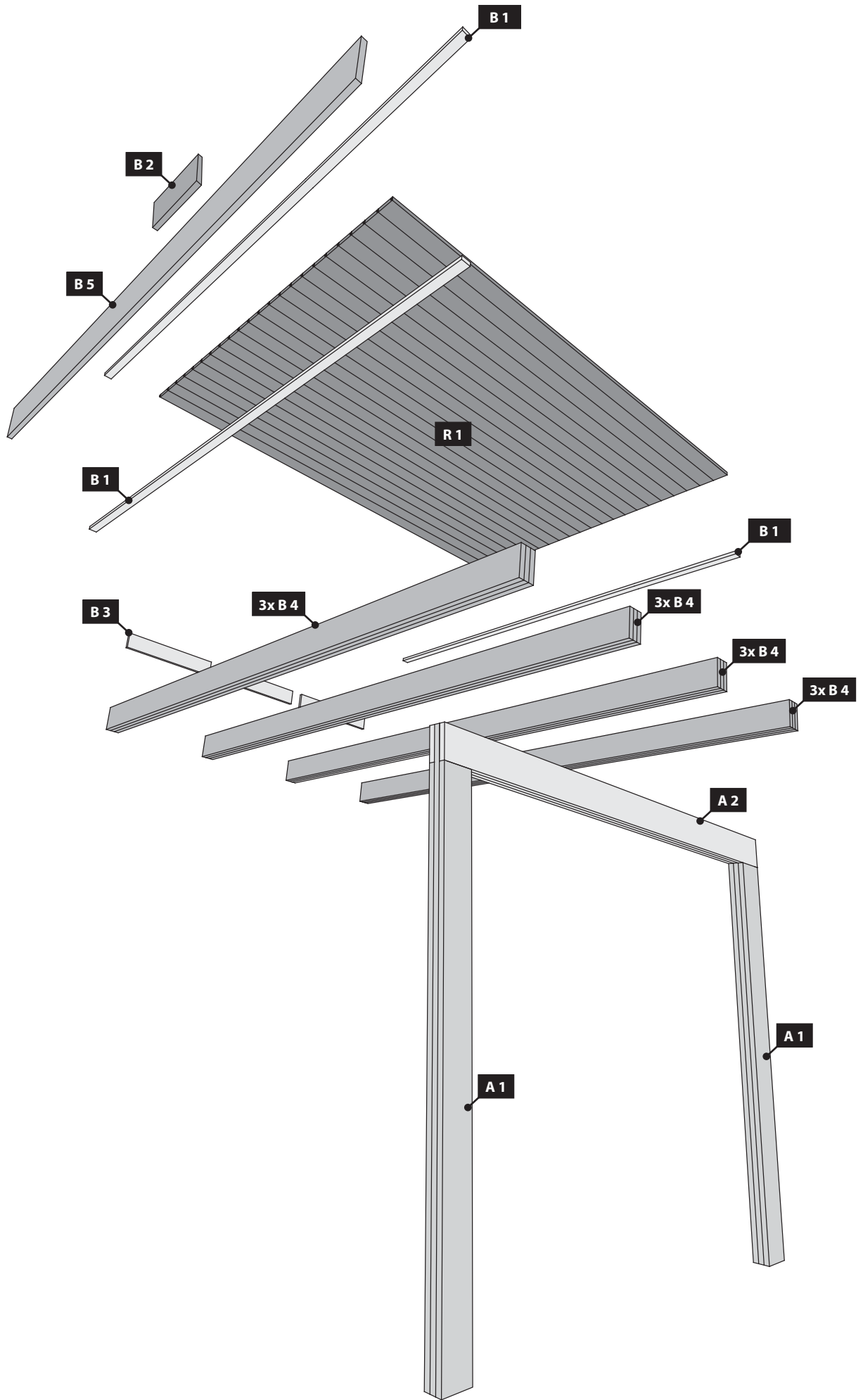

-  Geeignet für
-  geschikt voor
-  Suitable for
-  adapté pour
-  adecuado para
-  adatto per
-  vhodné pro

**79768** 14.09.2017



-  Aufbauanleitung
-  notice de montage
-  Building Instructions
-  montagehandleiding
-  instrucciones de construcción
-  Istruzioni per il montaggio
-  Montážní návod
-  Service-Hotline: +49 421 38693 33

**80563** 14.09.2017



-  Aufbauanleitung
-  notice de montage
-  Building Instructions
-  montagehandleiding
-  instrucciones de construcción
-  Istruzioni per il montaggio
-  Montážní návod
-  Service-Hotline: +49 421 38693 33

**80564** 27.07.2017



-  Aufbauanleitung
-  notice de montage
-  Building Instructions
-  montagehandleiding
-  instrucciones de construcción
-  Istruzioni per il montaggio
-  Montážní návod
-  Service-Hotline: +49 421 38693 33

**80568 80987** 14.09.2017







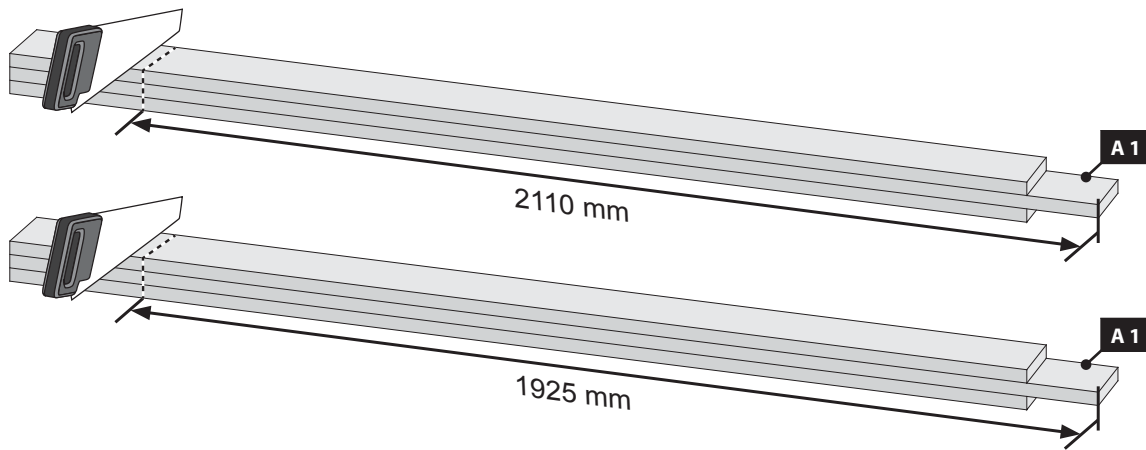

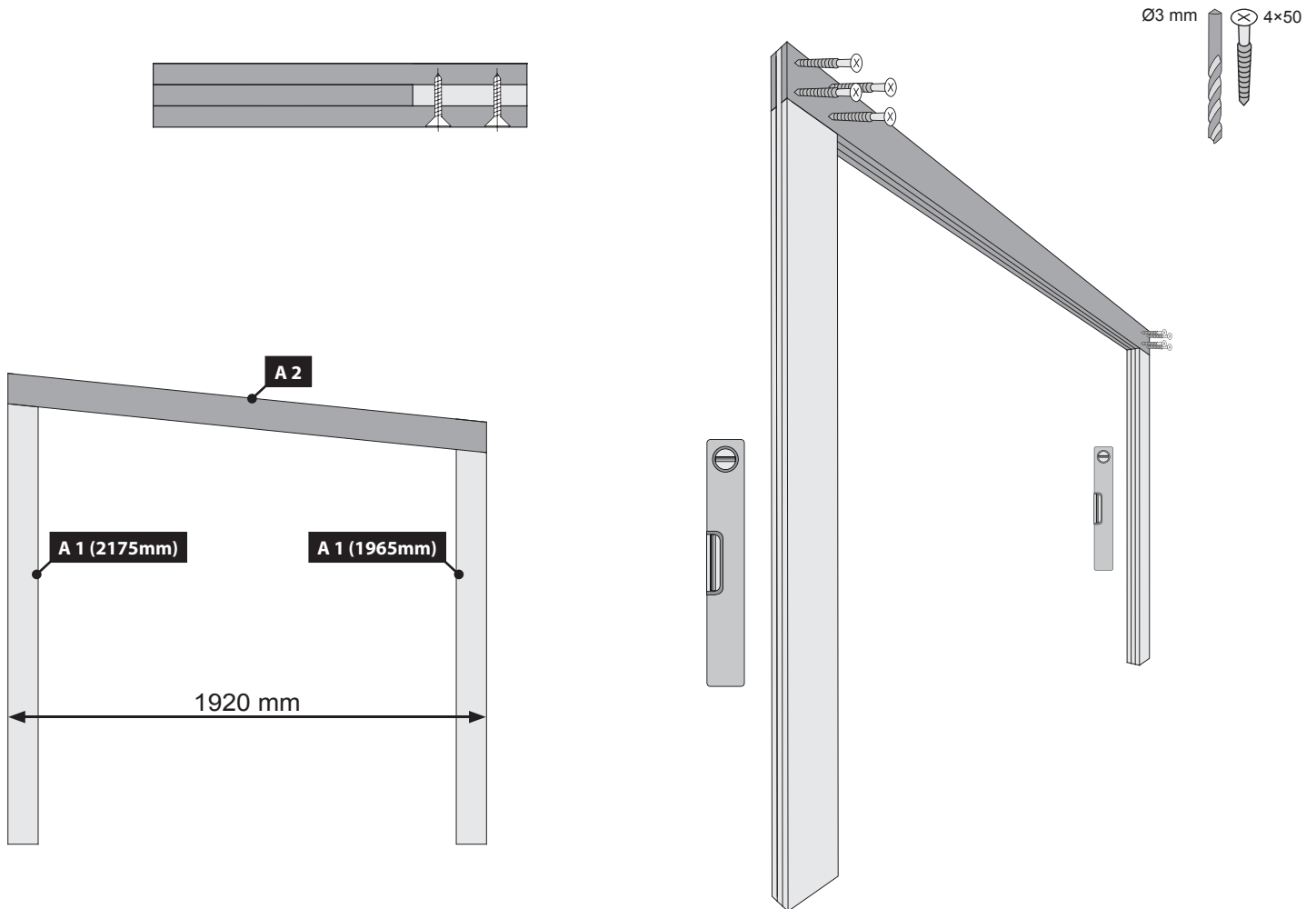

-  Aufbauanleitung
-  notice de montage
-  Building Instructions
-  montagehandleiding
-  instrucciones de construcción
-  Istruzioni per il montaggio
-  Montážní návod
-  Service-Hotline: +49 421 38693 33

# 01



# 02



-  Draufsicht
-  vista desde arriba
-  bovenaanzicht
-  vista dall'alto
-  Top view
-  pŕdorys
-  vue de dessus

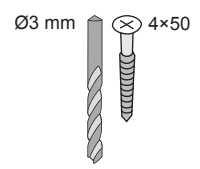
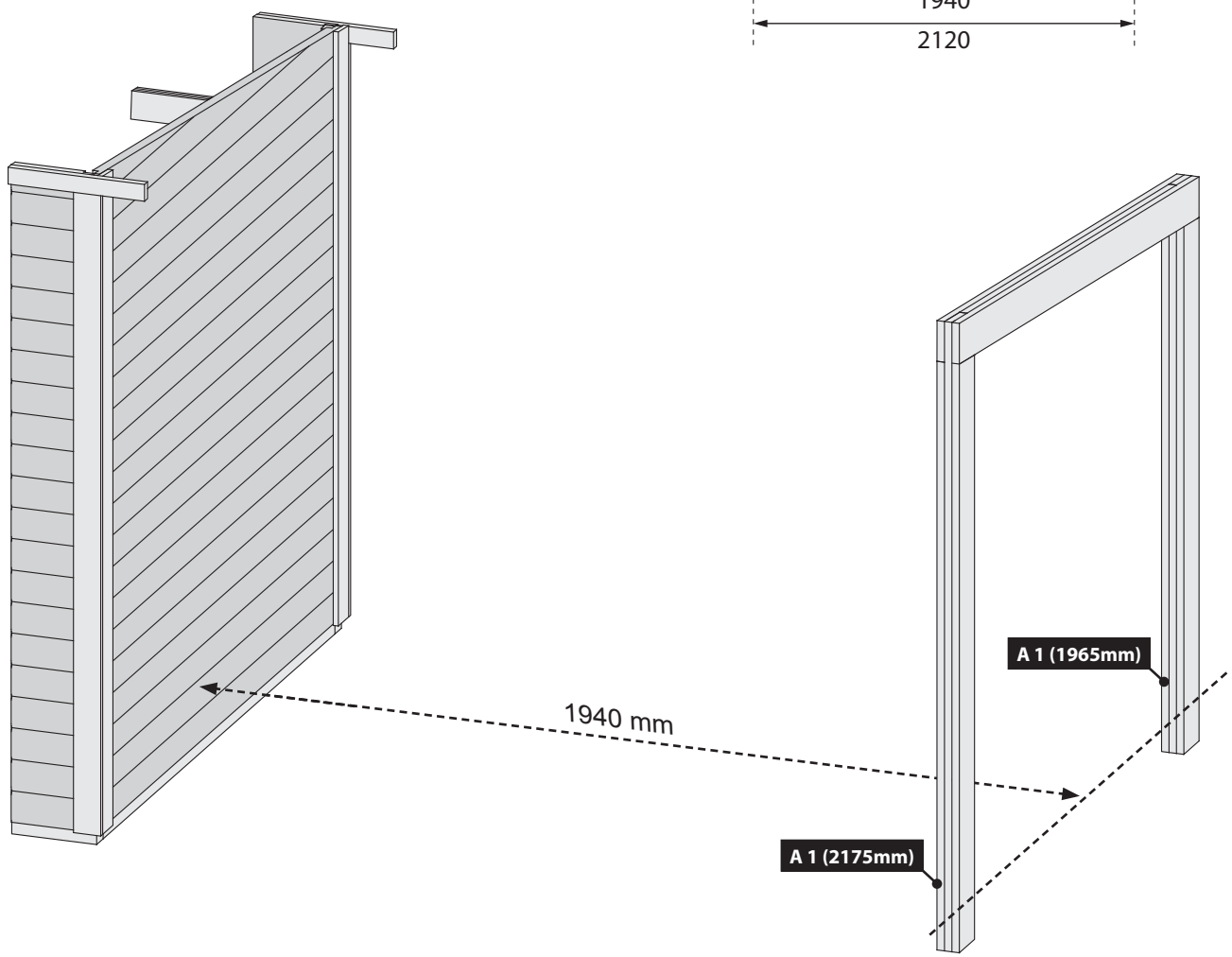
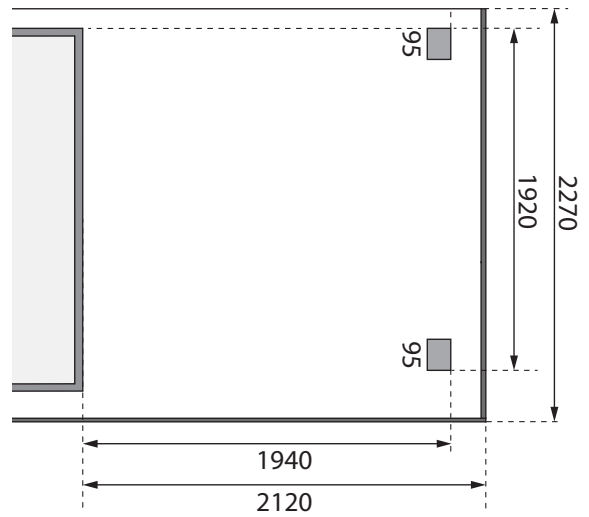

Bündig!  
Affleurement!  
Gelijk!  
Aras!  
Flush!  
Combacia!  
Flush!

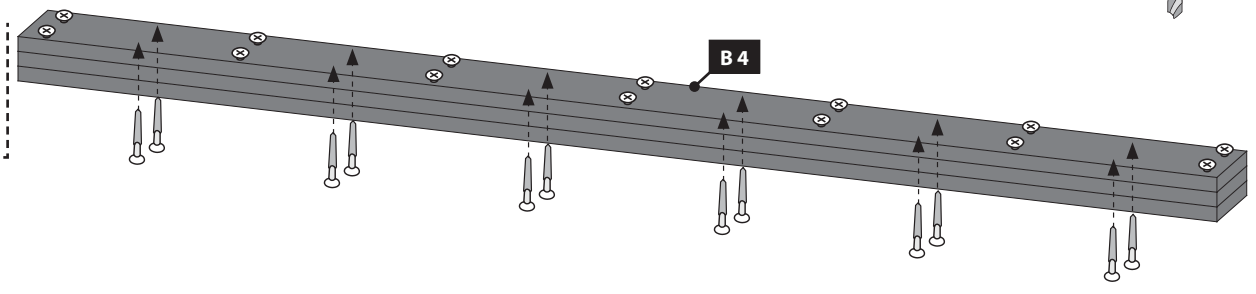

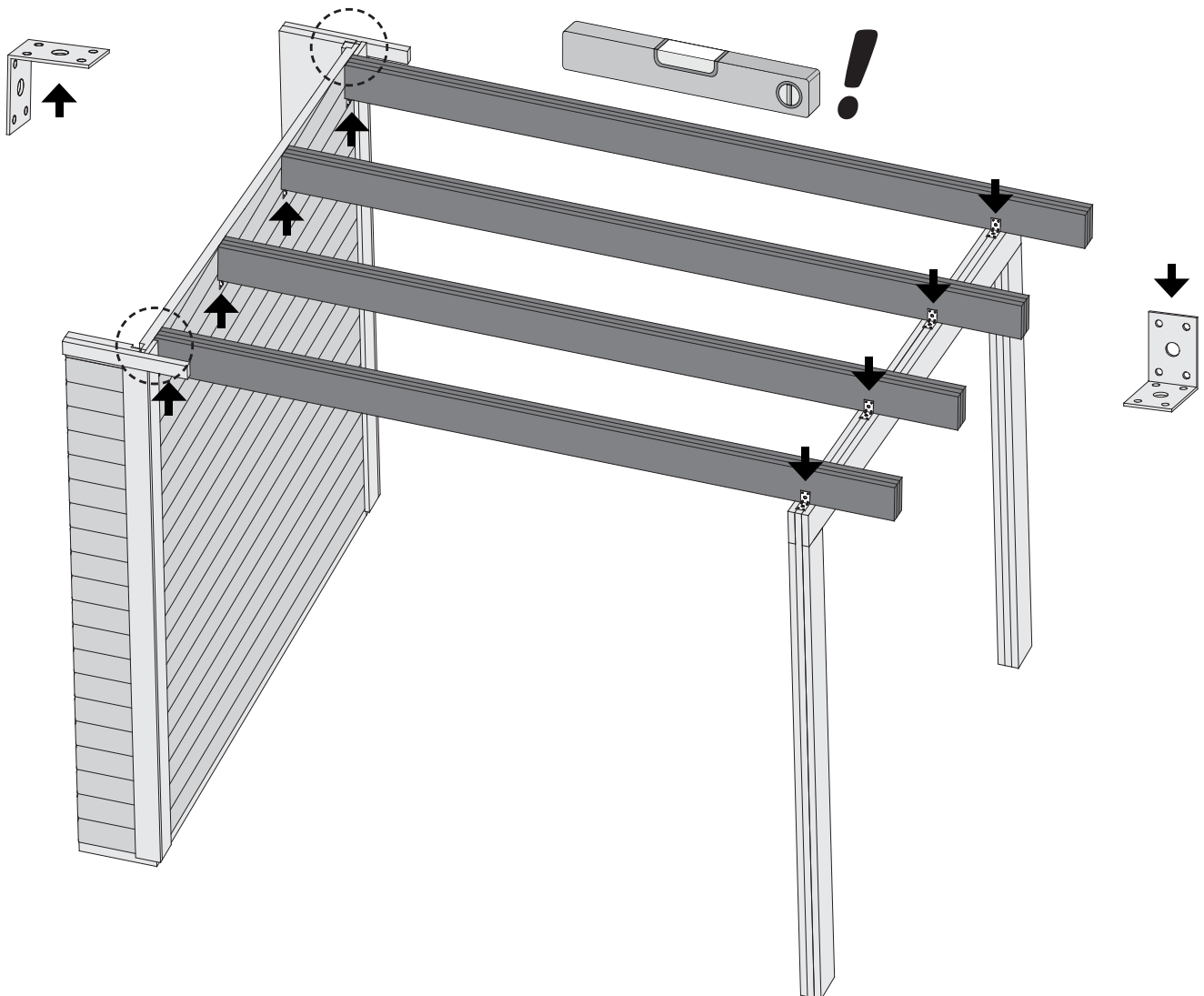
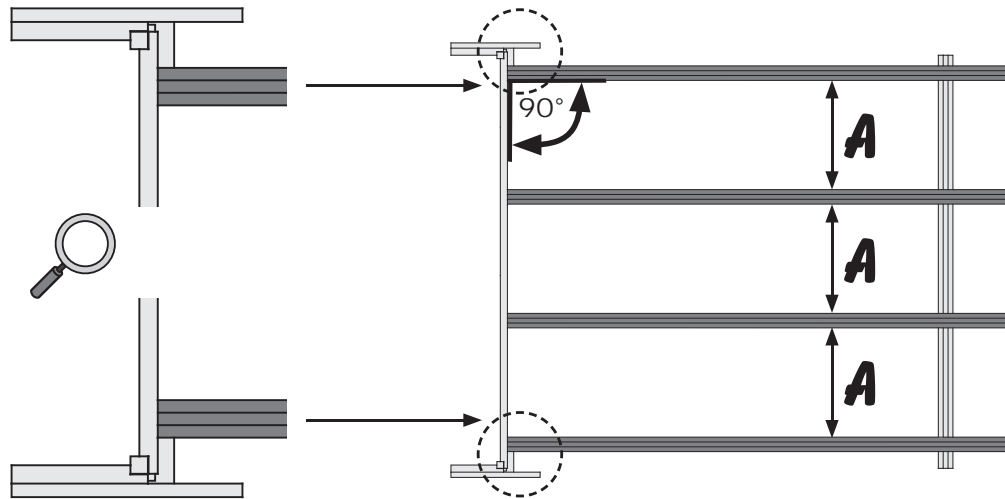
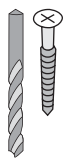

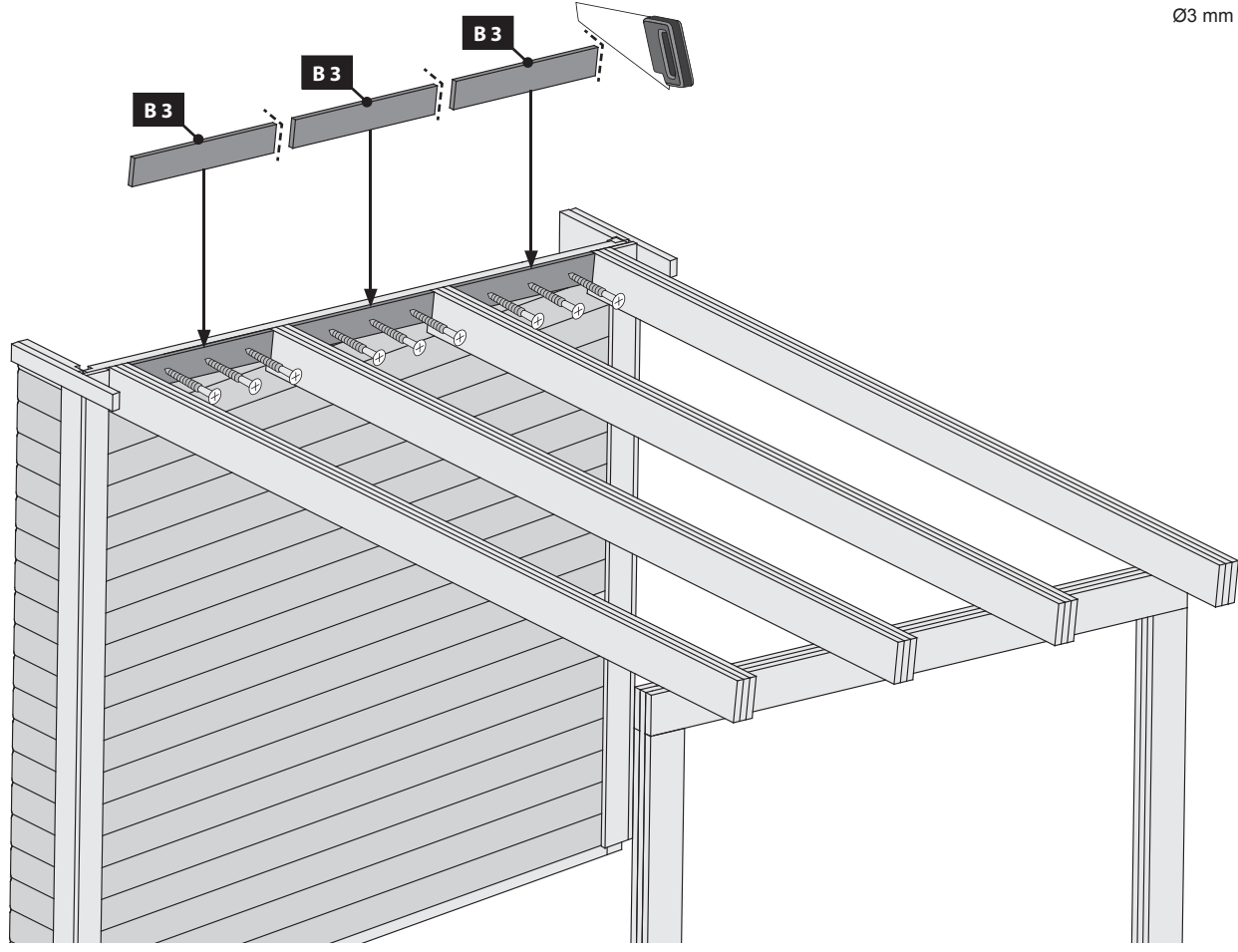

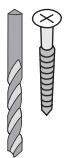
Ø3 mm  4x30



-  Schmale Seite nach oben
-  Estrecha hacia arriba
-  Narrow side up
-  Stretta verso l'alto
-  Narrow vers le haut
-  Úzká stranou nahoru
-  Smalle kant naar boven

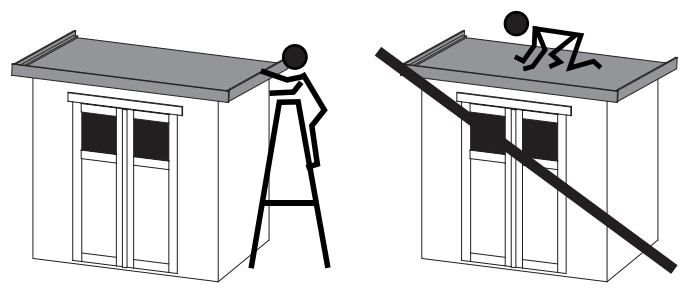

Bündig!  
Affleurement!  
Gelijk!  
Aras!  
Flush!  
Combacia!  
Stejný!

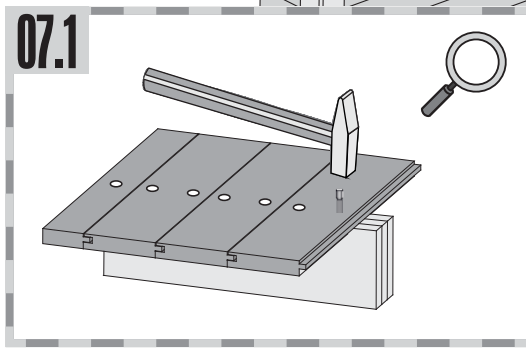
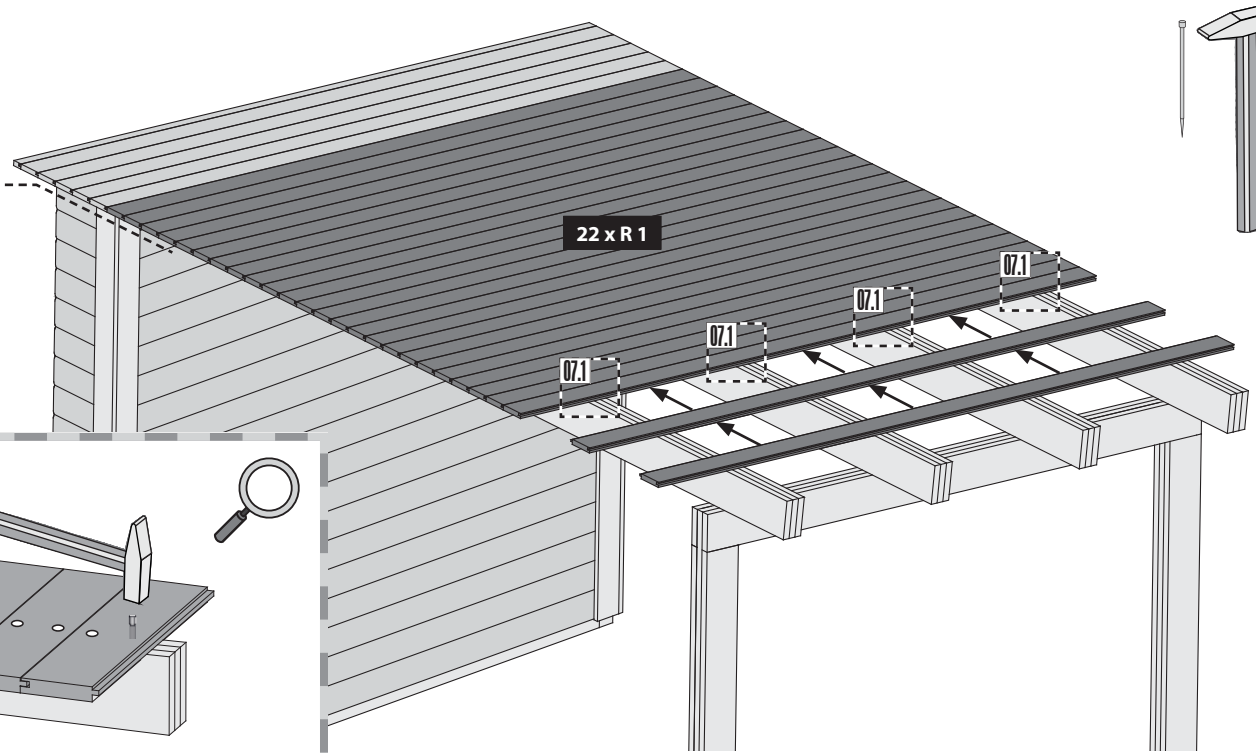

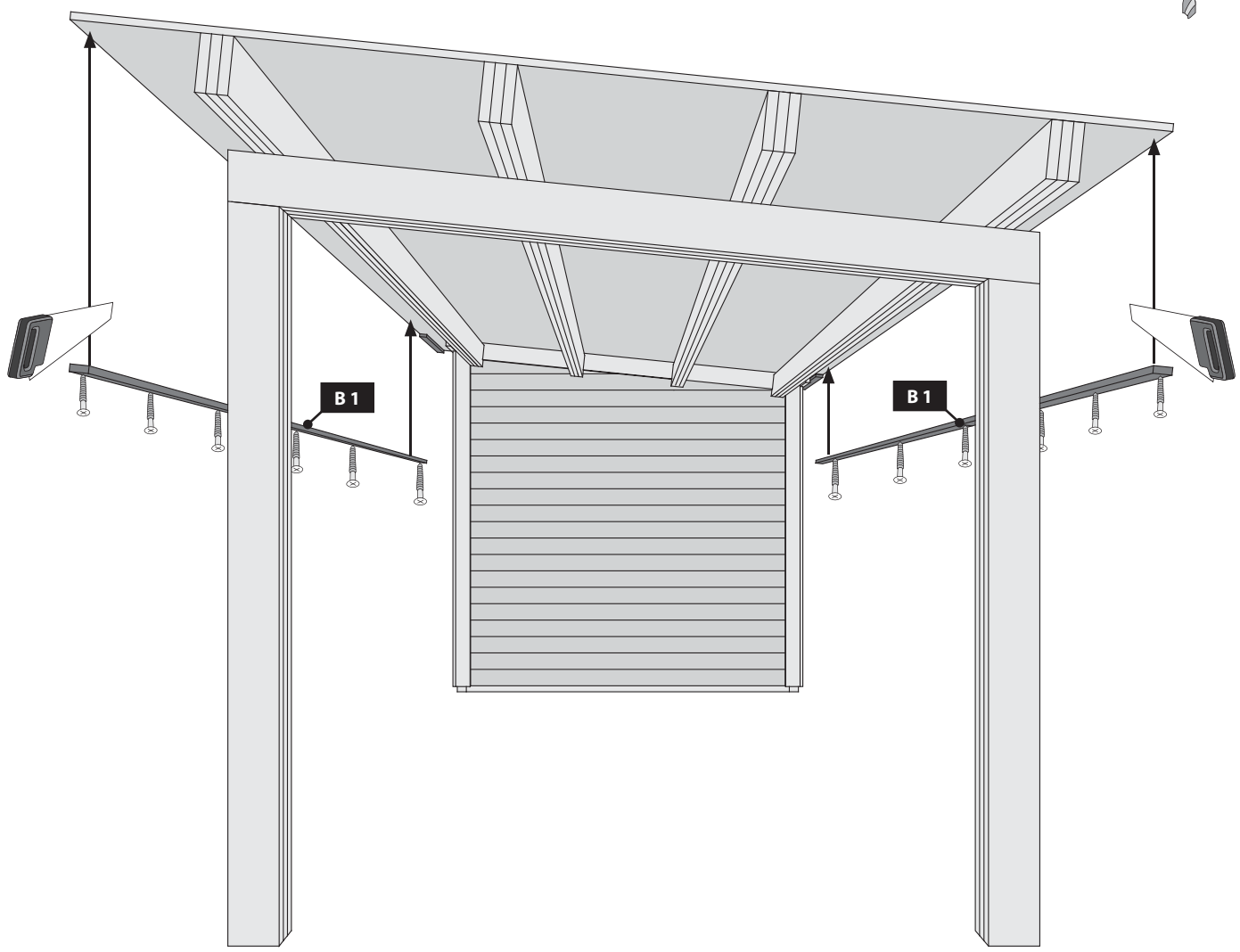
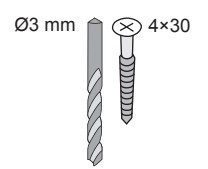
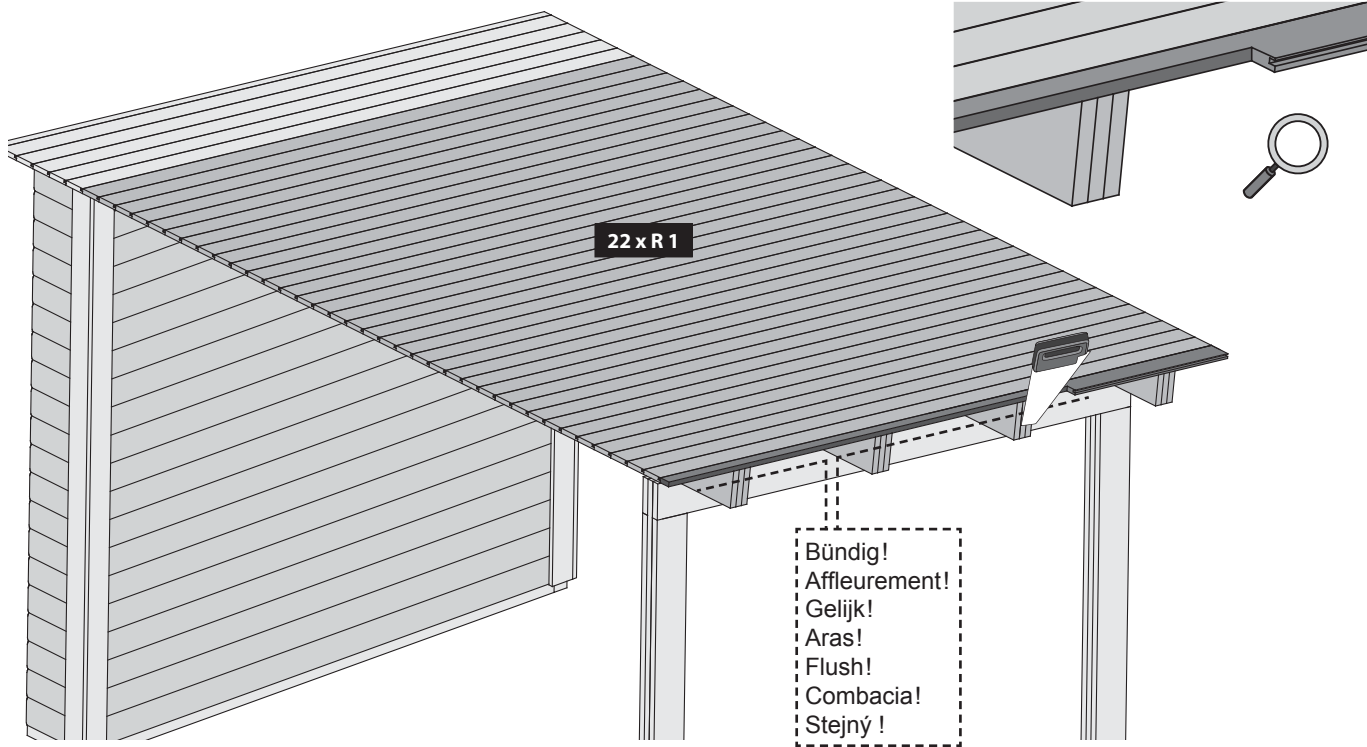



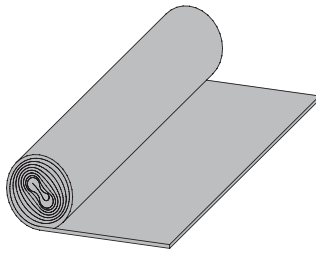
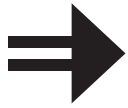

10

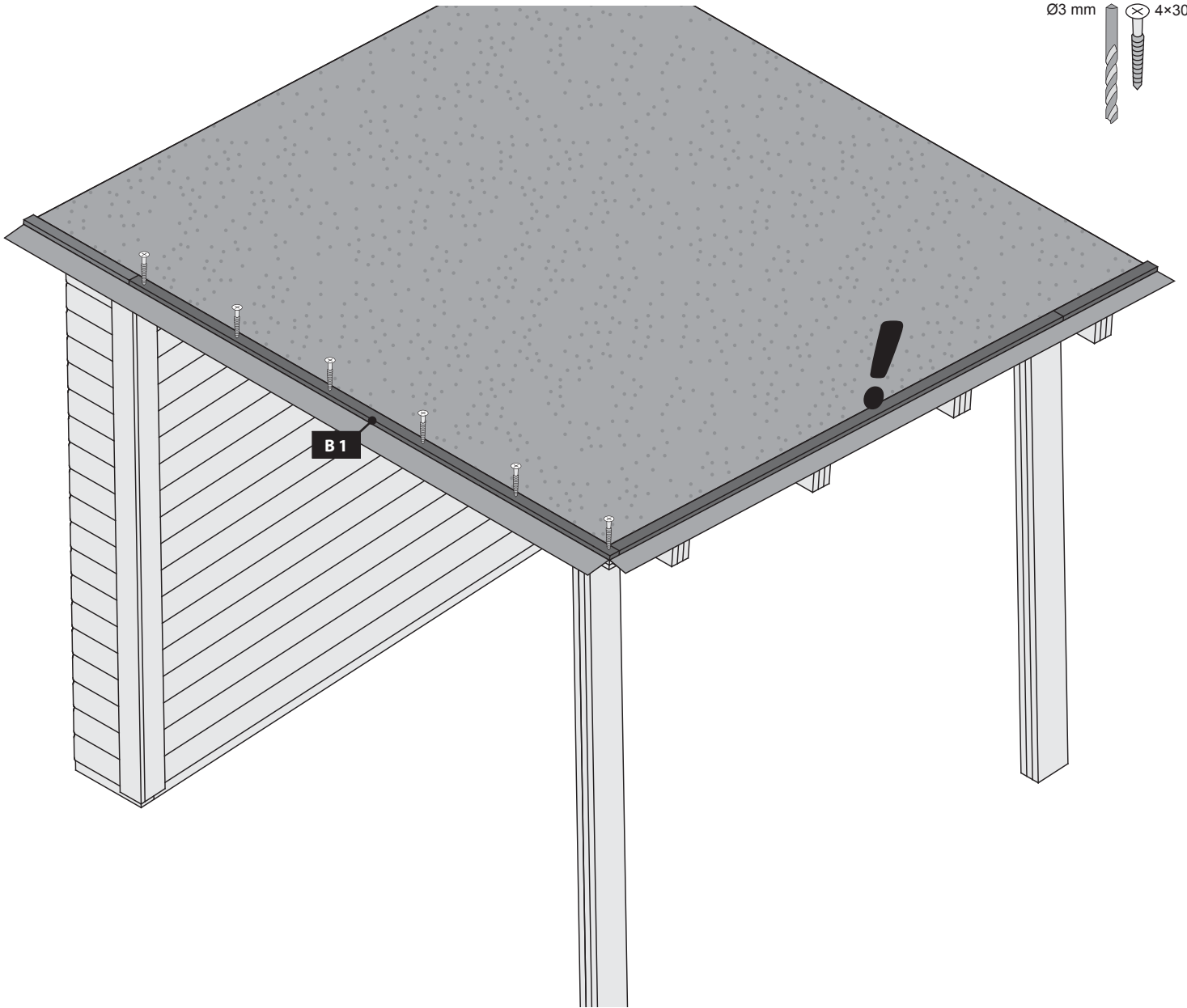
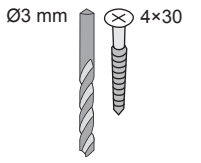

**!** 42

**79768** 14.06.2017

- Aufbauanleitung
- notice de montage
- Building Instructions
- montagehandleiding
- instrucciones de construcción
- Istruzioni per il montaggio
- Montáskönyv
- Service-Hotline +49 421 38693 33

**!** 42

**80563** 13.06.2017

- Aufbauanleitung
- notice de montage
- Building Instructions
- montagehandleiding
- instrucciones de construcción
- Istruzioni per il montaggio
- Montáskönyv
- Service-Hotline +49 421 38693 33

**!** 36

**80564** 27.07.2017

- Aufbauanleitung
- notice de montage
- Building Instructions
- montagehandleiding
- instrucciones de construcción
- Istruzioni per il montaggio
- Montáskönyv
- Service-Hotline +49 421 38693 33

**!** 38

**80568 80987** 14.07.2017

- Aufbauanleitung
- notice de montage
- Building Instructions
- montagehandleiding
- instrucciones de construcción
- Istruzioni per il montaggio
- Montáskönyv
- Service-Hotline +49 421 38693 33



ID 68589

- Für die dauerhafte Eindeckung empfehlen wir die selbstklebende Bitumendachbahn aus unserem Sortiment
- For permanent covering, we recommend self-adhesive bitumen roofing sheet from our range
- Pour revêtement permanent, nous vous recommandons de bitume auto-adhésif tôle de toiture de notre gamme
- Voor permanente bedekking, raden wij zelfklevende bitumen dakbaan uit ons assortiment
- Para cobertura permanente, recomendamos betún autoadhesivas Perfil de cubierta de nuestra gama
- Per copertura permanente, si consiglia di bitume autoadesive Lastra per coperture della nostra gamma
- Pro trvalé krytinou, doporučujeme samolepicí asfaltové střešní krytiny z našeho sortimentu

11

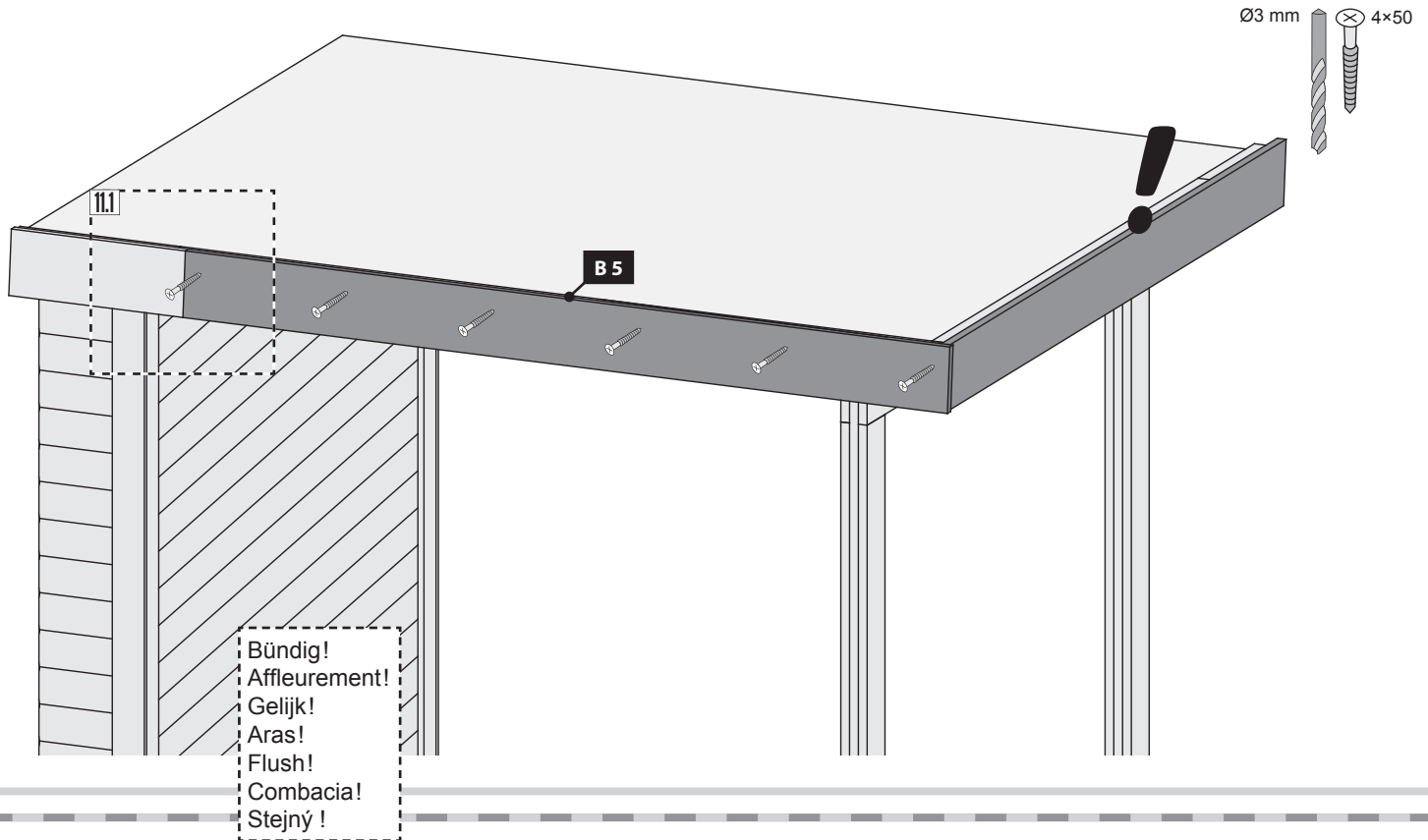

11.1

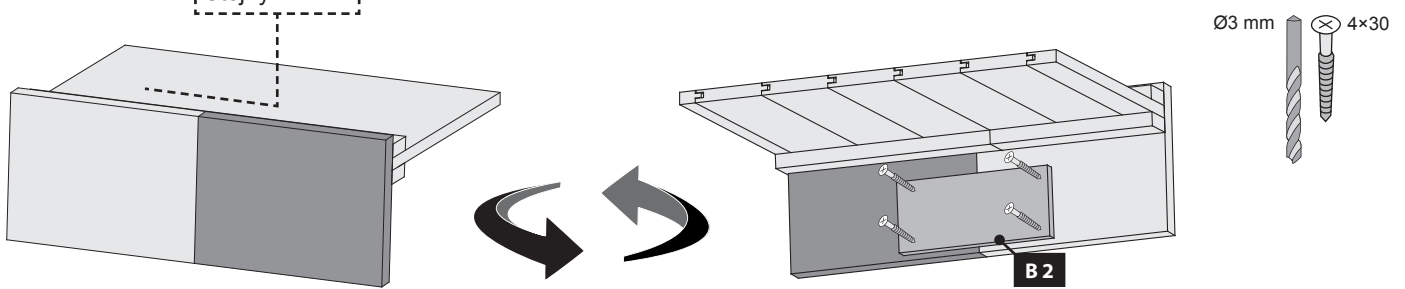

**!** 44

**79768** 14.06.2017

- Aufbauanleitung
- Notice de montage
- Building Instructions
- Montagehandleiding
- Instrucciones de construcción
- Istruzioni per il montaggio
- Montážní návod
- Service-Hotline: +49 421 38693 33

**!** 44

**80563** 14.06.2017

- Aufbauanleitung
- Notice de montage
- Building Instructions
- Montagehandleiding
- Instrucciones de construcción
- Istruzioni per il montaggio
- Montážní návod
- Service-Hotline: +49 421 38693 33

**!** 37

**80564** 27.07.2017

- Aufbauanleitung
- Notice de montage
- Building Instructions
- Montagehandleiding
- Instrucciones de construcción
- Istruzioni per il montaggio
- Montážní návod
- Service-Hotline: +49 421 38693 33

**!** 39

**80568 80987** 16.07.2017

- Aufbauanleitung
- Notice de montage
- Building Instructions
- Montagehandleiding
- Instrucciones de construcción
- Istruzioni per il montaggio
- Montážní návod
- Service-Hotline: +49 421 38693 33